

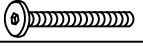

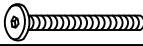
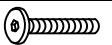

ASSEMBLY INSTRUCTIONS

MODEL# : F2636

KEEP THIS DOCUMENT FOR REFERENCE IN CASE PARTS ARE NEEDED
DO NOT TIGHTEN SCREWS UNTIL COMPLETELY ASSEMBLED !

No.	DESCRIPTION	Q'TY FOR 5PCS
A	TABLE TOP	1pc
B	TABLE LEG	4pcs
C	CHAIR BACK	4pcs
D	CHAIR SEAT	4pcs
E	CHAIR FRONT LEFT LEG	4pcs
F	CHAIR FRONT RIGHT LEG	4pcs
G	CHAIR LEFT STRETCHER	4pcs
H	CHAIR RIGHT STRETCHER	4pcs
I	CHAIR FRONT STRETCHER	4pcs

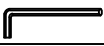
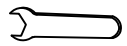
No.	DESCRIPTION	Q'TY FOR 5PCS
1	BOLT(5/16"x2-3/4") 	8pcs
2	BOLT(5/16"x3-1/8") 	16pcs
3	BOLT(5/16"x1-1/2") 	12pcs
4	NUT (5/16"x6mm) 	16pcs
5	SPRING WASHER(5/16") 	52pcs
6	METAL WASHER(5/16") 	52pcs
7	WOOD SCREW (M4x38mm) 	24pcs
8	ALLEN KEY 	1pc
9	KEY WRENCH 	1pc

STEP 1

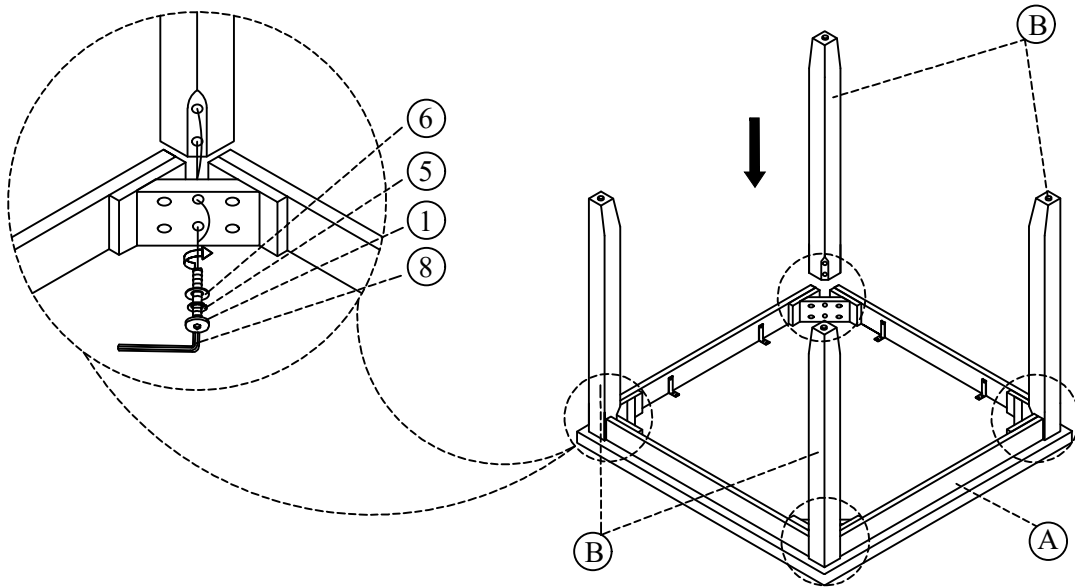

STEP 2

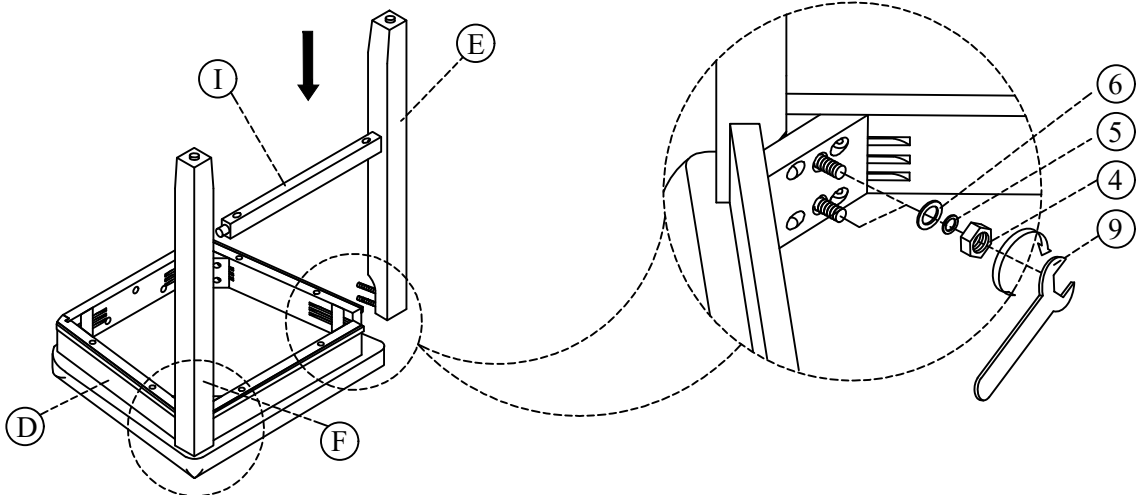

ASSEMBLY INSTRUCTIONS

MODEL# : F2636

KEEP THIS DOCUMENT FOR REFERENCE IN CASE PARTS ARE NEEDED
DO NOT TIGHTEN SCREWS UNTIL COMPLETELY ASSEMBLED !

STEP 3

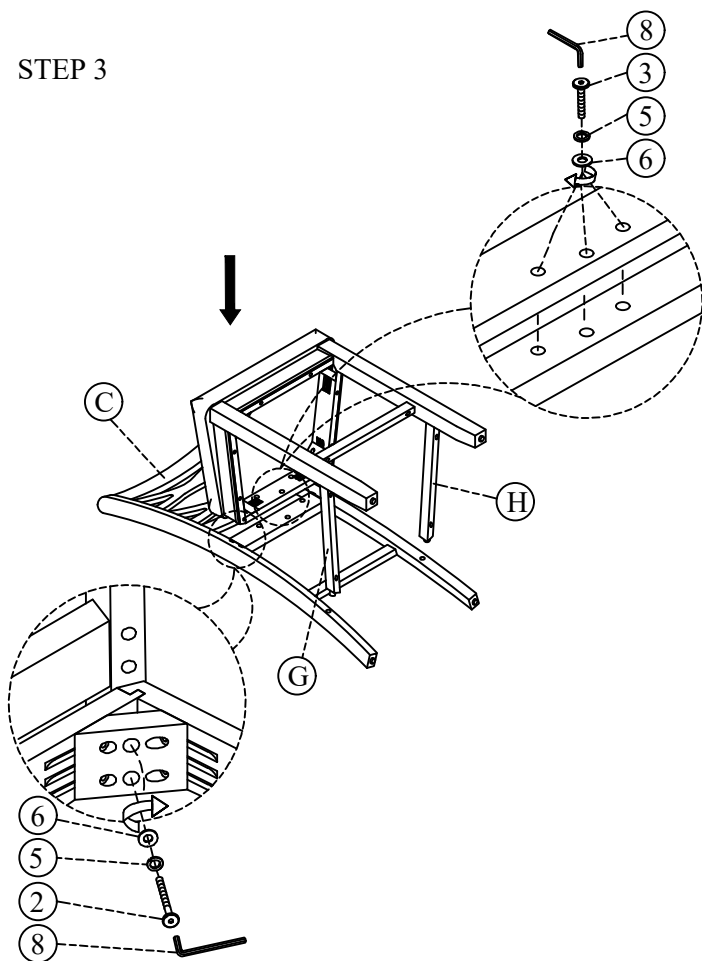

STEP 4

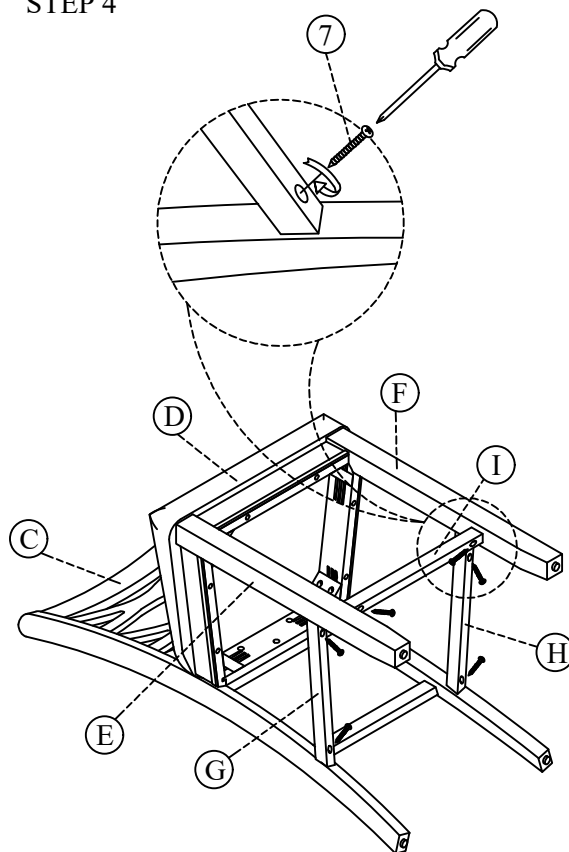

STEP 5

