





# ASSEMBLY INSTRUCTION

Description : Spindleback Windsor Chair

No	Part List	Qty
A	Chair Back	1
B	Legs Frame	2
C	Stretchers	1

No	Hardware List	Qty
D	JCBC Bolt M6 x 50 mm 	2
E	Barrel Nut 	2
F	JCBC Screw M7 x 35mm 	6
G	Allen Key 	1
H	Wood Button 	2

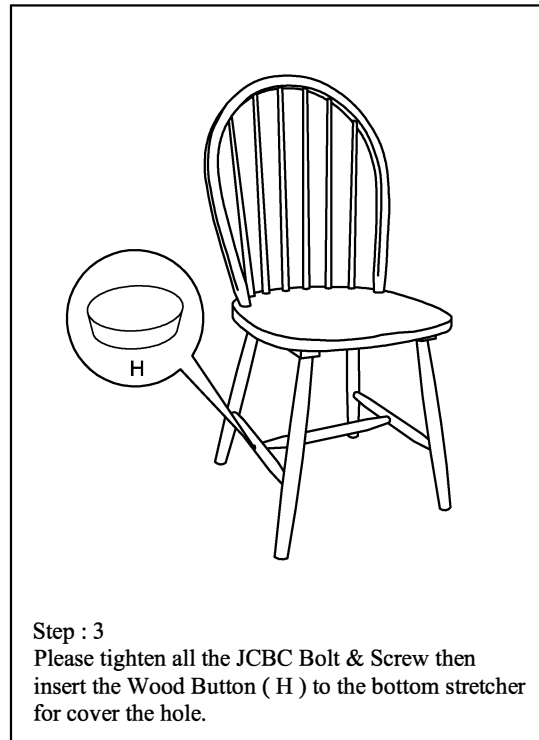
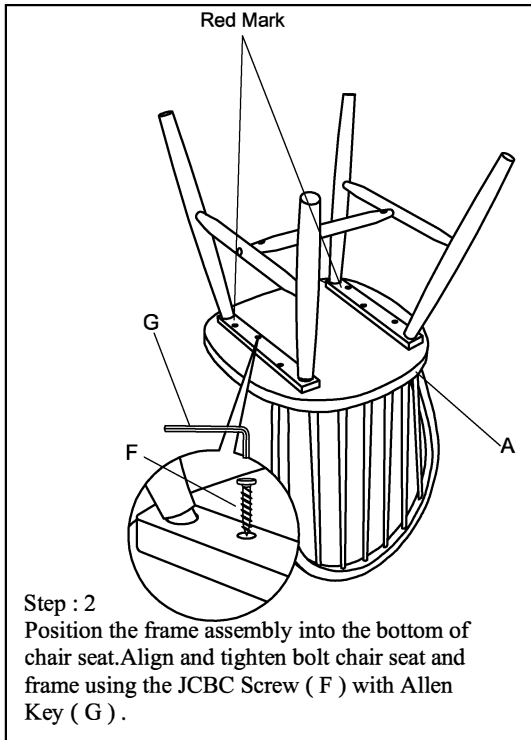
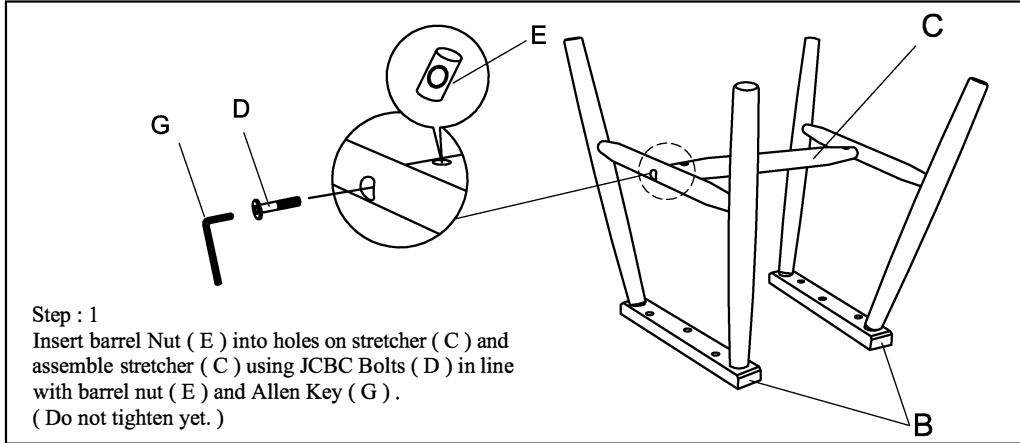

We appreciate your business!

- After a few days of initial assembly and chairs have acclimated to new environment retighten all hardware.
- For a permanent attachment, suggest that glue be used on stretcher ends



Important Notes