

ASSEMBLY INSTRUCTIONS

C-1162

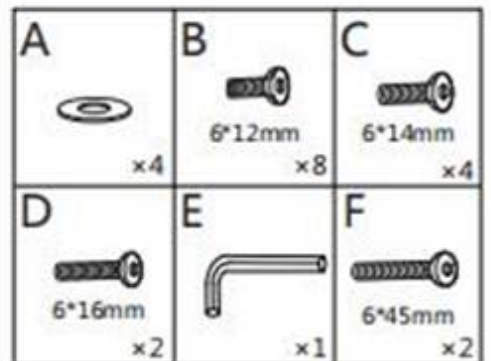

STEP 1 ③ and ④ are connected to ⑤ respectively, ⑥ is connected to ③ and ④, B is inserted into the corresponding hole and fastened with E.

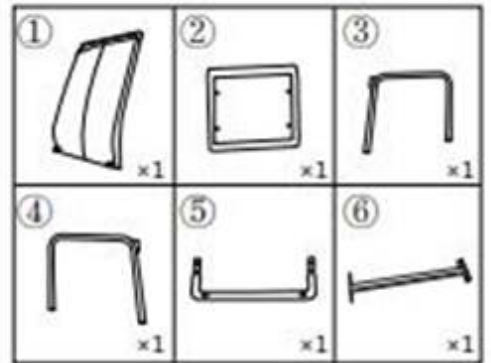
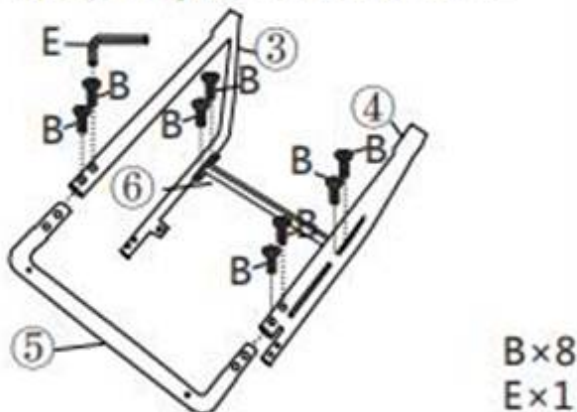

STEP 2 Connect ① to ③ and ④ respectively, insert C into the corresponding hole and tighten with E.

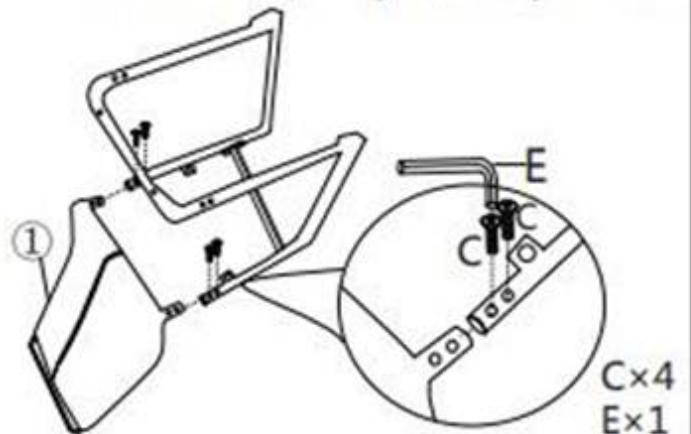

STEP 3 Connect ② to ③ and ④ respectively, fit D, A and F, A to the corresponding holes in turn and tighten D and F with E.

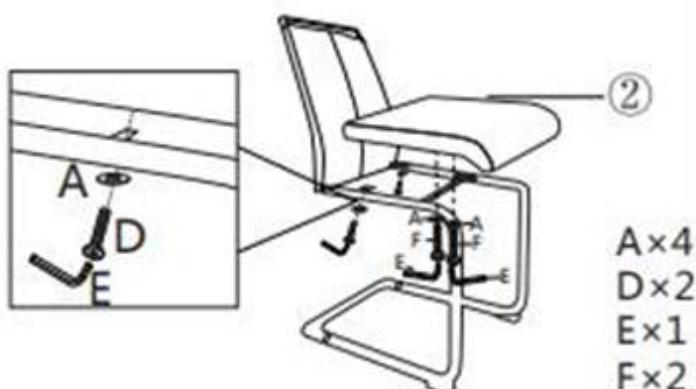

STEP 4 Installation complete

