

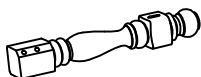

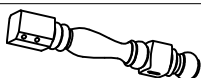



ASSEMBLY INSTRUCTIONS

Thank you for purchasing this quality product. Be sure to check all packing material carefully for small parts, which may have come loose inside the carton during shipment. Identify and count all parts and compare with the **HARDWARE LIST** below.

HARDWARE / PARTS LOCATION

D00511DB > Step 2, hardware 1 pc > Inside red pack with red tape > Placed at corner inside carton.

NO.	PARTS LIST		Q'TY
A	Top frame		1 Pc
B	Left Leg		2 Pcs
C	Right Leg		2 Pcs
D	Side Stretcher		2 Pcs
E	Center Stretcher		1 Pc

NO.	HARDWARE LIST		Q'TY
1		Bolt (1/4"x60mm)	8Pcs
2		Flat Washer (1/4"x3/4)	8Pcs
3		Spring Washer (1/4"x7/16)	8Pcs
4		Screw (5/32"x2")	6Pcs
5		Allen Key (5/32)	1Pc

Tool Needed: Phillips Screwdriver (not provided) 

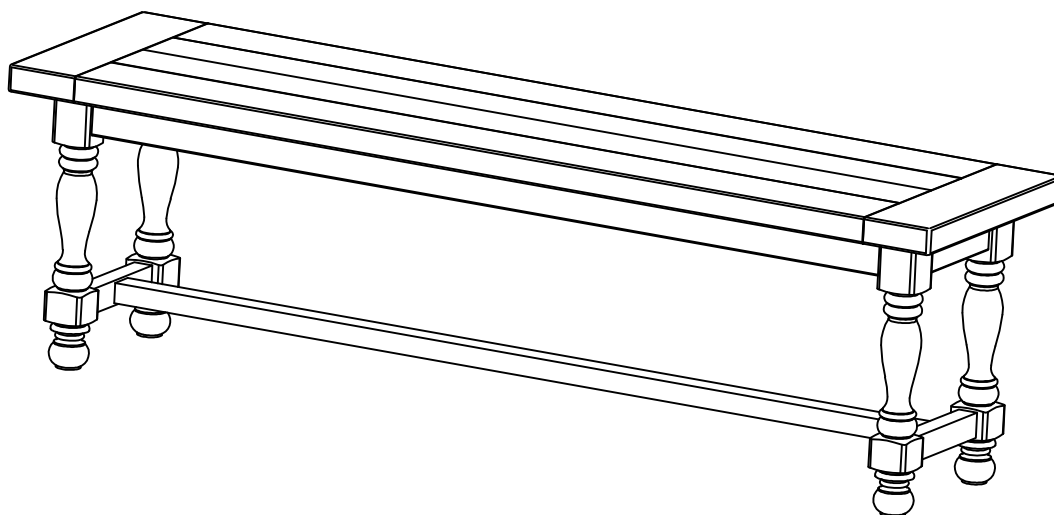

Note: Please **DO NOT** fully tighten all screws and bolts until the entire item is completely assembled

ASSEMBLY INSTRUCTIONS

STEP 1

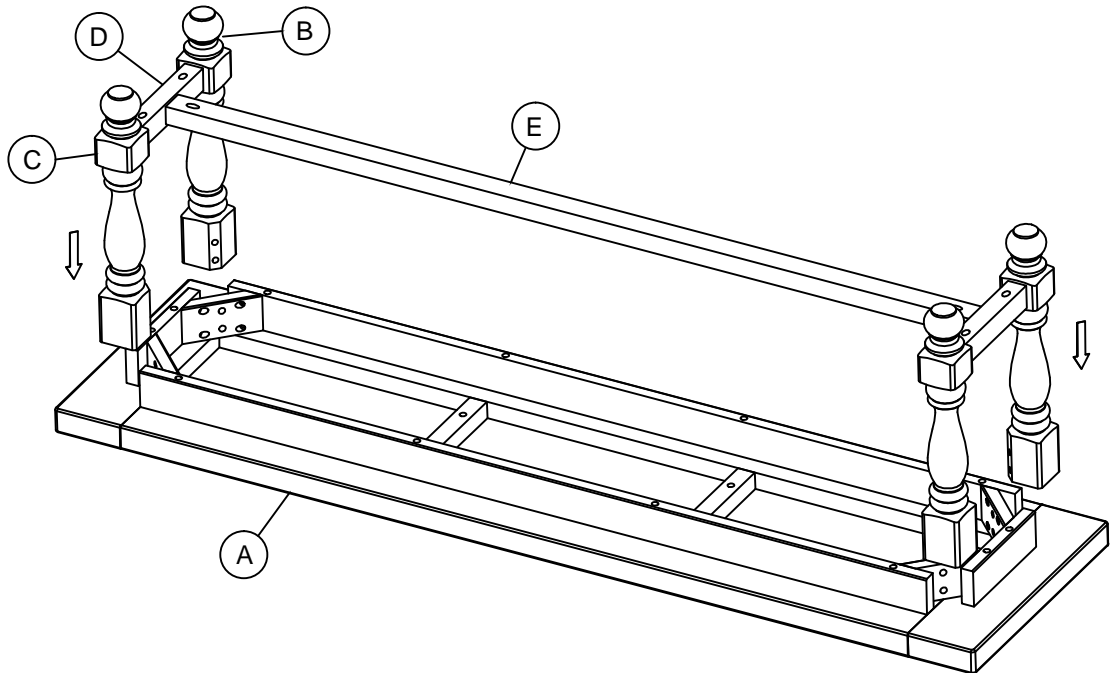

STEP 2

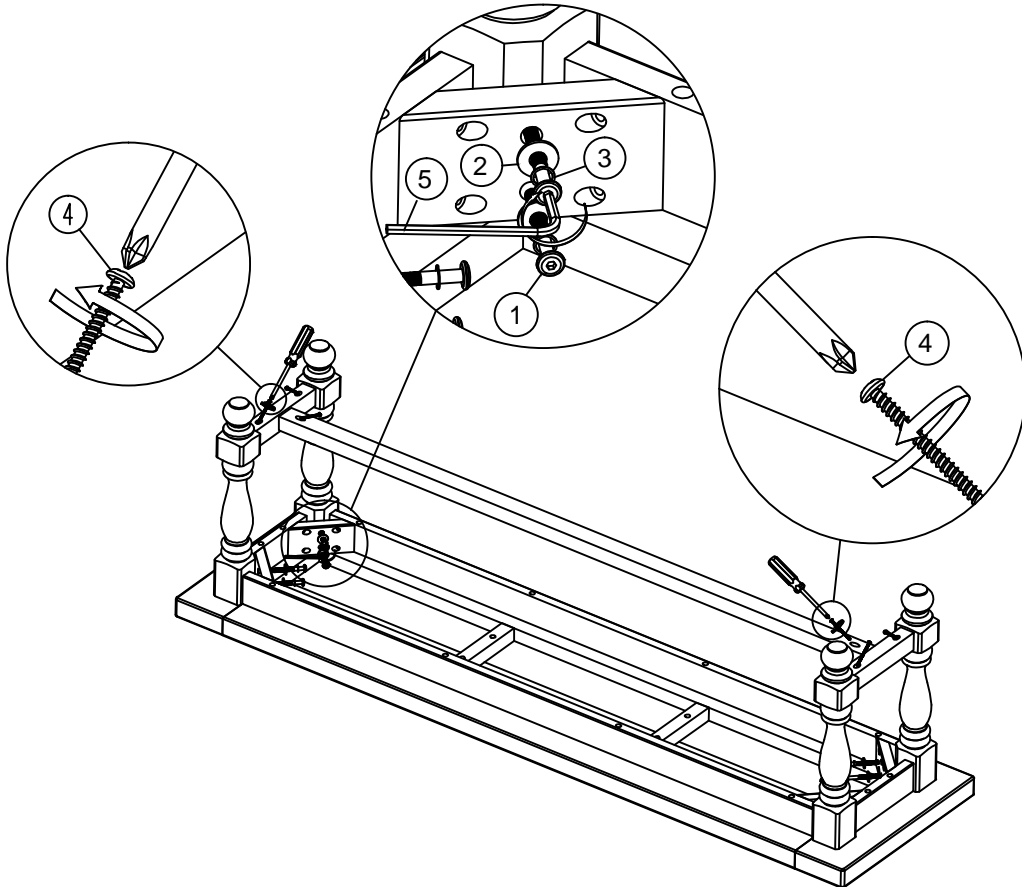

Note: Please DO NOT fully tighten all screws and bolts until the entire item is completely assembled

ASSEMBLY INSTRUCTIONS

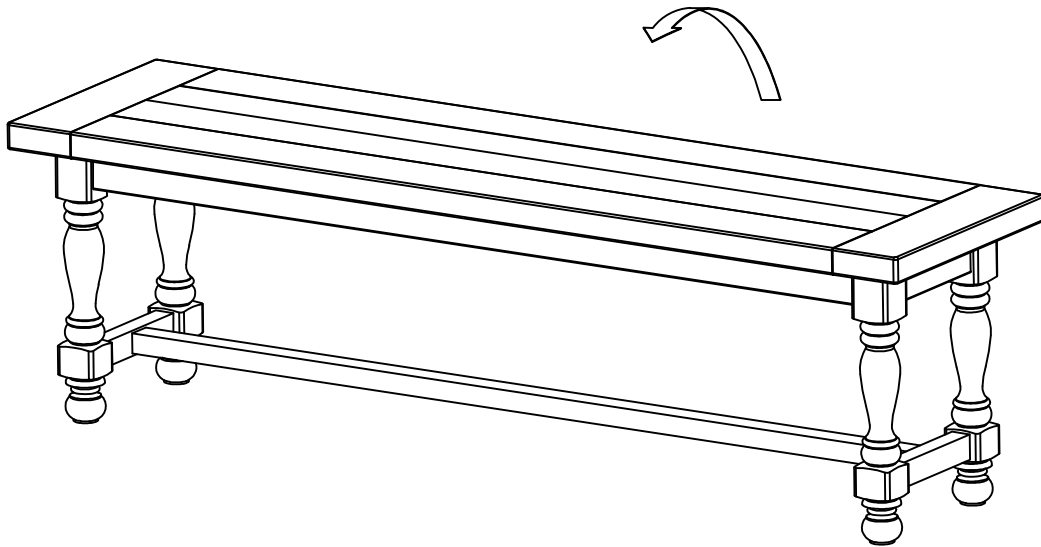

Note: Please DO NOT fully tighten all screws and bolts until the entire item is completely assembled

PAGE 3 OF 3