

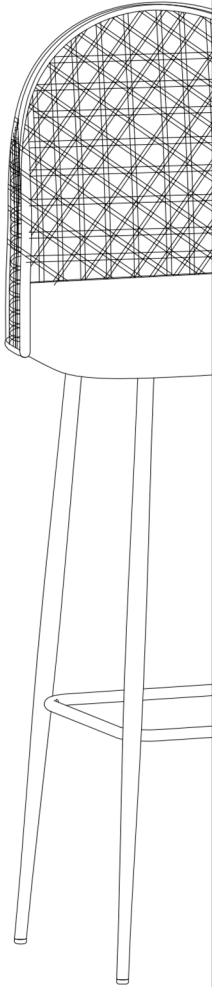

ITEM NO.Barst 05

WARRANTY



We strive to offer high quality product and we also try our best to satisfy each customer that order from us, no matter on products or services as needed. Each customer receives a record of their order, such as the order number or item receipt. For any items that are out of warranty period, you may still be able to purchase the replacement parts from our company if they are available.

For return, please check the return policy with the retailer or platforms you bought from. Appreciate your purchasing from us. Pop up your life by our furniture !

MAINTENANCE AND WARNING

Please read the manual thoroughly
before you start installing.

Please keep the product away from
sharp object.

Packaging and small parts may have
chocking hazard, please keep them away
from children and pets.

Please clean the product according to each
clean code, check the product description
for more information.

Please keep the product away from
fire.

If you have any other questions, please
contact us, we will be glad to help you out.

If the product is placed under direct
sunlight, the pattern or color might fade
away overtime.

Check the product periodically to make
sure everything is secured and tightened.

Always use proper tools for installation.

Do not jump on the product.

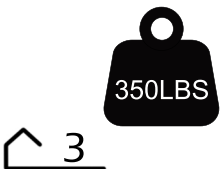

Around 35 min

PRODUCT DESCRIPTION

Ergonomic Comfort: The low-back design offers superior lumbar support, perfect for extended periods of sitting.

Natural Aesthetic: Wicker backrest adds a unique, textured look to the stools, blending seamlessly with modern or rustic décor.

Durable Fabric: The chenille seat is soft to the touch, providing lasting comfort and easy maintenance.

Sturdy Construction: Four solid metal legs ensure excellent stability, making this set perfect for everyday use.

Adjustable Footpins: Each leg features a rotating footpin, allowing you to level the stools on uneven surfaces, enhancing versatility.

EXPLODED VIEW

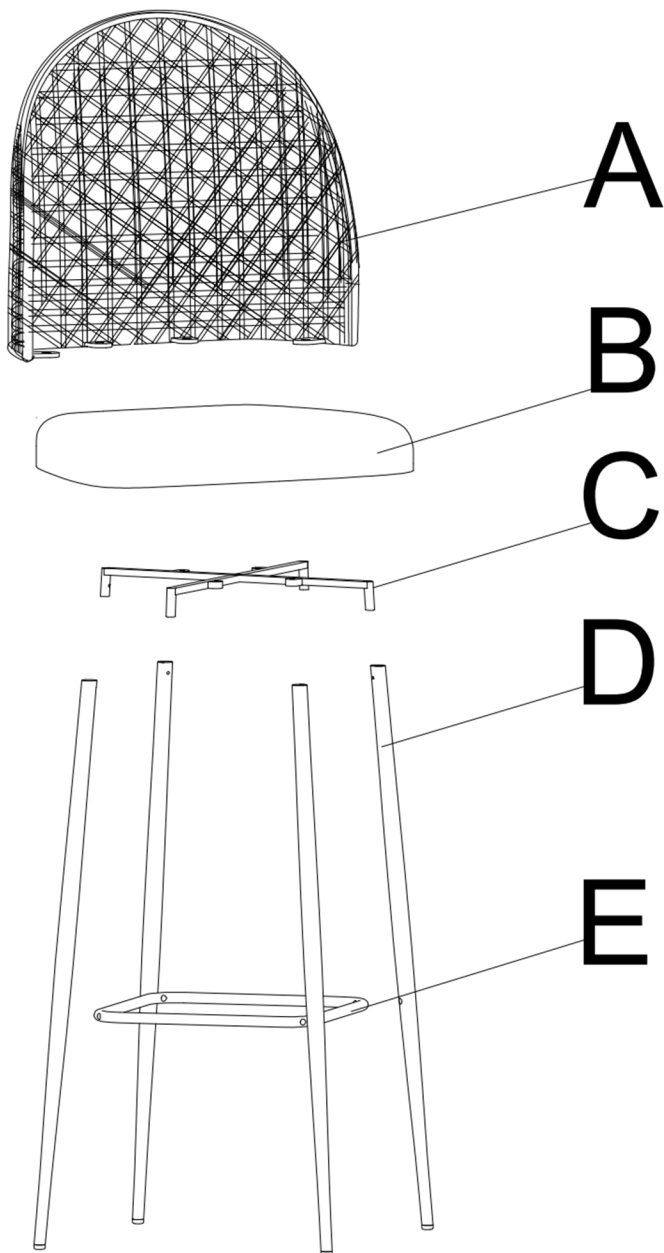

PARTS

A*1

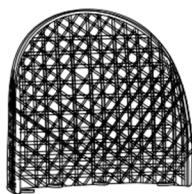

Backrest

B*1



Seat

C*1



Leg frame

D*4

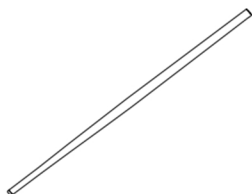

Legs

E*1



Footrest

HARDWARE

TOOL LIST

NOTE: Designated with (★) We provide additional spare parts in the hardware package

①*12



★ M6*15mm
Bolt

②*4



★ M6*30mm
Bolt

③*16



★ M6*15mm
Bolt

④*1



Allen key

⑤*4



★ Spring washer

Please make sure all hardware&packing material fitting the list. Especially some small accessories may be missing during transportation. Please contact us if you have any question.

step 1

Align the pre-drilled bolt holes from the Backrest to the back of the Seat as shown, then place one spring washer and one flat washer in order on each bolt, and use the Allen Wrench provided to fix the bolts.

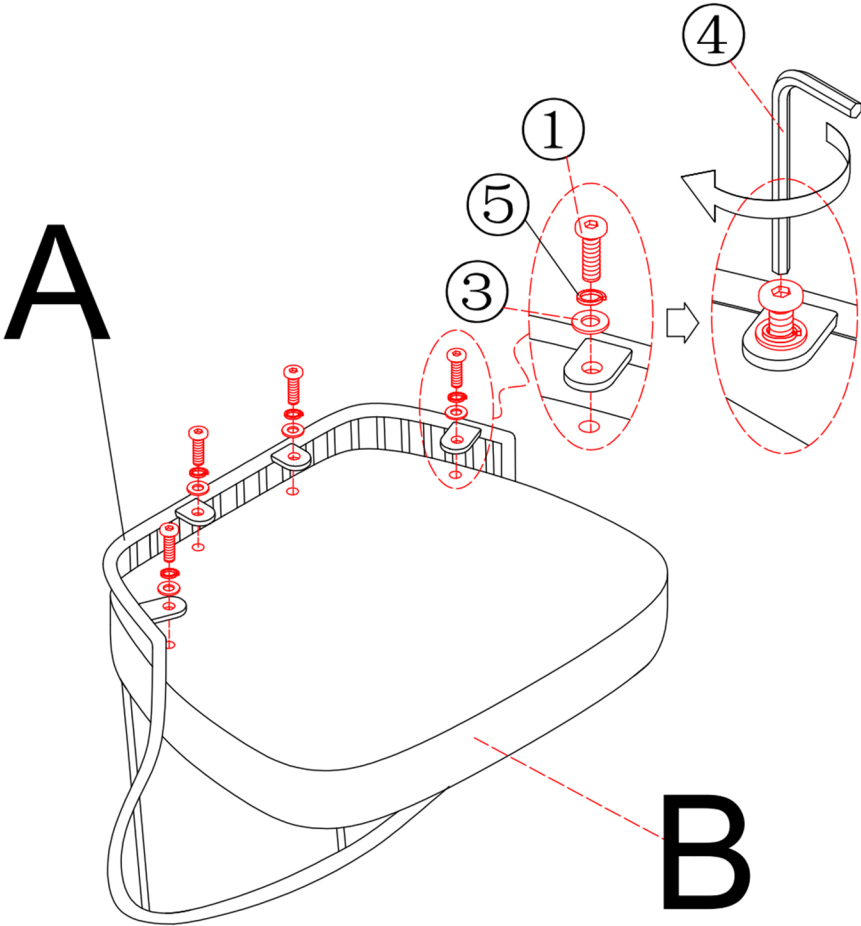

step 2

Install the leg frame to the bottom of the Seat as shown. Place one flat washer on each bolt first, then use the Allen Wrench provided to tighten all the bolts.

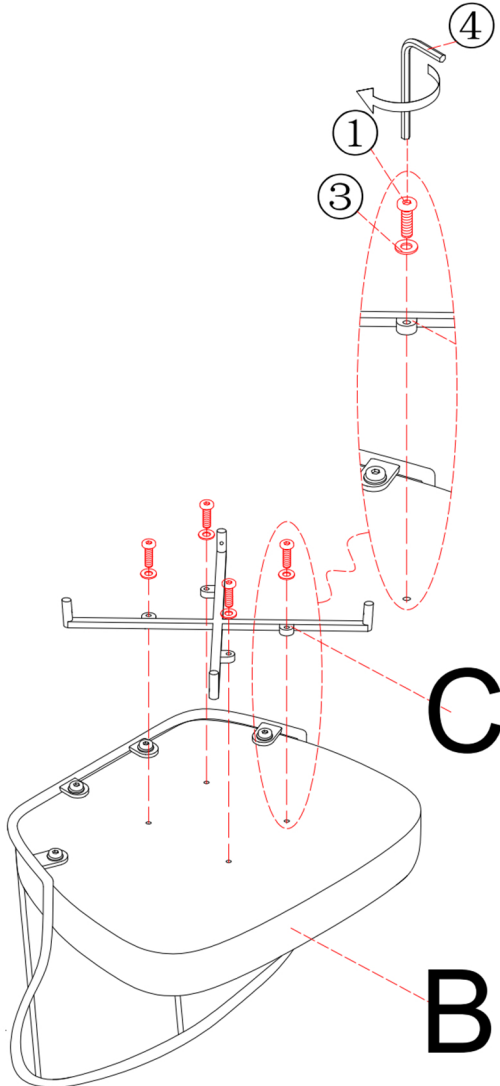

step 3

Insert each leg onto the leg frame as shown, make sure the pre-drilled bolt holes are aligned with the holes on the frame.

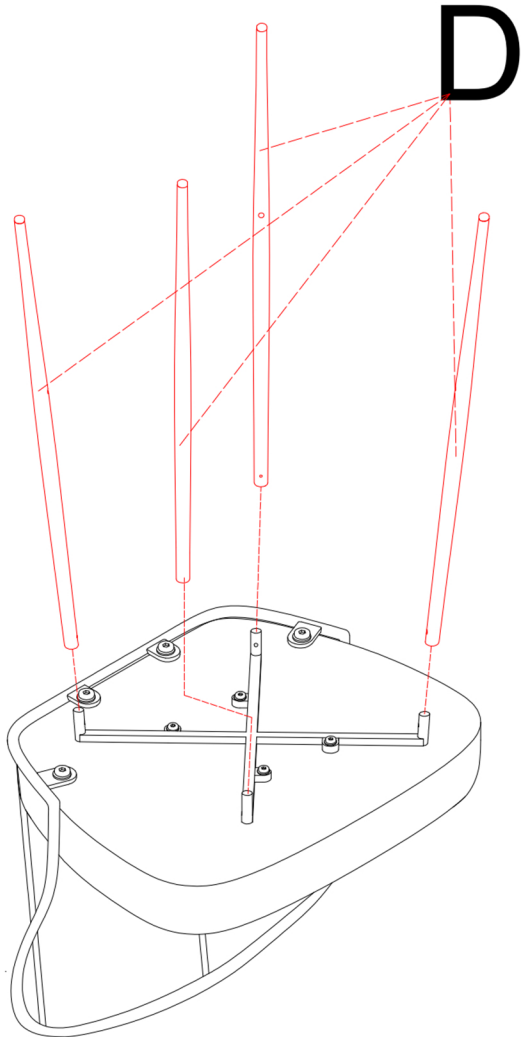

step 4

Use the Allen Wrench provided to tighten the bolts and washer on each leg in order to fix the legs.

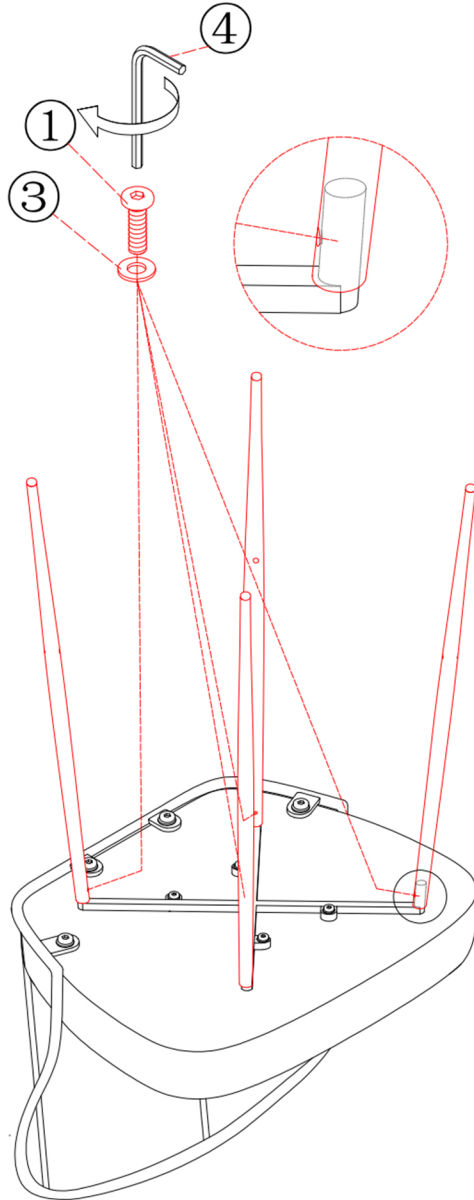

step 5

Install the Footrest to the legs as shown, use the Allen Wrench to tighten one bolt and washer to each leg, make sure the pre-drilled holes on both parts are correctly aligned.

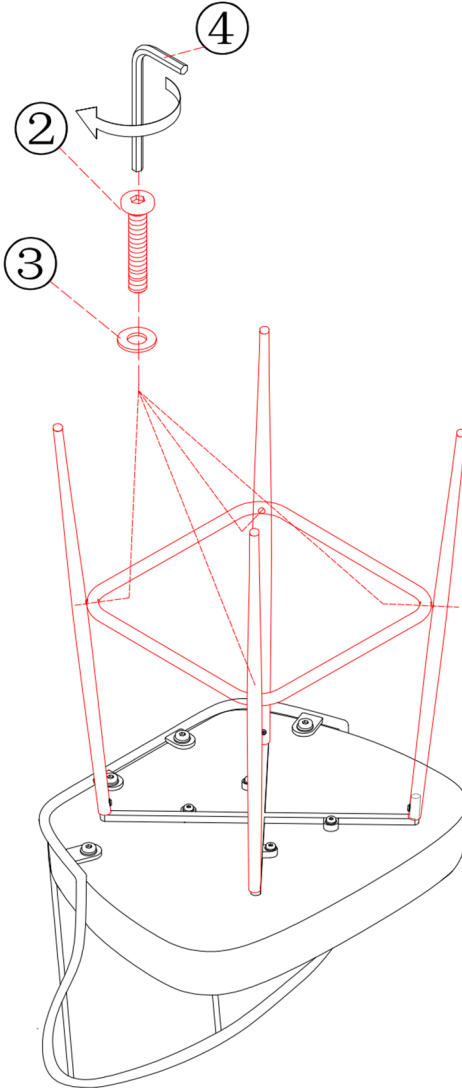

step 6

Please note: the legs of the bar stool can be adjusted by twisting the leveler on the tip of the legs as shown, it can help you use this chair on ground that is not flat, please check before you use the chair.

