

ASSEMBLY INSTRUCTIONS

DINING TABLE

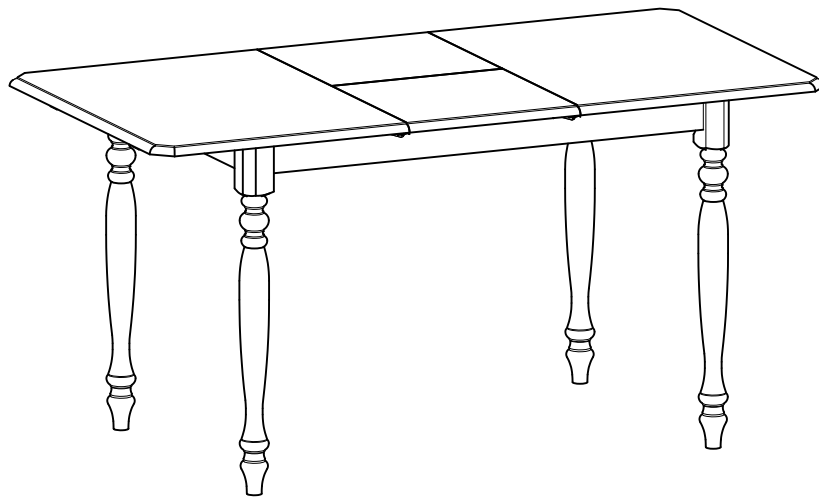

WF305187

IMPORTANT NOTE:

- PLACE ALL PARTS ON A CLEAN AND SMOOTH SURFACE SUCH AS A RUG OR CARPET TO AVOID THE PARTS FROM BEING SCRATCHED.
- BEFORE YOU BEGIN, KINDLY FOLLOW THE ASSEMBLY INSTRUCTIONS STEP BY STEP.
- DO NOT TIGHTEN ALL SCREWS AND BOLTS UNTIL THE TABLE IS FULLY SET-UP.

CARTON CONTENT:

WF305187 :

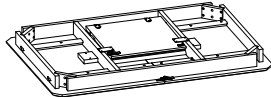
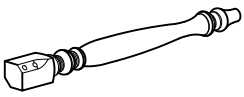

1 x 4

2 x 1

TABLE PART LISTS

NO.	DESCRIPTION	SKETCH	QTY
1	TABLE LEG		4 PCS
2	TABLE TOP		1 PC

TABLE HARDWARE LISTS

NO.	DESCRIPTION	SKETCH	QTY
A	HEX COMB 5/16 x 2 1/2"		8 PCS
B	SPRING WASHER 5/16"		8 PCS
C	FLAT WASHER 5/16"		8 PCS
D	SPANNER 1.28		1 PC

STEP 1

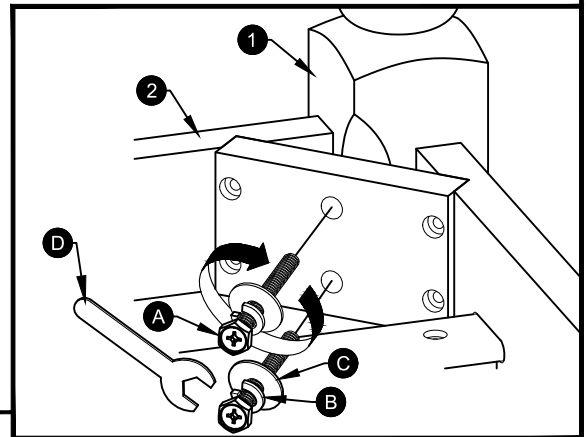
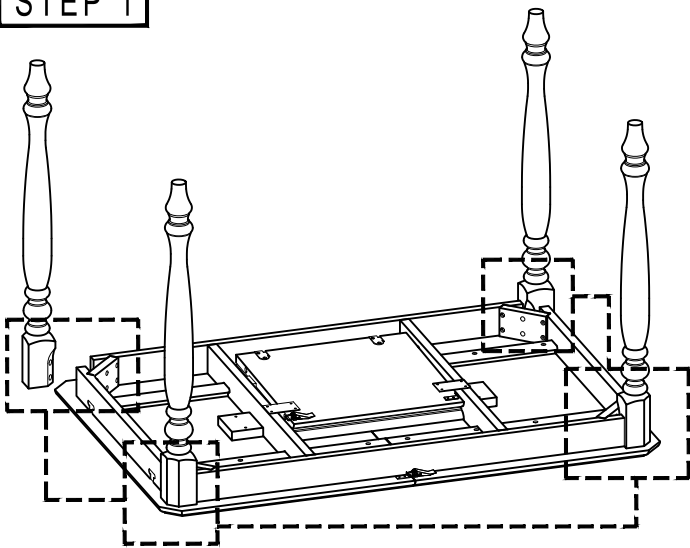

STEP 2

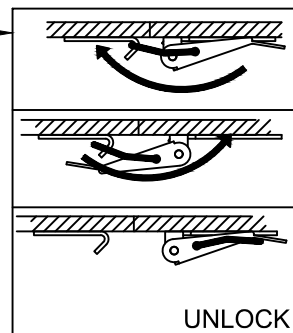
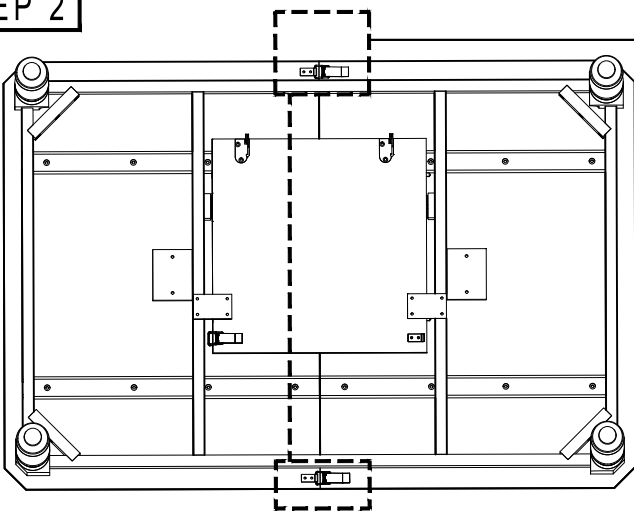

STEP 3

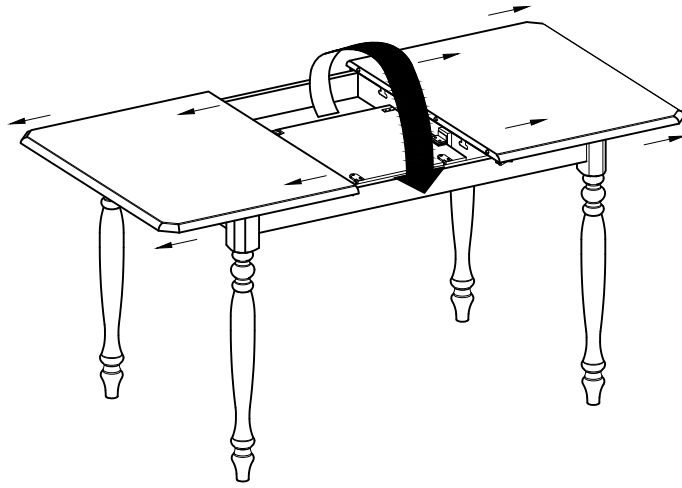

STEP 4

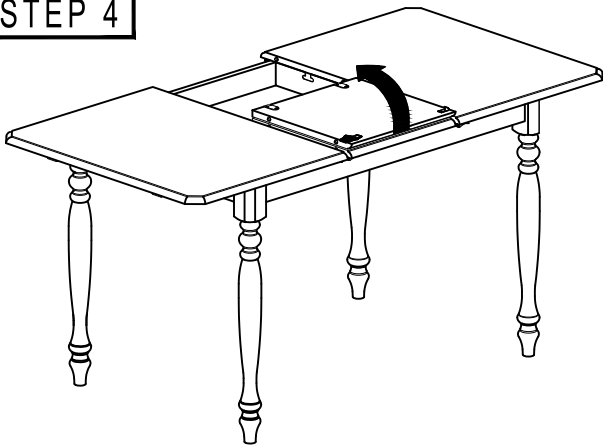

STEP 5



STEP 6

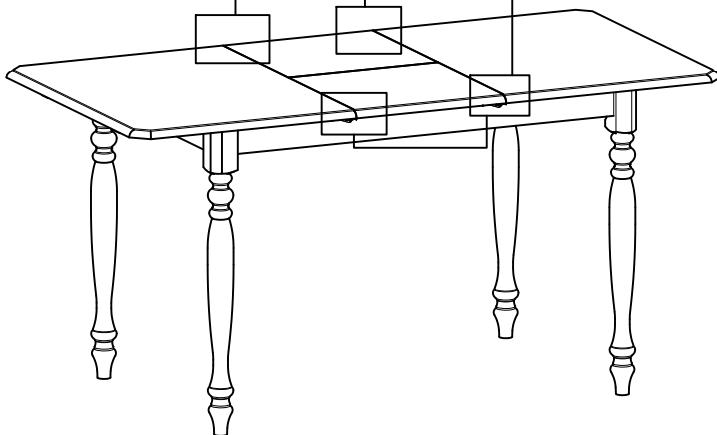
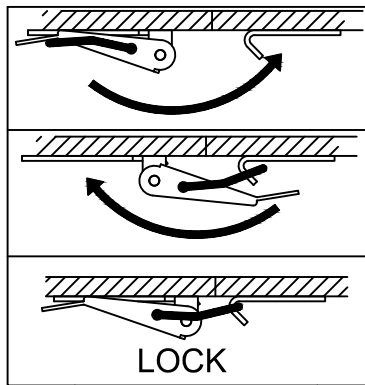

ASSEMBLY
COMPLETE !

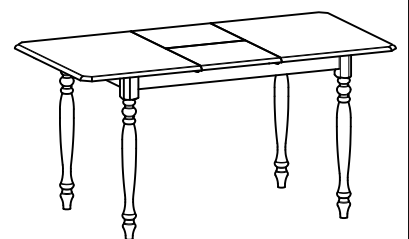

ASSEMBLY INSTRUCTIONS

DINING CHAIR

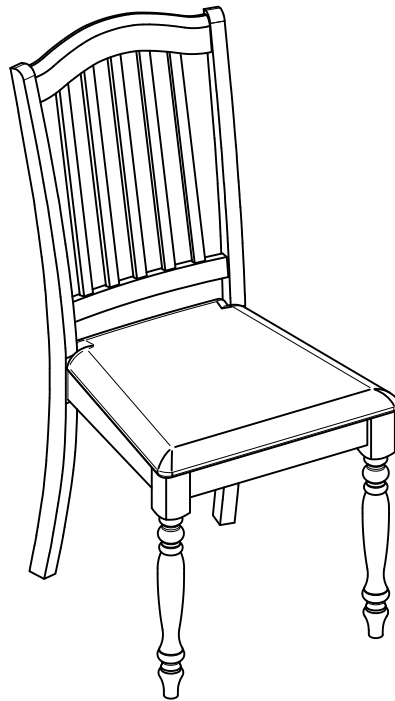

WF305190

IMPORTANT NOTE:

- PLACE ALL PARTS ON A CLEAN AND SMOOTH SURFACE SUCH AS A RUG OR CARPET TO AVOID THE PARTS FROM BEING SCRATCHED.
- BEFORE YOU BEGIN, KINDLY FOLLOW THE ASSEMBLY INSTRUCTIONS STEP BY STEP.
- DO NOT TIGHTEN ALL SCREWS AND BOLTS UNTIL THE CHAIR IS FULLY SET-UP.

CARTON CONTENT:

WF305190 :

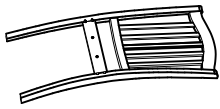

1 x 4

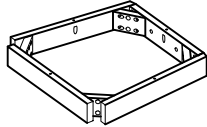

2 x 4

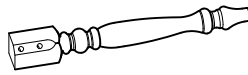

3 x 8

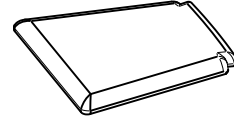

4 x 4

CHAIR PART LISTS

NO.	DESCRIPTION	SKETCH	QTY
1	BACK LEG		4 PCS
2	BOX SEAT		4 PCS
3	FRONT LEG		8 PCS
4	SEAT		4 PCS

CHAIR HARDWARE LISTS

NO.	DESCRIPTION	SKETCH	QTY
A	JCBC BOLT M6 x 35mm		8 PCS
B	JCBC BOLT M6 x 60mm		16 PCS
C	JCBC BOLT M6 x 80mm		16 PCS
D	SPRING WASHER 1/4"		40 PCS
E	FLAT WASHER 1/4"		40 PCS
F	ALLEN KEY M4		1 PC
G	C/B SCREW M4 x 30mm		16 PCS

STEP 1

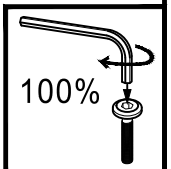
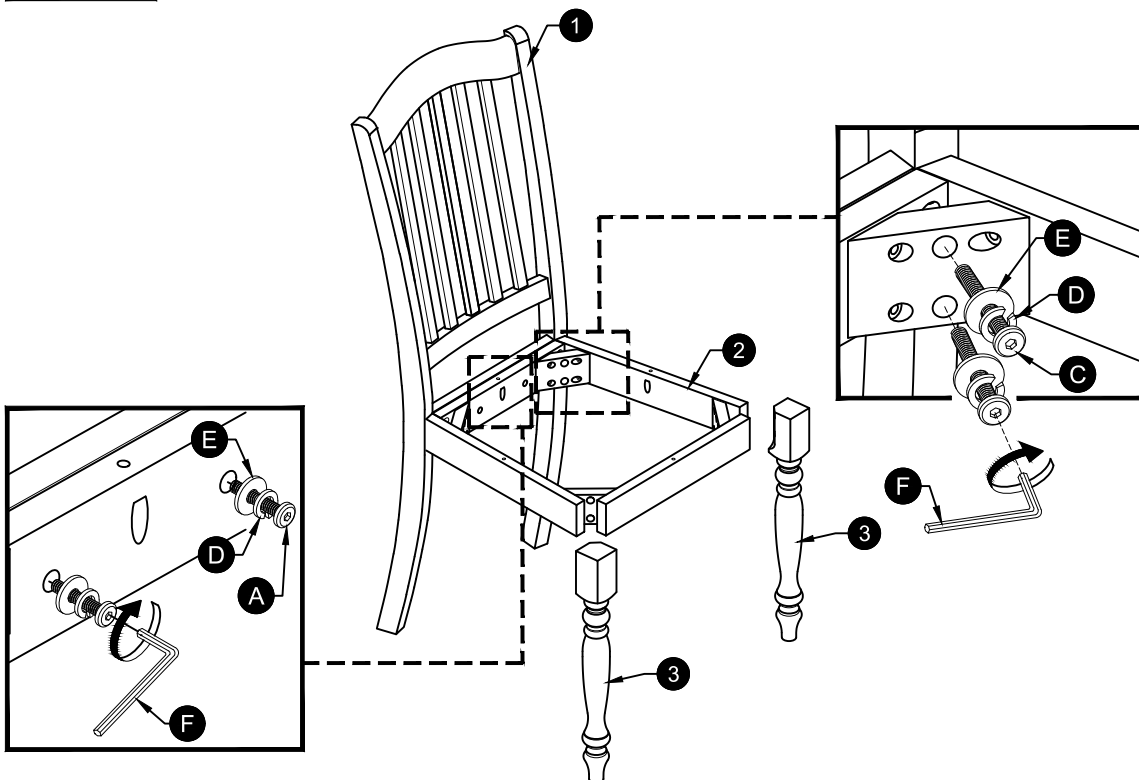

STEP 2

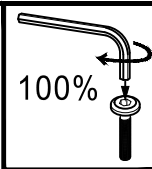
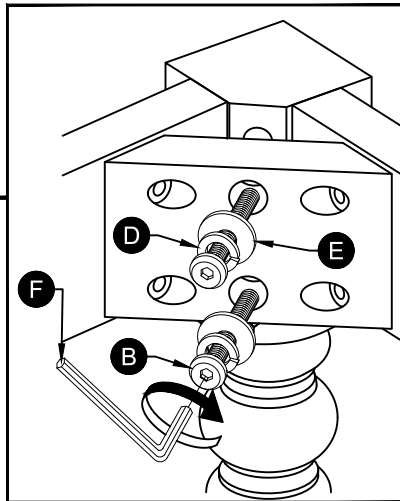
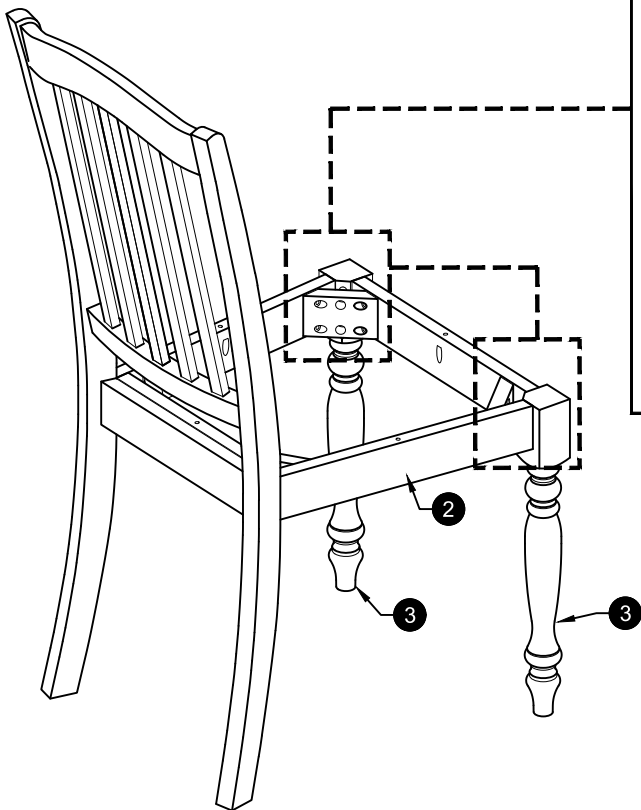

STEP 3

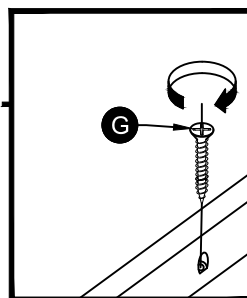
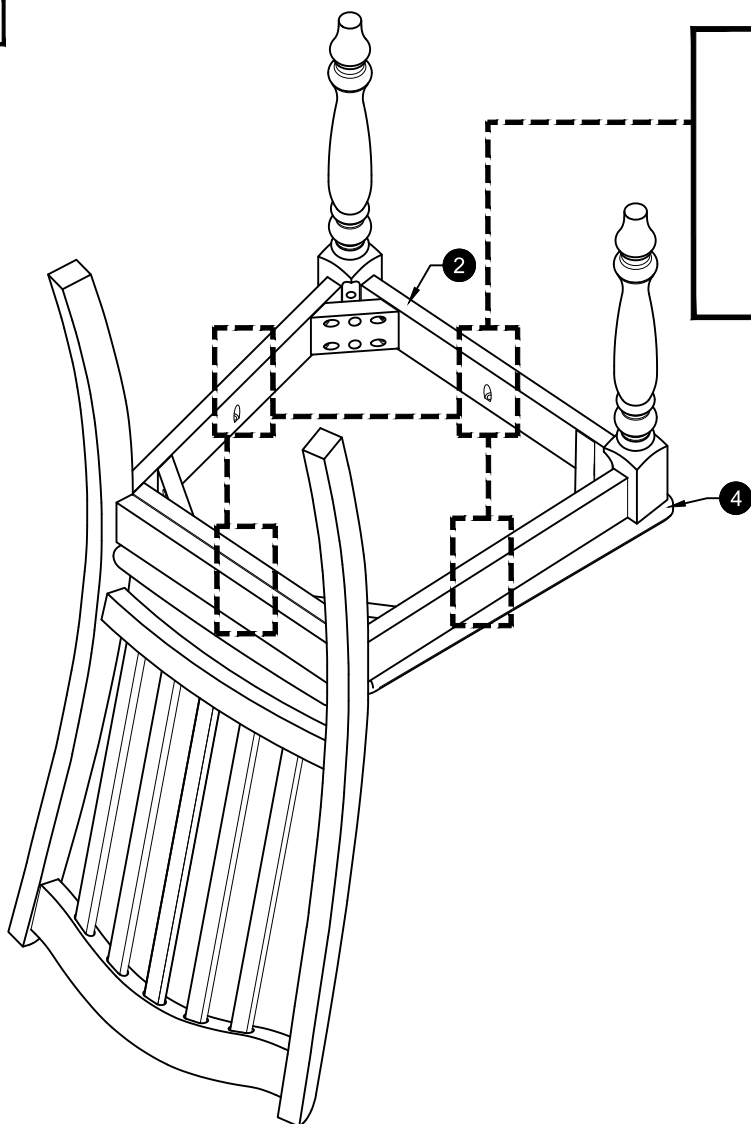

ASSEMBLY
COMPLETE !

