

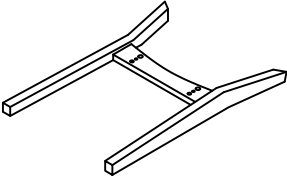

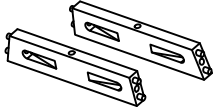

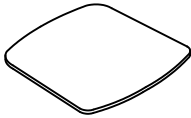

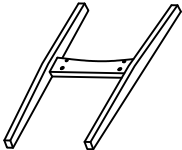
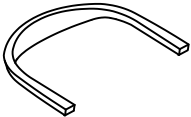

Product Assembly Instructions

DINING CHAIR

PART LIST

 <p>A : FRONT LEG x1</p>	 <p>B : RAIL (L & R) x2</p>	 <p>C : VENEER SEAT x1</p>
 <p>D : BACK LEG x1</p>	 <p>E : BACK VENEERS x1</p>	

HARDWARE LIST

 <p>F : JCBC SCREW M6 x 50MM x4</p>	 <p>G : JCBC SCREW M6 x 60MM x2</p>	 <p>H : SPRING WASHER 1/4" x6</p>
 <p>I : WOOD DOWEL DIA 8 x 30mm x8</p>	 <p>J : CSK SOCKET SCREW M6 x 25MM x4</p>	 <p>K : METAL PLATE x4</p>
 <p>L : M4 ALLEN KEY (BALL SHAPE) LONG x1</p>	 <p>M : PAN HEAD SCREW M4 x 16MM x4</p>	

STEP 1

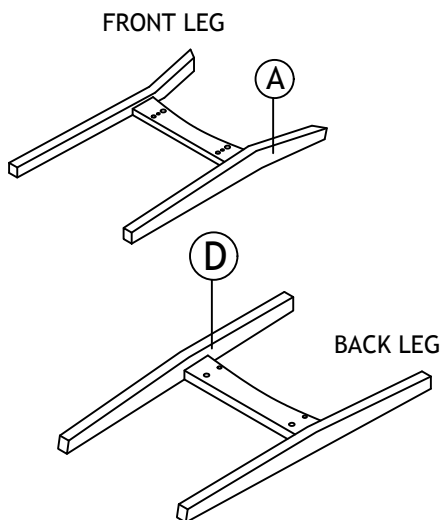

STEP 2

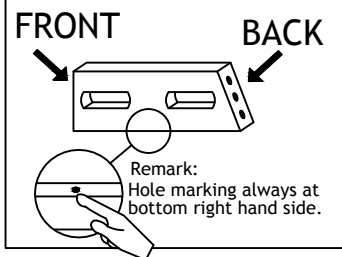
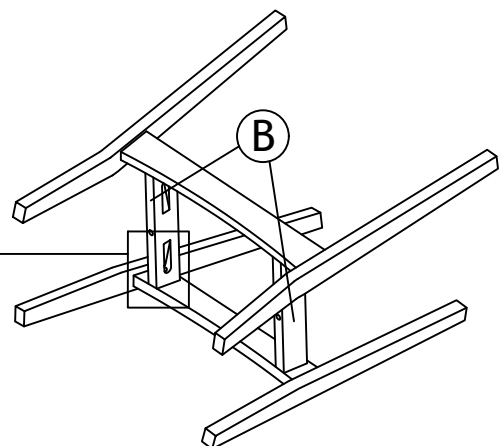
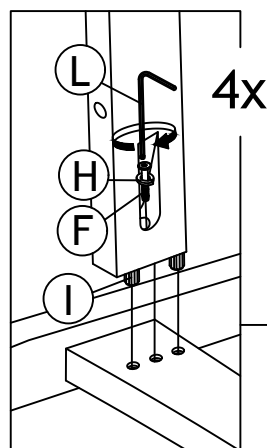

STEP 3

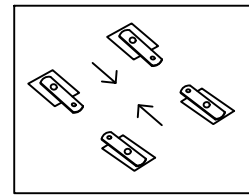
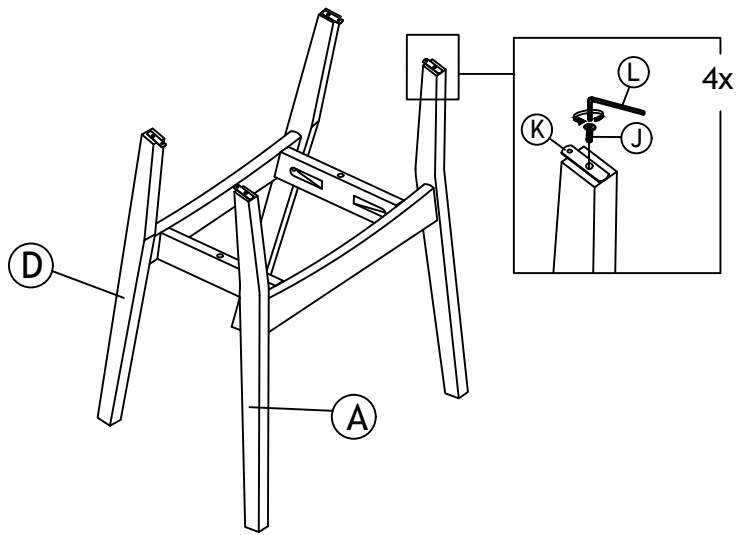

Remark:
When assembly, make sure
direction face to each other.

STEP 4

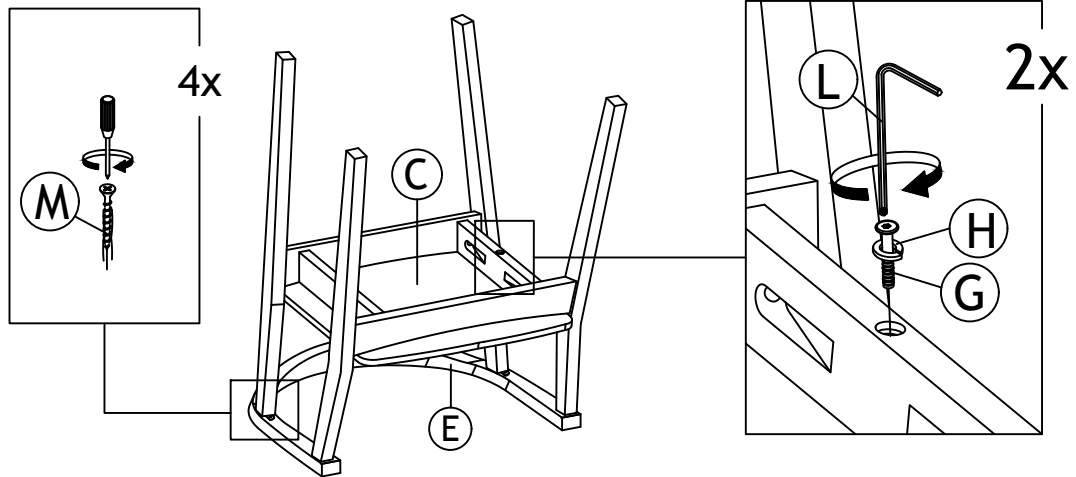

STEP 5

