













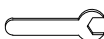

ASSEMBLY INSTRUCTIONS

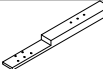
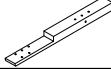
KING HEADBOARD-UPH
KING FOOTBOARD - STORAGE
QUEEN/KING STORAGE RAILS

Thank you for purchasing this quality product. Be sure to check all packing material carefully for small parts, which may have come loose inside the carton during shipment. Identify and count all parts and compare with the **HARDWARE LIST** below.

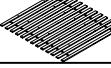
NO.	HARDWARE LIST		Q'TY
A		Ø5/16"X19X2mm Flat washer	12
B		Ø5/16"X13X1mm Spring washer	12
C		Ø5/16"X45mm Bolt	12
D		4mm Allen wrench	1
E		Ø5/16"X4-1/2" Bolt	8
F		Ø5/16" Half Moon Washer	8
G		Ø5/16" x 12mm Hex Nut	8
H		12mm Wrench	1
I		#8x1" Screw	26

NO.	PARTS LIST		Q'TY
1		Headboard	1
2		Headboard leg (left)	1
3		Headboard leg (right)	1
4		Bottom stretcher	1
5		Side rails	2
6		Storage footboard	1
7		Slat roll	13
8		Support leg	12

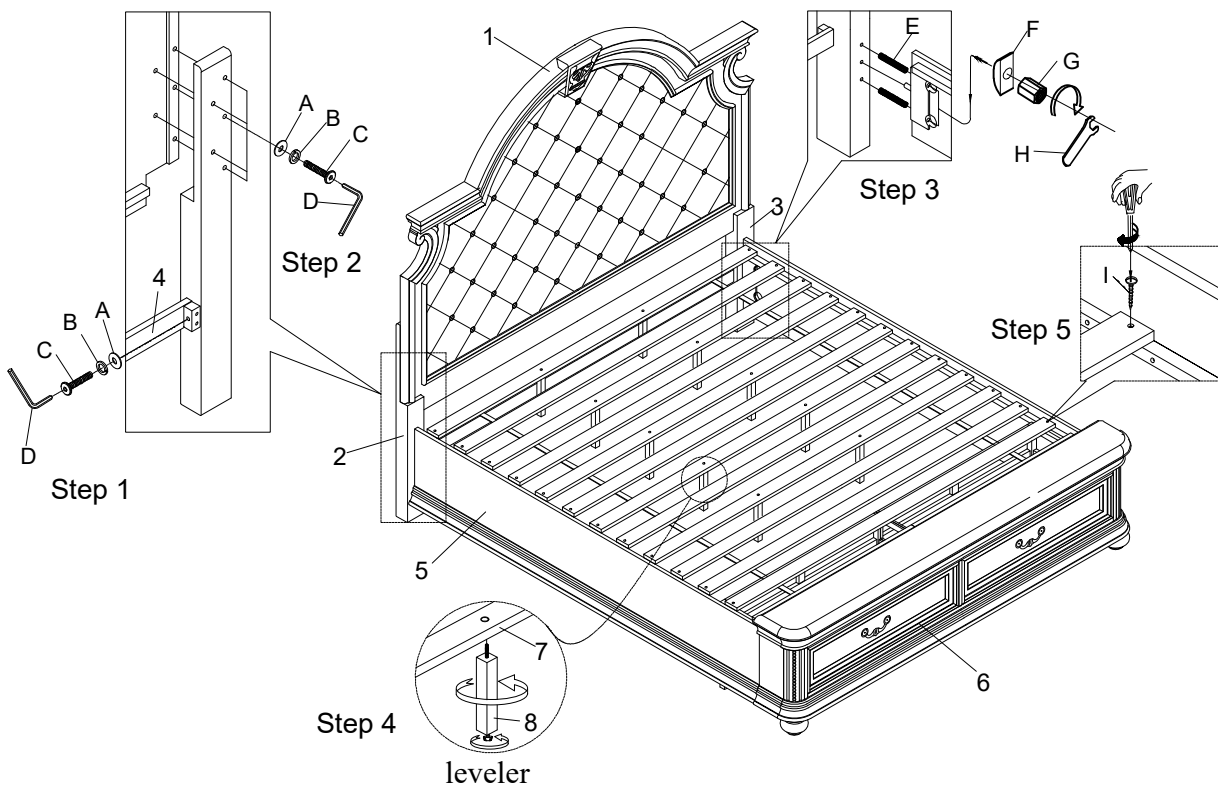

Do not fully tighten all screws and bolts until the entire item is completely assembled.