

# ASSEMBLY INSTRUCTIONS

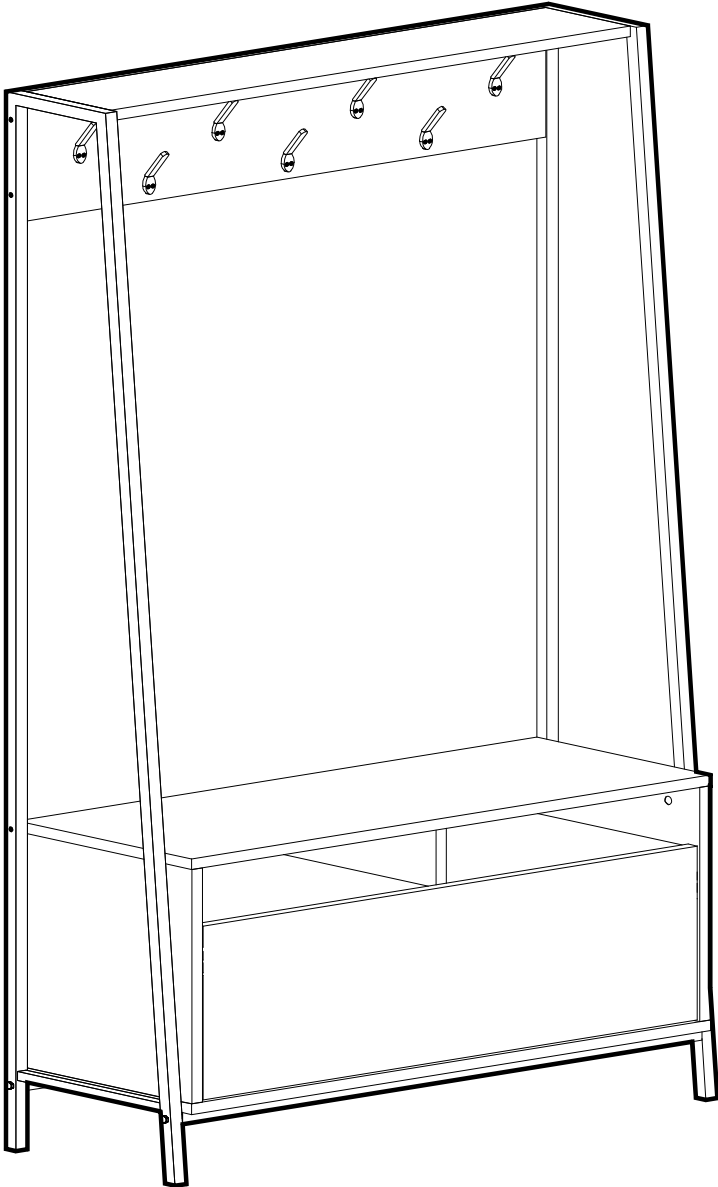



Valued Customer,

We design and carefully manufacture our products for our customers, We wish that our customers to have fun while they are doing their new furniture

The product you just purchased was subjected to all sorts of tests and controls before sending out to you.

Hope you enjoy your new furniture.



Before starting, please check all components and accessories according to the provided list. If you purchased more than one product, to prevent confusion, be sure that you completed the first product, then start the next one. Please make sure that you select correct numbered part and use specific connector to assemble. We do not recommend any modification or rotation in assembly. Please follow the manual carefully.



Furniture parts are going to several manufacturing procedures. During this process, parts can have little dust or marks. Please clean the parts with damp cloth before assembly to get the best result. Usual cleaning would be suffice.



Although all products are carefully manufactured and packed, sometimes we experience damage during transportation. In such cases, please check the damaged part, note the part number written on the part and do not hesitate to contact us



Do not use your furniture for out of purposes. If you would like to use it out of purpose or would like to do some modification or rotation, please contact us for more details.

Please do not expose your furniture with excessive heat, cold and humidity because product can be affected negatively.

If you need your product to mount on the wall, Please use suitable rawplug for your wall type. We send you rawplugs suitable for concrete and brick walls.

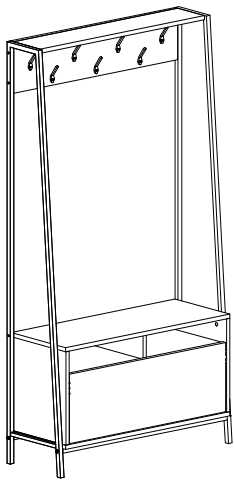

## Disassembled Parts

Part#1	1x
Part#2	1x
Part#3	1x
Part#4	1x
Part#5	1x
Part#6	1x
Part#7	1x
Part#8	1x
Part#9	1x





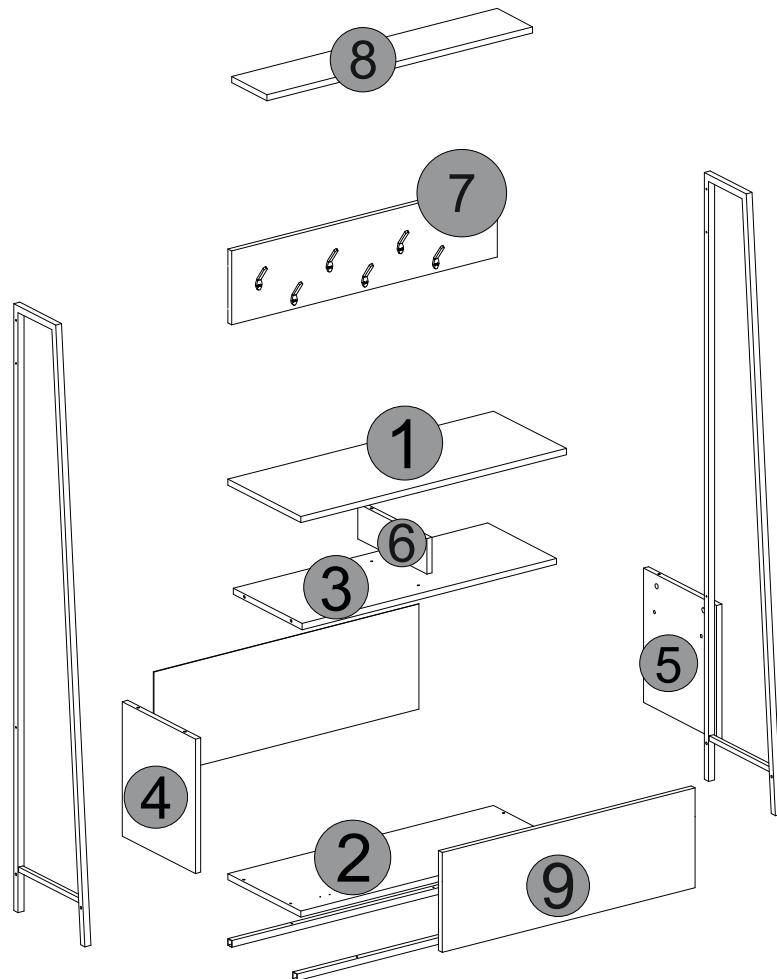

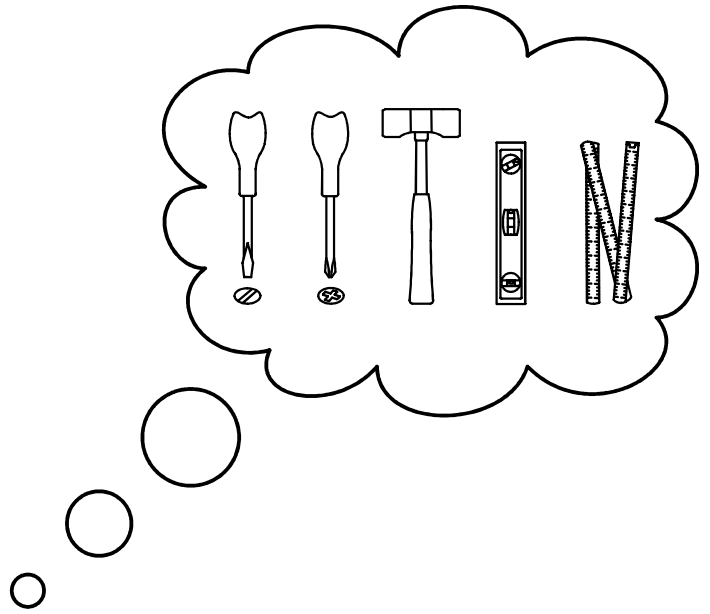
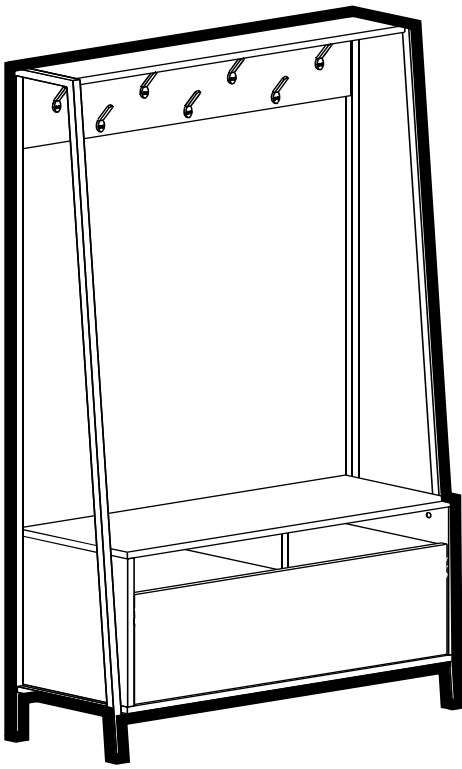



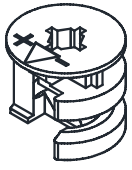
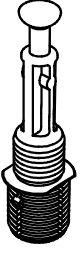

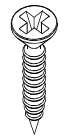
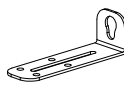
---

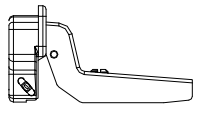
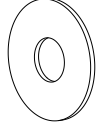
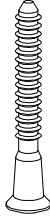
**Total**      **9x**

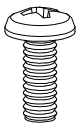

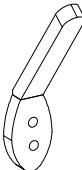
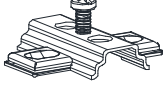

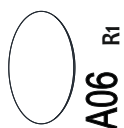
## Tools & Installation Components [36]

- |   |   |  |   |  |   |   |
|---|---|--|---|--|---|---|
|  |  |   |    |  |  |  |
| A02 15x14 head  | A03 Q8 Minifix  | A18 3,5x35 Screw   | A19 3,5x18 Screw  | L01 L-bracket  | A28 nail  | C2 inset hinge  |
| 10x   | 10x   | 4x   | 26x   | 1x   | 10x   | 2x  |
|  |  |   |    |   |  |  |
| V14 5x16 metal stamp  | A17 6x50 screw  | A23 4X50 Screw   | M3 m6x30 bolt   | D1 8x50 ROCKET ANCHOR  | mtd-094 Hanger  | C1 Pivot  |
| 1x  | 9x  | 8x   | 4x  | 1x   | 7x  | 2x  |
|  |  |  |  |  |   |   |
| A12 4.5W ALYN   | A42 5x70 screw  | A06 R1   | PLASTIC PLUG 20x20  |  |   |   |
| 1x  | 1x  | 19x  | 4x  |  |   |   |

# Step 1

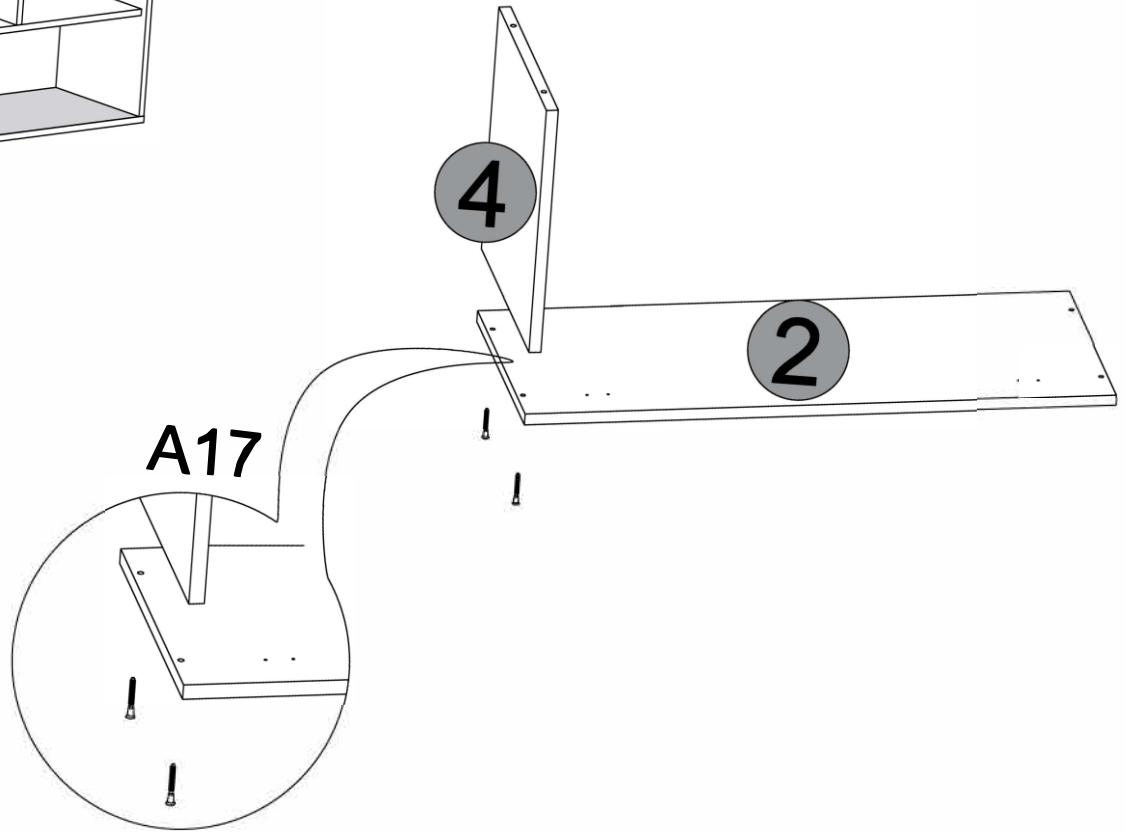
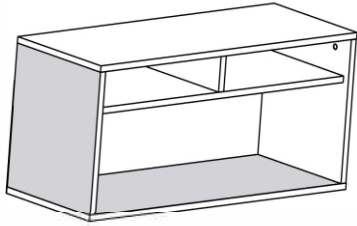

# Step 2

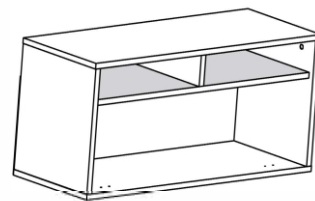
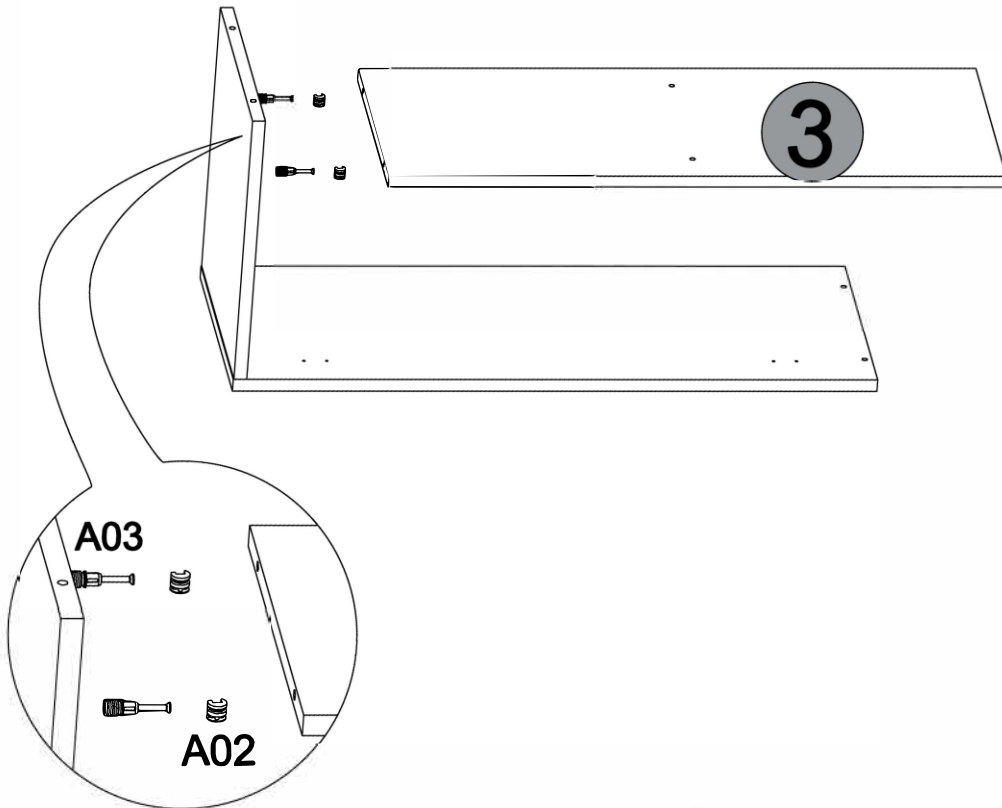

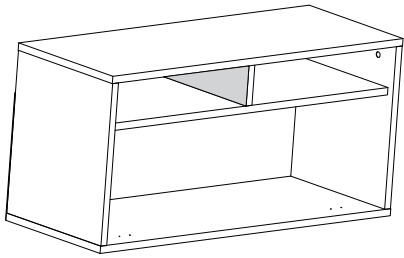

# Step 3

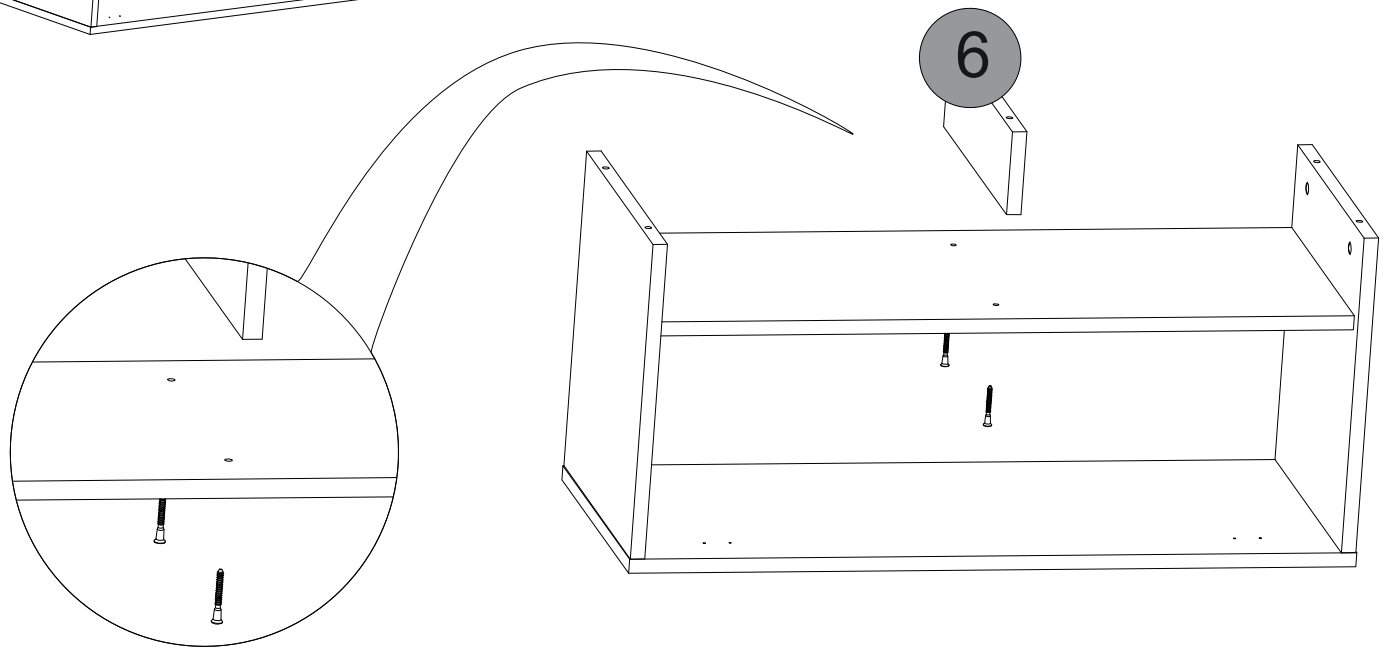

**A17**

# Step 4

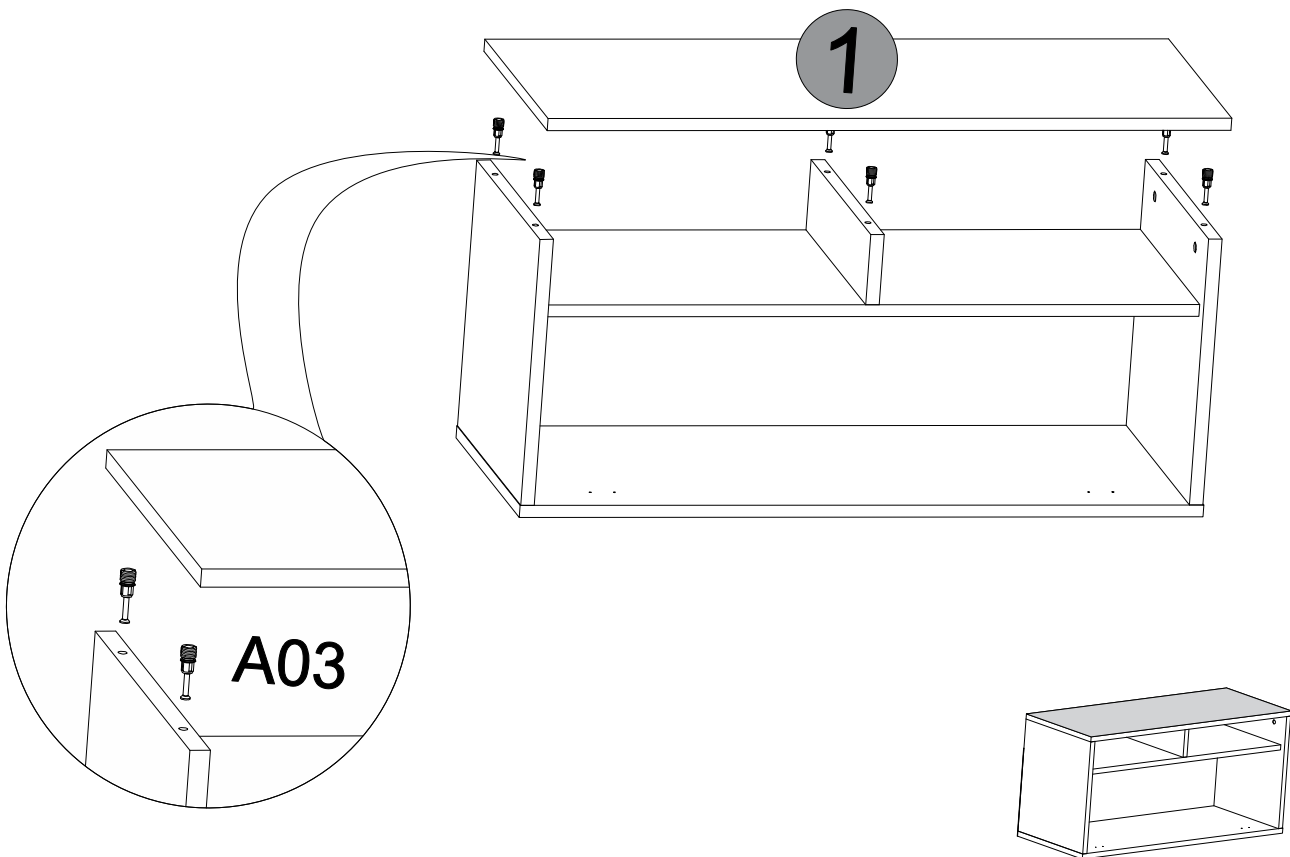

**A03**

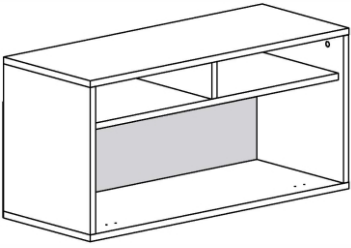

# Step 5

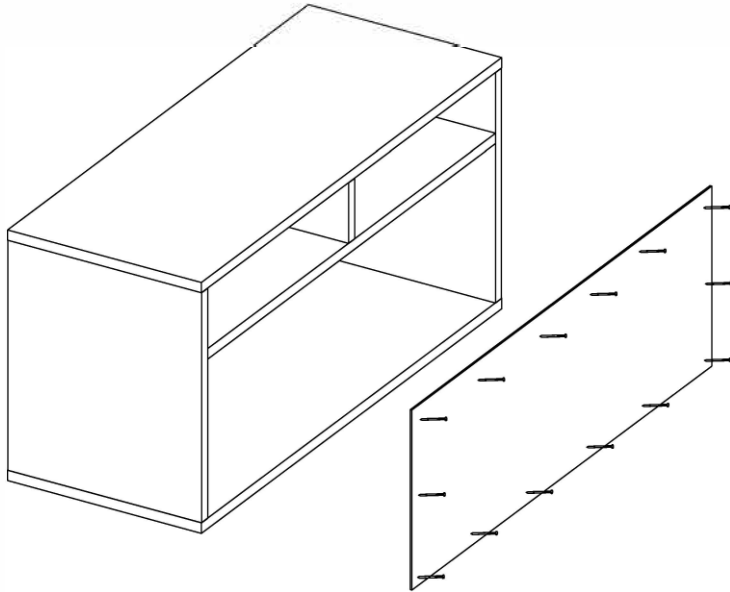

A28

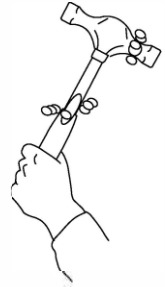

# Step 6

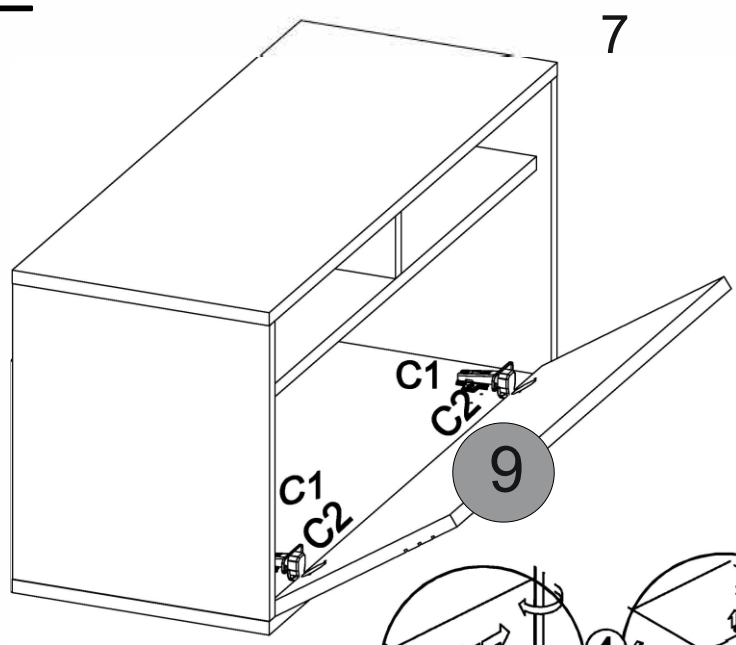

7

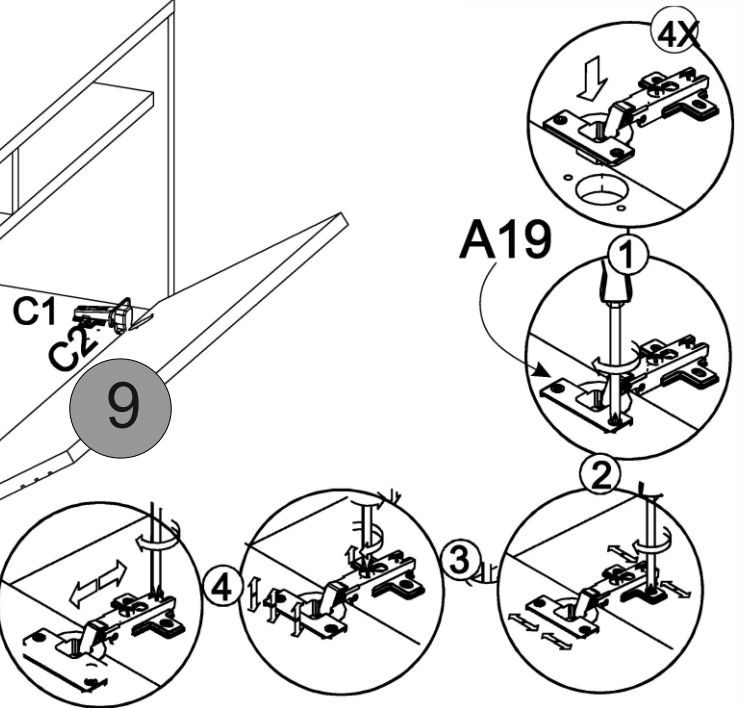

7

# Step 7

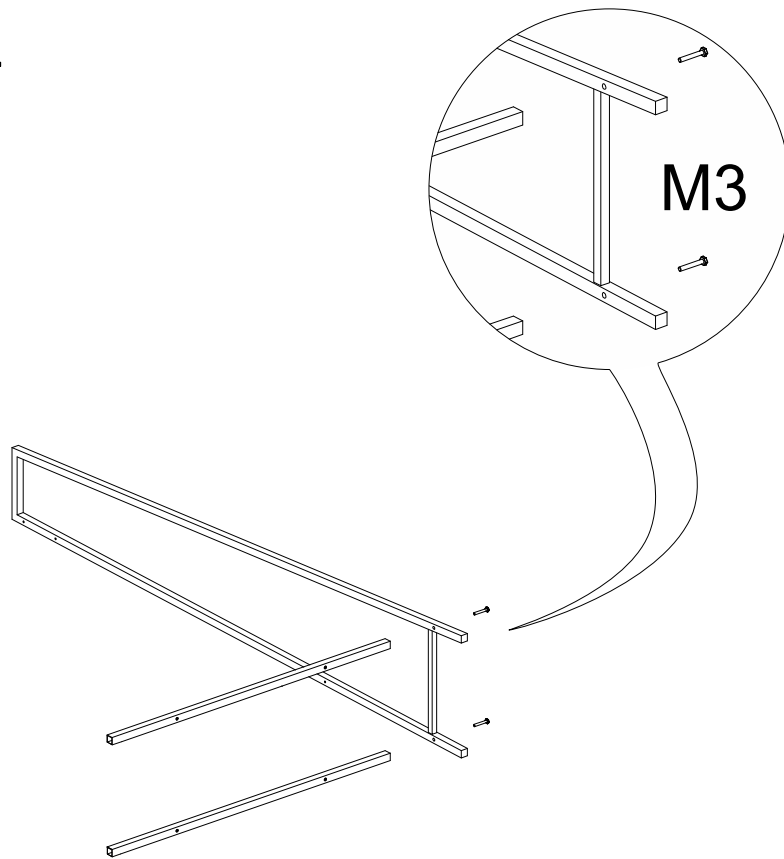

# Step 8

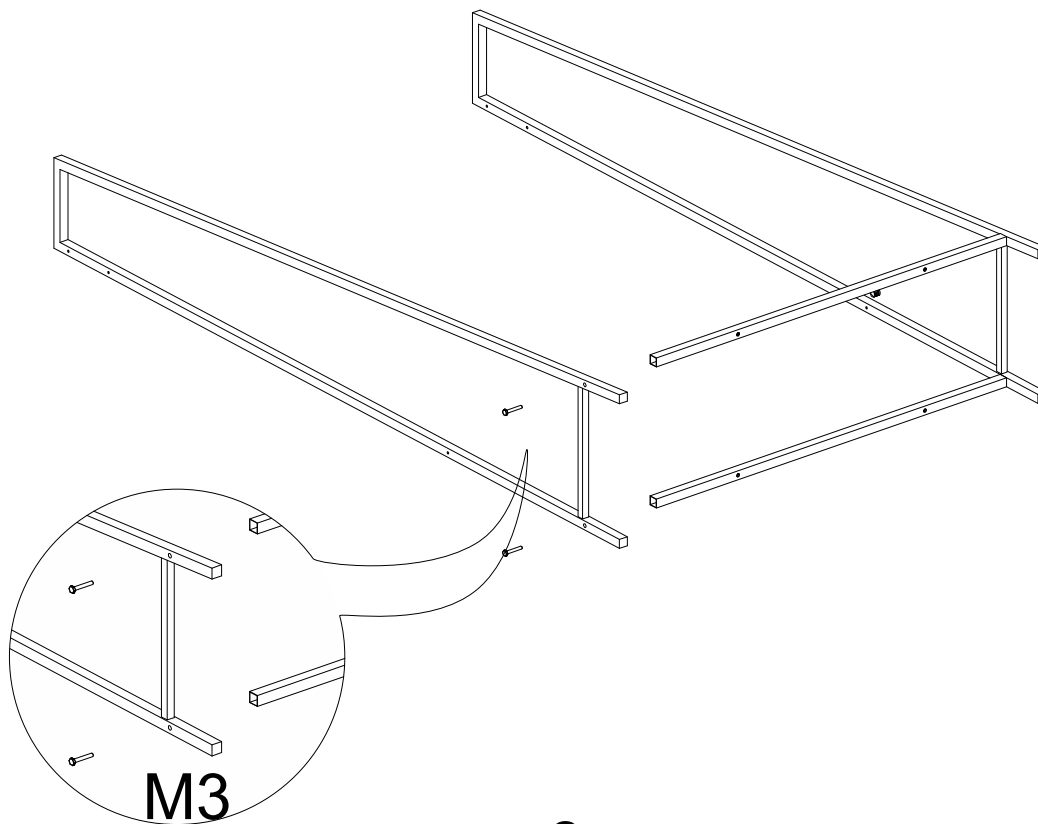

# Step 9

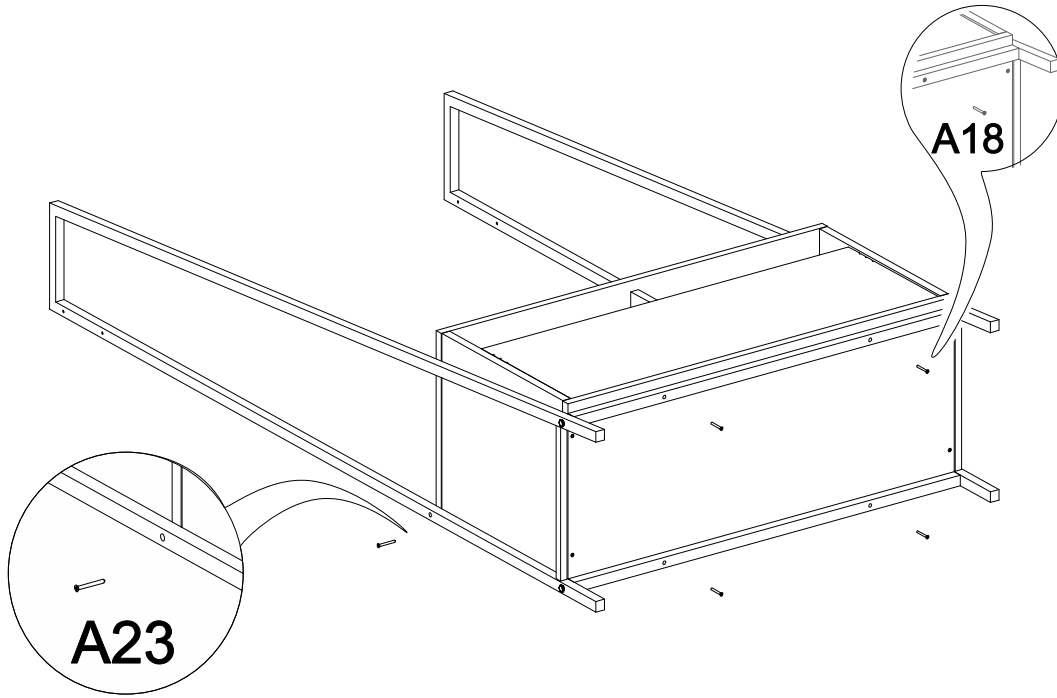

# Step 10

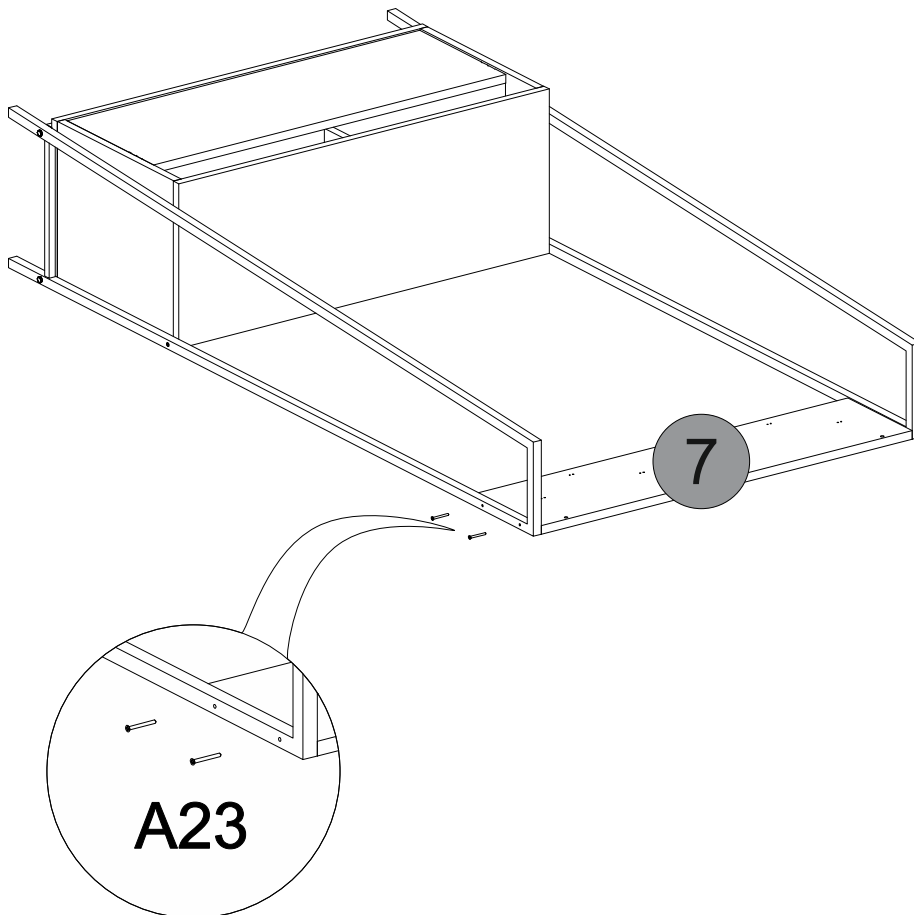

# Step 11

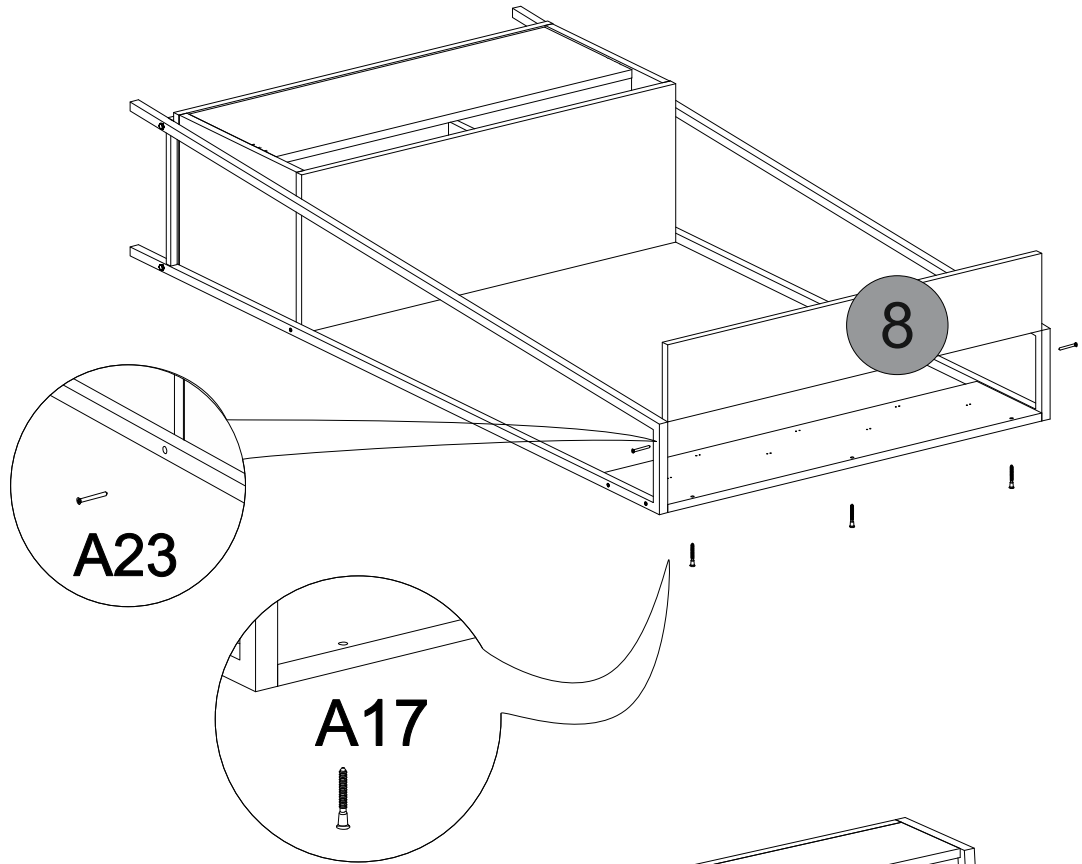

# Step 12

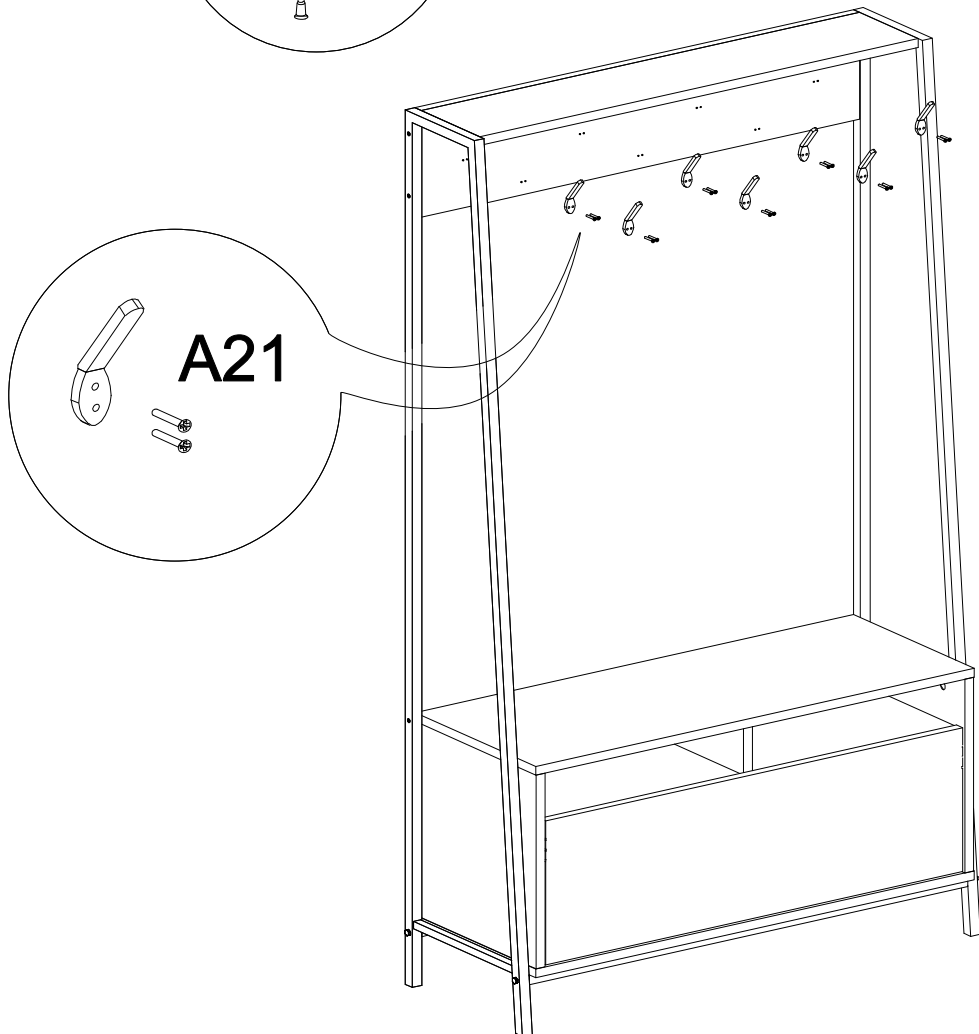

# Step 13

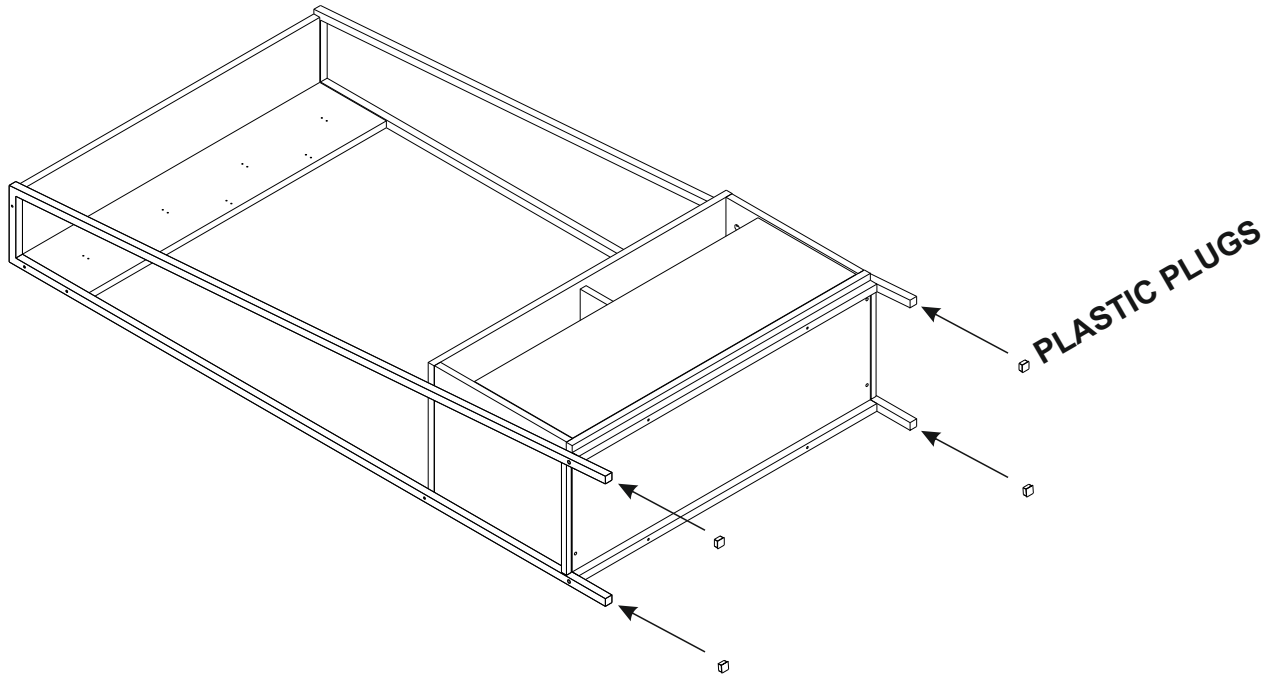

# Step 14

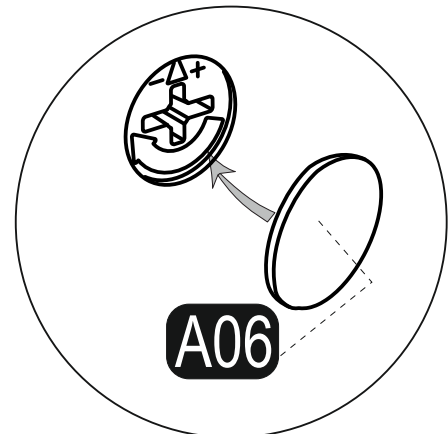
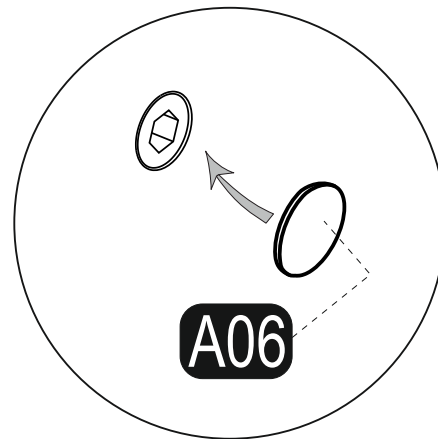
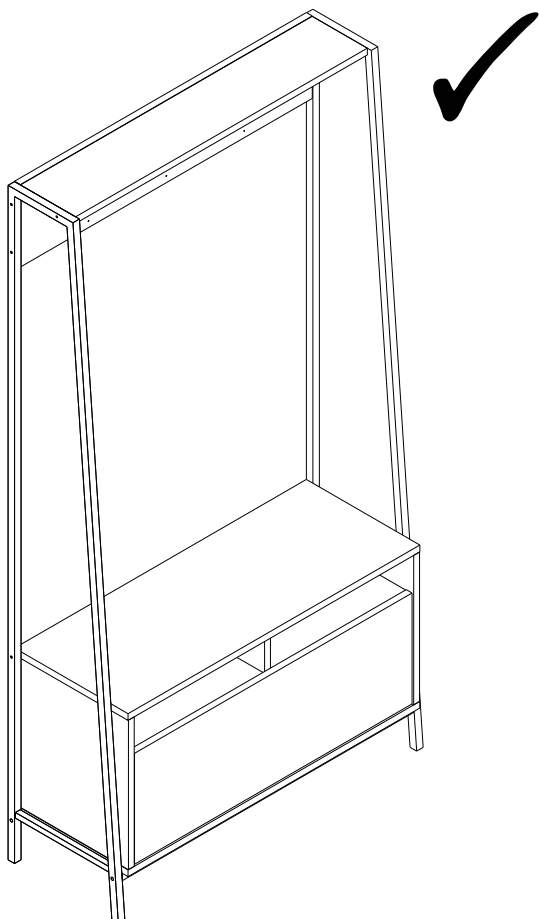

# Step 15

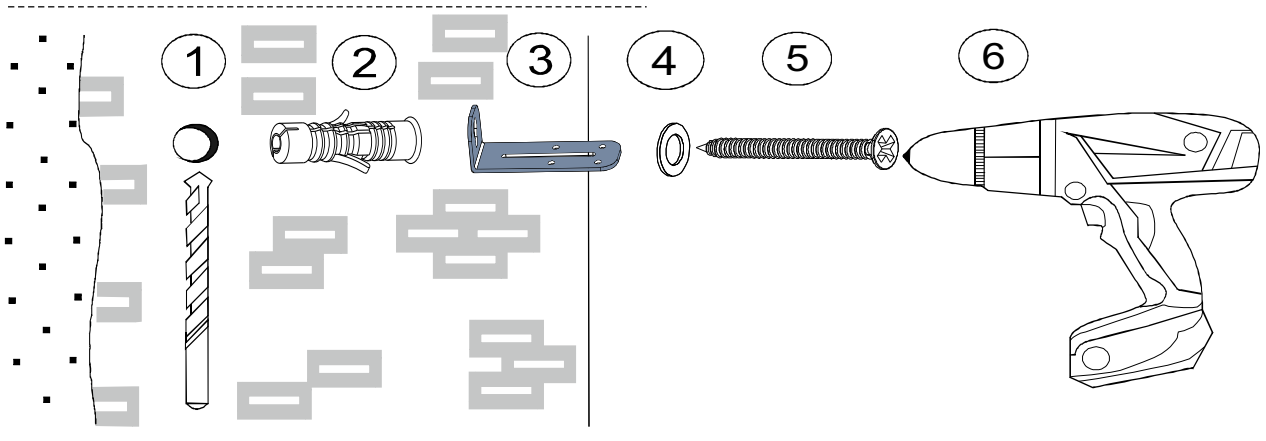
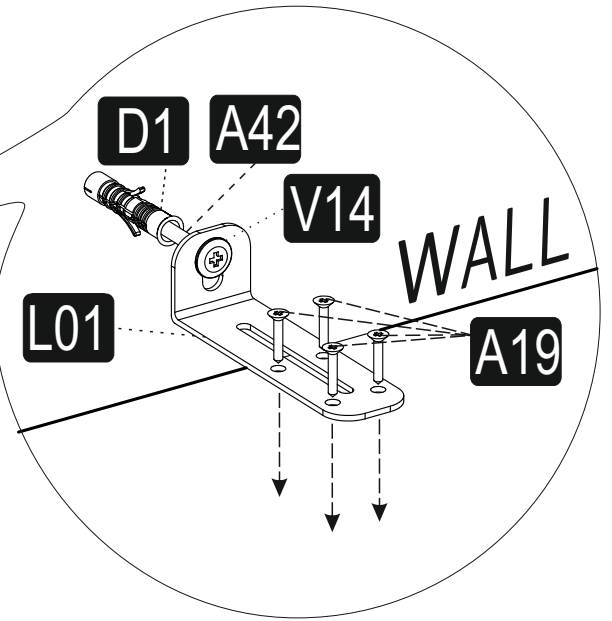
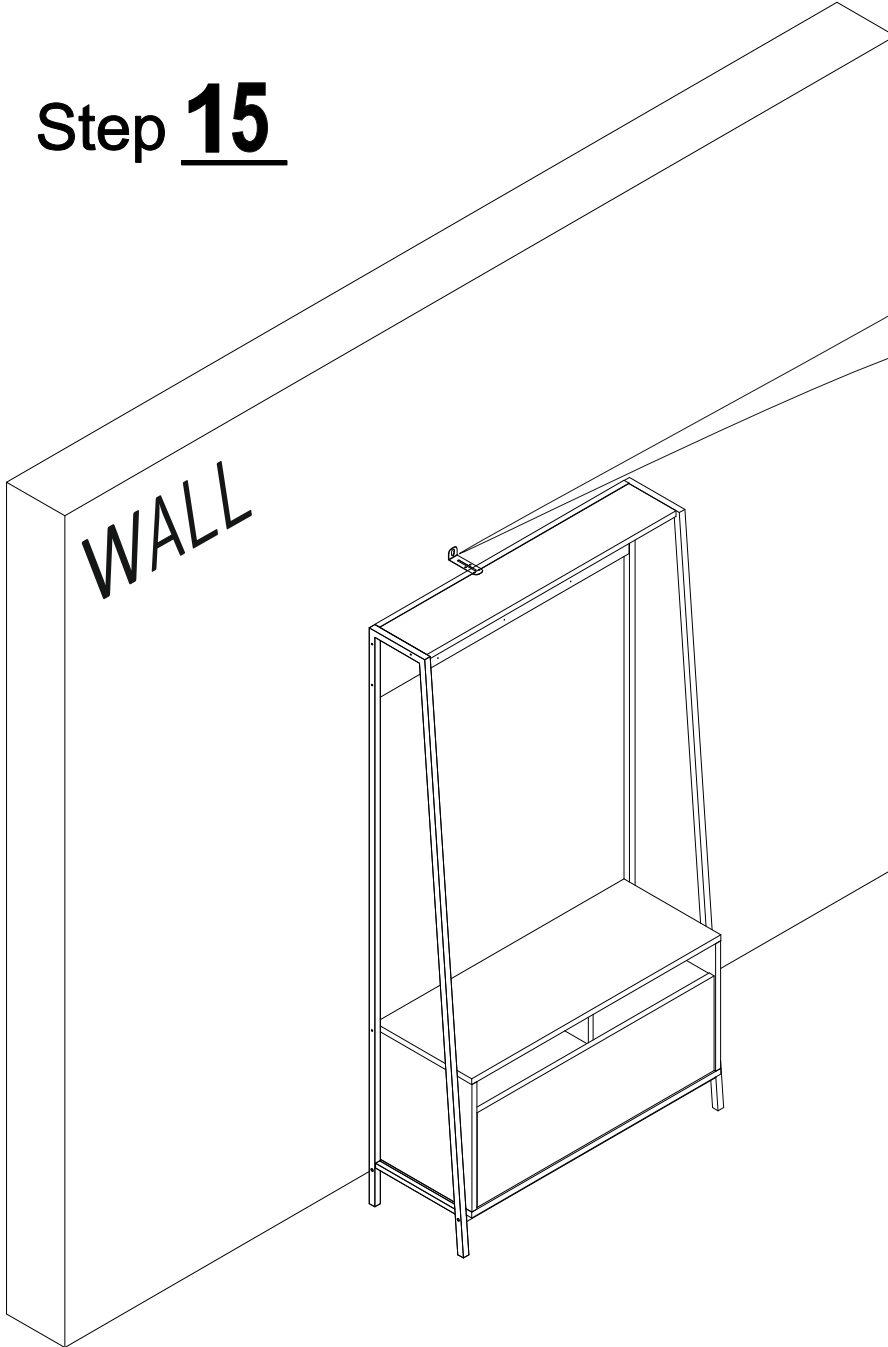

Check the Wall type before installation of dowel. Wall is drilled with equal diameter of dowel.(08mm) Universal Plastic Dowel provides the general purpose usage. Requires two stages assembly.  
Dowel can be different type according to the wall type. (e.g. Plaster Sheet Partition Wall, Gas Concrete, Hollow Brick Wall) If required, use appropriate dowels and screws.



# **WARNING**

## **CHOKING HAZARD**

- This unit contains small parts which could be a choking hazard for small children. Children should be under adult supervision at all times.
- Do not overload the unit. Each shelf has a recommended capacity of 13 pounds, and the total weight on the unit should not exceed 39 pounds for wall shelves.
- Do not climb, step, or stand on the unit.
- Do not mount or attach items to the front, rear, or sides of the unit. This can cause the unit to become unbalanced and fall.
- Do not stack units.
- All units must be secured individually to wall studs using hardware provided. If wall studs are not accessible, consult your local hardware store for appropriate mounting hardware.
- We recommend you hand-tighten screws. Use care not to overtighten if using power tools. Follow proper safety procedures if using power tools and/or ladders.
- We recommend you protect your work surface during assembly to prevent scratching or damage to tabletops, wood floors, etc.
- Failure to follow the instructions listed here could result in bodily injury or damage to personal belongings. Use caution and follow safety procedures.