

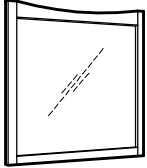





# ASSEMBLY INSTRUCTION DRESSER & MIRROR

Parts & Hardware		
No	Descriptions	Qty
A	Mirror 	1
B	Dresser 	1
C	Mirror Support 	2
D	JCBC M6 x 35mm 	8
E	Spring Washer Ø1/4" 	8
F	Flat Washer Ø1/4" x 20mm 	8
G	Allen Wrench M4 	1

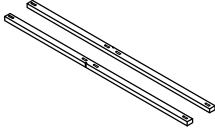
STEP 1 : ATTACH MIRROR SUPPORT (C) TO THE MIRROR BACK (A) AS STEP 1, THEN TIGHTEN WITH JCBC (D), SPRING WASHER (E) & FLAT WASHER (F) BY USING L KEY (G). MAKE SURE MARKING LINE OF SUPPORT MUST SAME LEVEL AS BOTTOM OF MIRROR BASE.

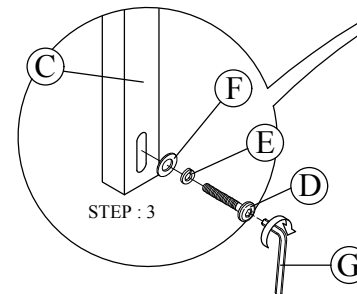
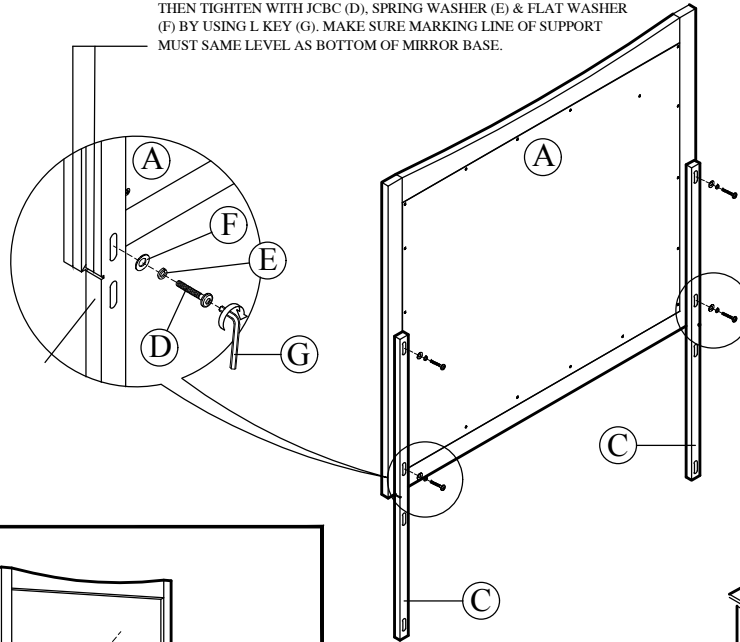

STEP 2 : PLACE THE MIRROR THAT WITH SUPPORT ON THE TOP OF DRESSER (B). THEN ALIGN CENTER, AS SHOWN AND TIGHTEN WITH JCBC (D), SPRING WASHER (E) & FLAT WASHER (F) BY USING L KEY (G).

