

User Manual

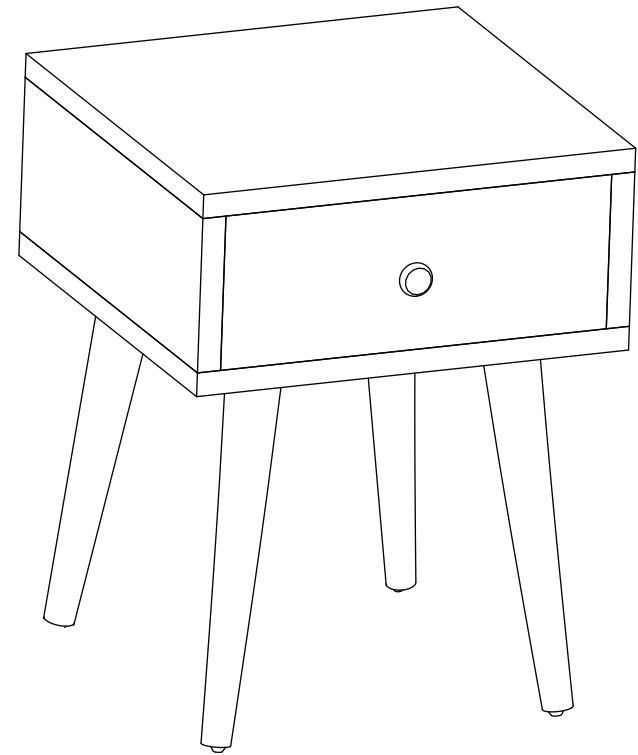

You need

1 Tools required

A Phillips head screwdriver is required for the assembly of this product. (not included)

Power tools should not be used to assemble this product.

2 1 person are needed

3 Take 30 minutes

Technical Specifications

Material	MDF
Size	400*300*580mm
Max weight capacity	65LBS

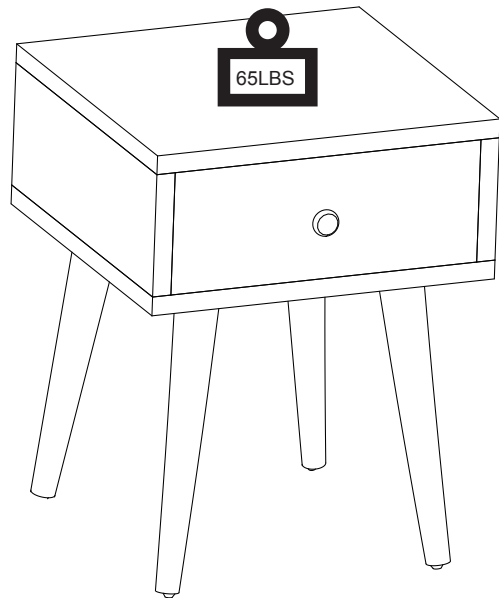

Hardware List

A 1PC	B 1PC	C 1PC	D 1PC
E 1PC	F 4PCS	G 1PC	H 1PC
I 1PC	J 1PC	K 1PC	
① 8PCS	② 8PCS	③ 8PCS	④ 8PCS
⑤ 1PC	⑥ 1PC	⑦ 1PC	⑧ 1PC

PRODUCT ASSEMBLY

! Check the package contents before getting started !

STEP 1

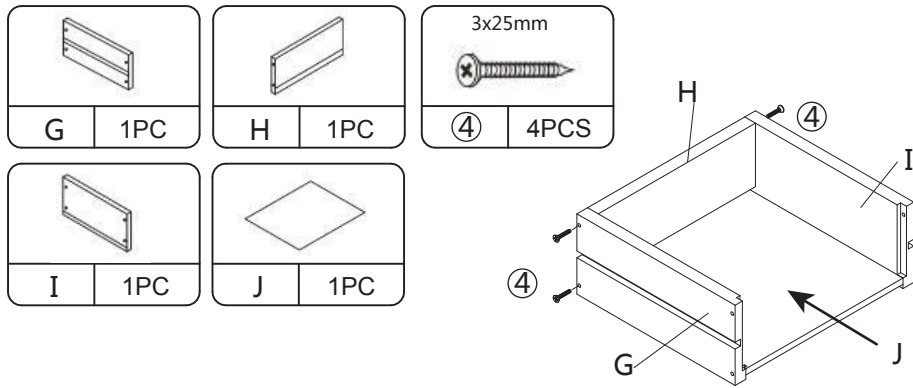

STEP 2

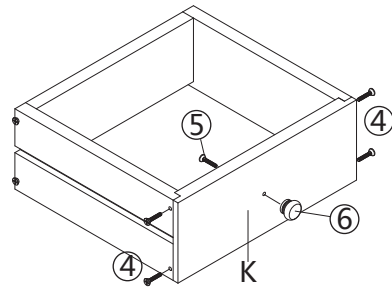
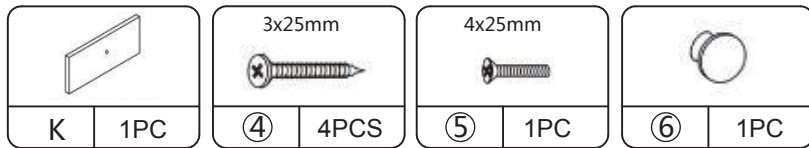

PRODUCT ASSEMBLY

STEP 3

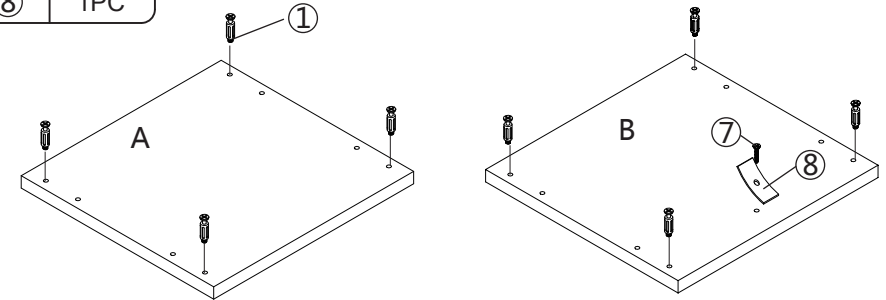
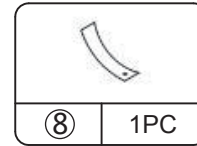
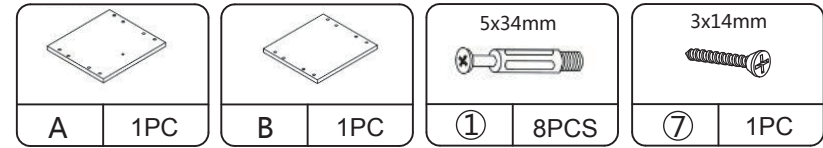

STEP 4

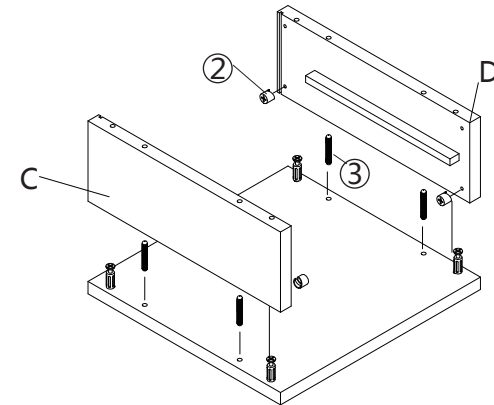
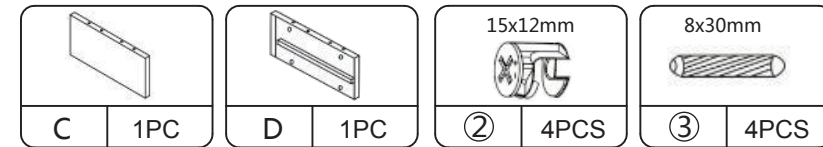

STEP 5

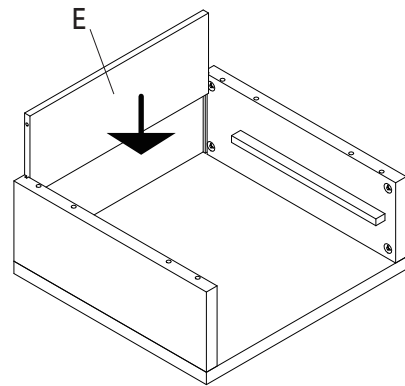
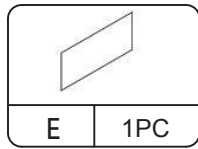

STEP 6

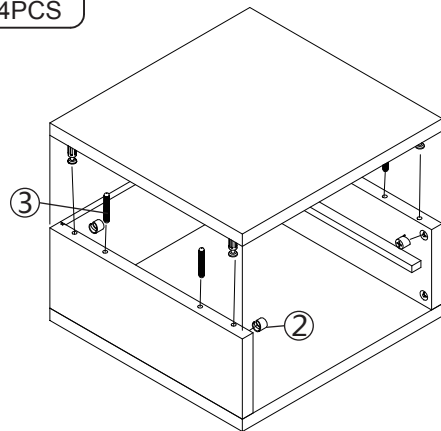
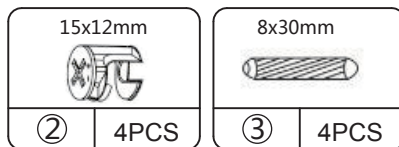

STEP 7

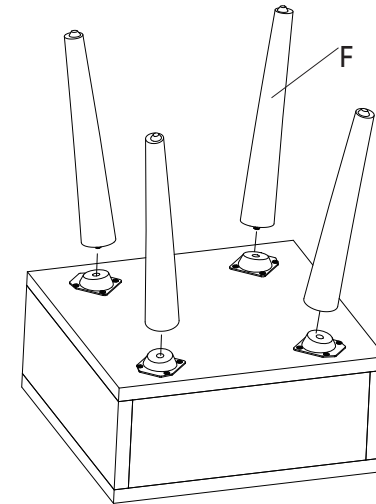
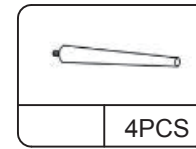

STEP 8

