

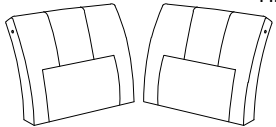











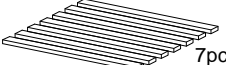

ASSEMBLY INSTRUCTION

NO	PART LIST	QTY
1	HB&FB 	2pcs
2	BACK REST 	1pc
3	FRONT RAIL 	1pc
4	BACK RAIL 	1pc
5	SLAT 7pcs 	2pcs
6	LEG 	4pcs
NO	HARDWARE LIST	QTY
A	SCREW M4 x 32mm 	8pcs
B	JCBB SCREW M8 x 20mm 	8pcs
C	JCBC SCREW M6 x 35mm 	4pcs
D	JCBC SCREW M6 x 45mm 	4pcs
E	SPRING WASHER 1/4" x Ø12mm 	4pcs
F	FLAT WASHER 1/4" x Ø19mm 	4pcs
G	L - KEY M5 x 65mm 	1pc
H	L - KEY M4 x 65mm 	1pc

STEP 1 Begin assembly by attaching each Leg (6) to the bottom of the HB&FB (1) securing with 2 Allen Bolt (D) per panel.

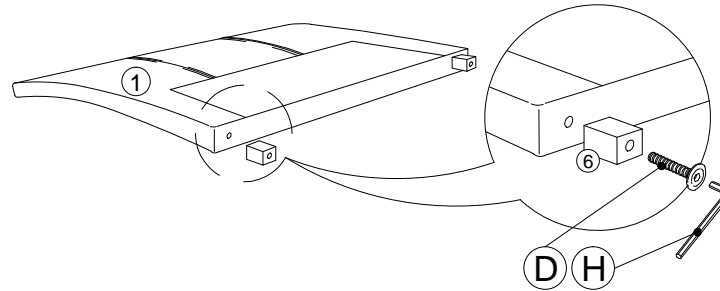

STEP 2 Attach the Front Rail (3) and Back Rail (4) to the HB&FB (1) aligning holes and securing with 2 Allen Bolts (B) per each end. (DO NOT FULLY TIGHTEN BOLTS FOR THIS STEP)

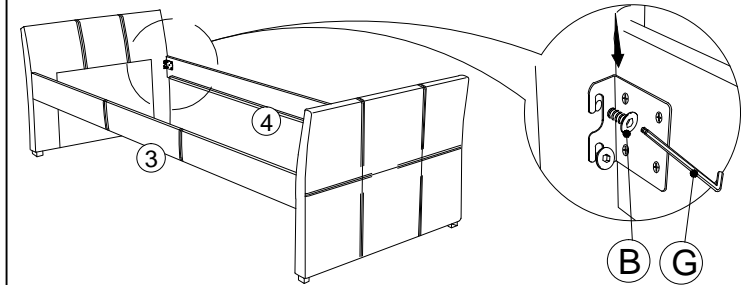

STEP 3 Attach the Back Rest (2) to the back of each HB&FB (1) by aligning the hole and securing with 2 Allen Bolt (C), 2 Spring Washer (E), 2 Flat Washer (F) from the back side per each end. (DO NOT FULLY TIGHTEN BOLTS FOR THIS STEP)

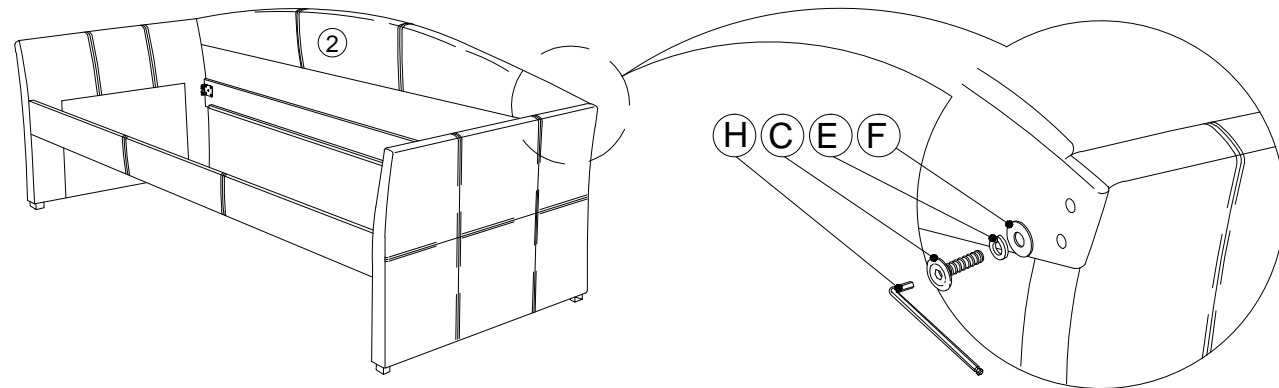

STEP 4 Tighten all bolts from STEP 2 using the Allen Wrench (G) that has been provided. Now only tighten bolts for STEP 3 using Allen Wrench (H). Attach Slat (5) to Front Rail (3) and Back Rail (4) by unrolling and securing with 4 Wood Screws (A) 2 per each side. Tighten all screws using philips head screwdriver (not included)

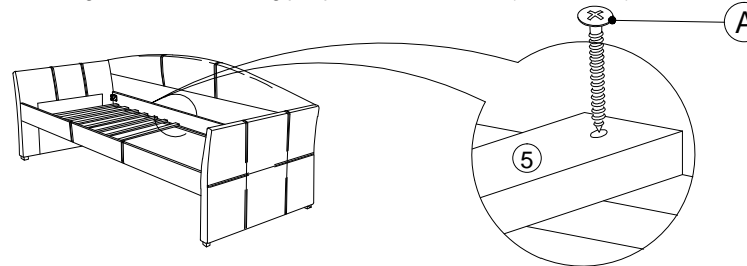

Your new day bed is now complete

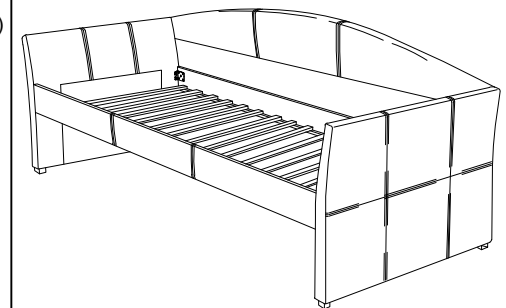

NOTE: AFTER A FEW DAYS OF ASSEMBLY, IT WILL HAVE ACCLIMATIZED TO THE ENVIRONMENT. PLEASE TIGHTEN ALL HARDWARE. CHECK TIGHTNESS OF ALL SCREWS EVERY 6-8 WEEKS.

ASSEMBLY INSTRUCTION

NO	PART LIST	QTY
1	FRONT RAIL	1pc
2	BACK RAIL	1pc
3	SIDE RAIL	2pcs
4	SLAT 7pcs	2pcs
NO	HARDWARE LIST	QTY
A	CASTOR	6pcs
B	CHIPBOARD SCREW M4 x 16mm	24pcs
C	SCREW M4 x 32mm	8pcs
D	JCBB SCREW M8 x 20mm	8pcs
E	L - KEY M5 x 65mm	1pc

STEP 1 Begin assembly by attaching each Castor (A) to the bottom of the Front Rail (1) and Back Rail (2) using 4 Wood Screw (B) per Castor.

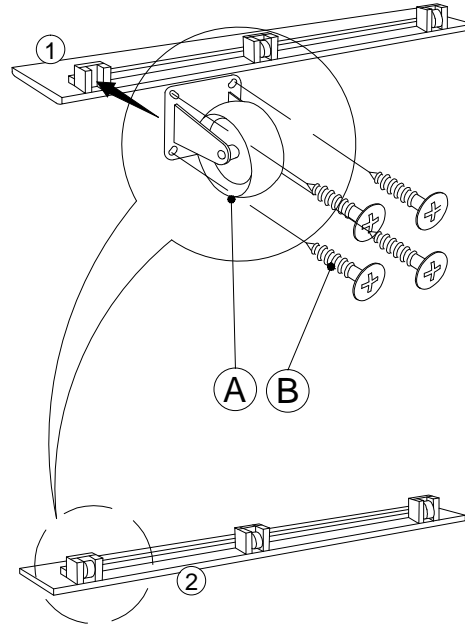

STEP 2 Attach the Front Rail (1) and Back Rail (2) to the Side Rail (3) aligning holes and securing with 2 Allen Bolts (D) per each end. Tighten all bolts using the Allen Wrench (E) that has been provided.

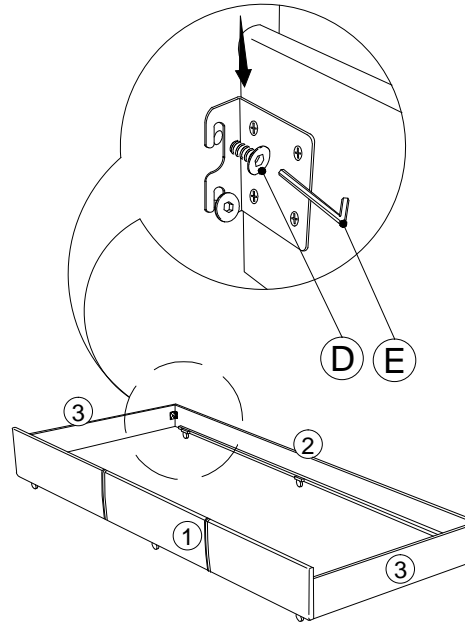

STEP 3 Attach Slat (4) to Front Rail (1) and Back Rail (2) by unrolling and securing with 4 Wood Screws (C) 2 per each side. Tighten all screws using philips head screwdriver (not included)

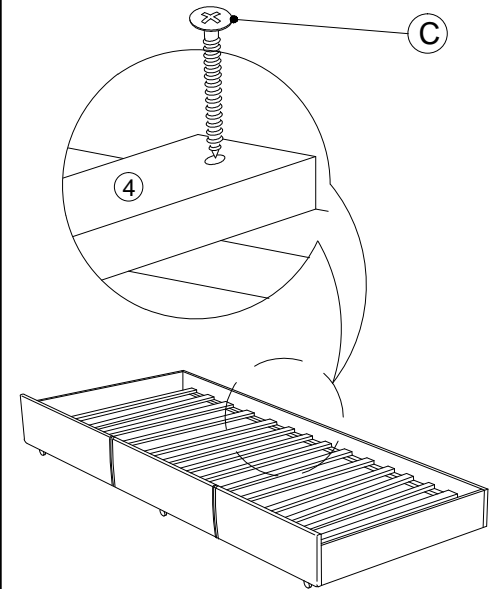

Your new day bed trundle unit is now complete

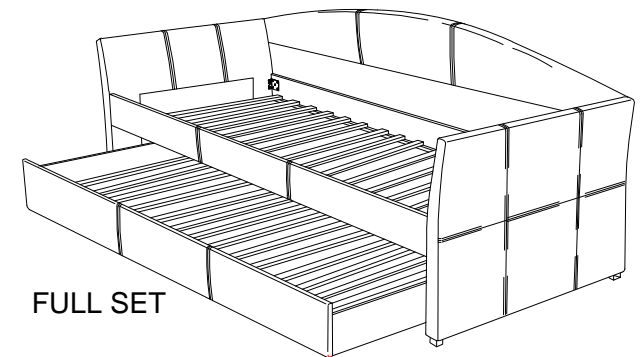
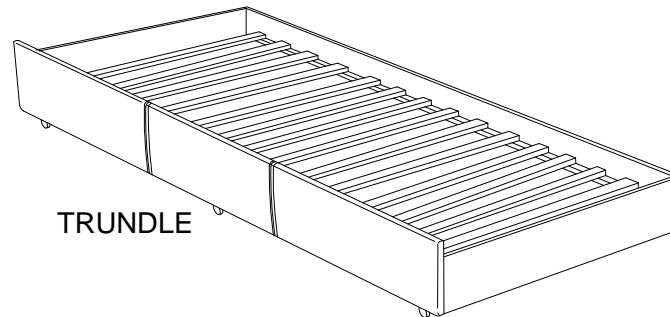

NOTE: AFTER A FEW DAYS OF ASSEMBLY, IT WILL HAVE ACCLIMATIZED TO THE ENVIRONMENT. PLEASE TIGHTEN ALL HARDWARE. CHECK TIGHTNESS OF ALL SCREWS EVERY 6-8 WEEKS.