

Assembly Instructions

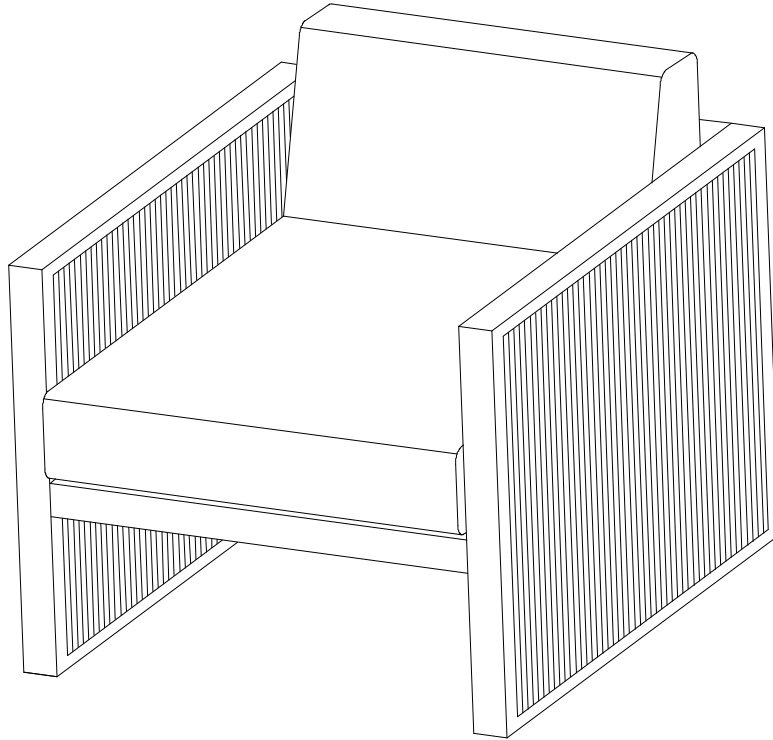







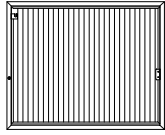

For any missing hardware, damaged parts and other problems.
WELCOME to email us at: service@behousewell.com

Or call at 1-888-733-8169 Toll free
Between 9AM and 5PM Eastern time, Monday through Friday

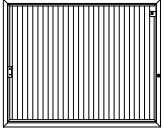
***Don't fully tighten all the bolts till the very end!**

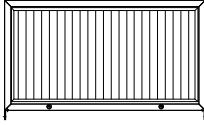

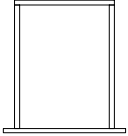
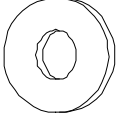
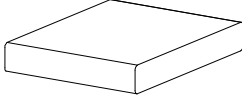
PRE-ASSEMBLY PREPARATION:

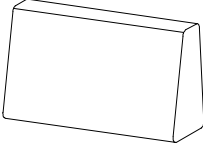
- Please read through the instructions before beginning assembly.
- Clear out the space for assembly and lay out all of the parts based on the Parts List, extra room will allow you to easily determine if all the pieces are present.
- Keep small parts and pieces away from children until fully assembled.

Part no.	Part	QTY	Image	Part no.	Part	QTY	Image
A1	Left arm	1		F	Bolt (M6*40mm)	2	
A2	Right arm	1		G	Bolt (M6*20mm)	2	
B	Back	1		H	Bolt (M6*15mm)	6	
C	Seat	1		I	Washer M6	8	
D	Seat cushion	1		J	Allen wrench	1	
E	Back cushion	1					

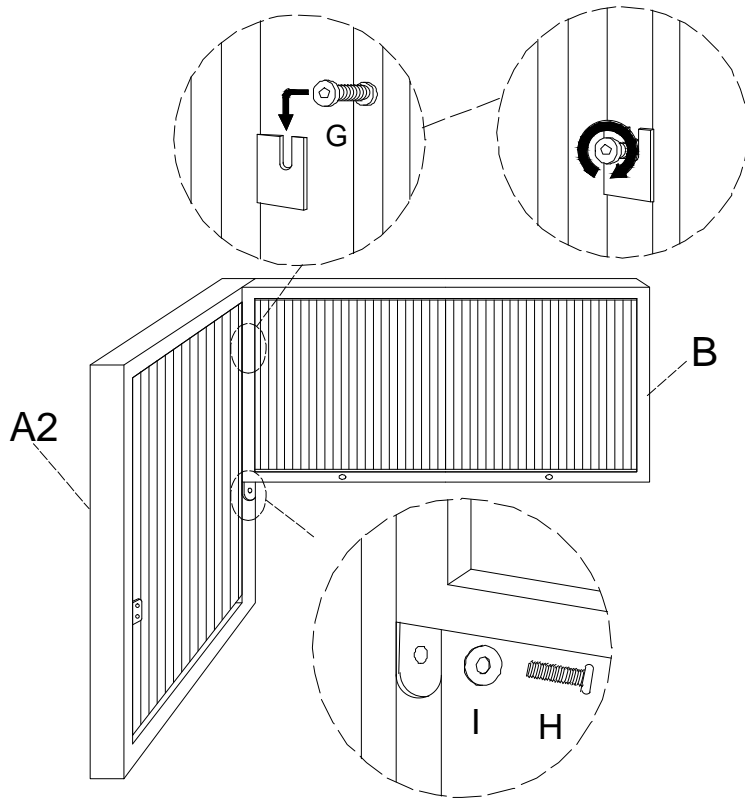

Step 1: Attach part A2 to part B with 1pc bolt H, 1pc bolt G and 1pc washer I, using Allen wrench J. Note: Don't fully tighten the bolts.



H		M6*15	1
G		M6*20	1
I		Ø16*Ø6.5*1	1

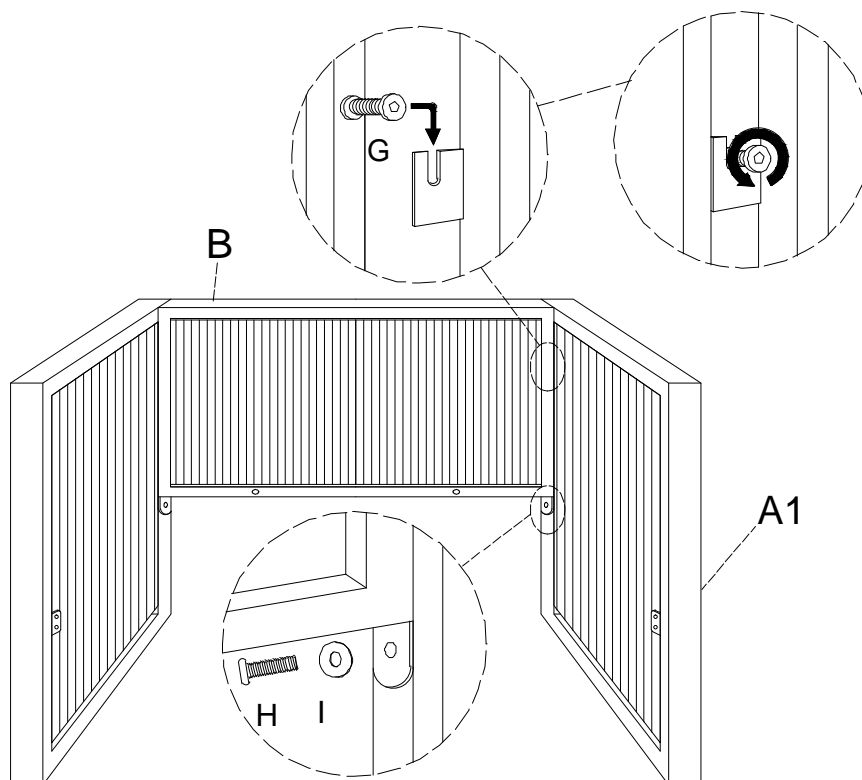

Step 2: Attach part A1 to part B with 1pc bolt H, 1pc bolt G and 1pc washer I, using Allen wrench J. Note: Don't fully tighten the bolts.

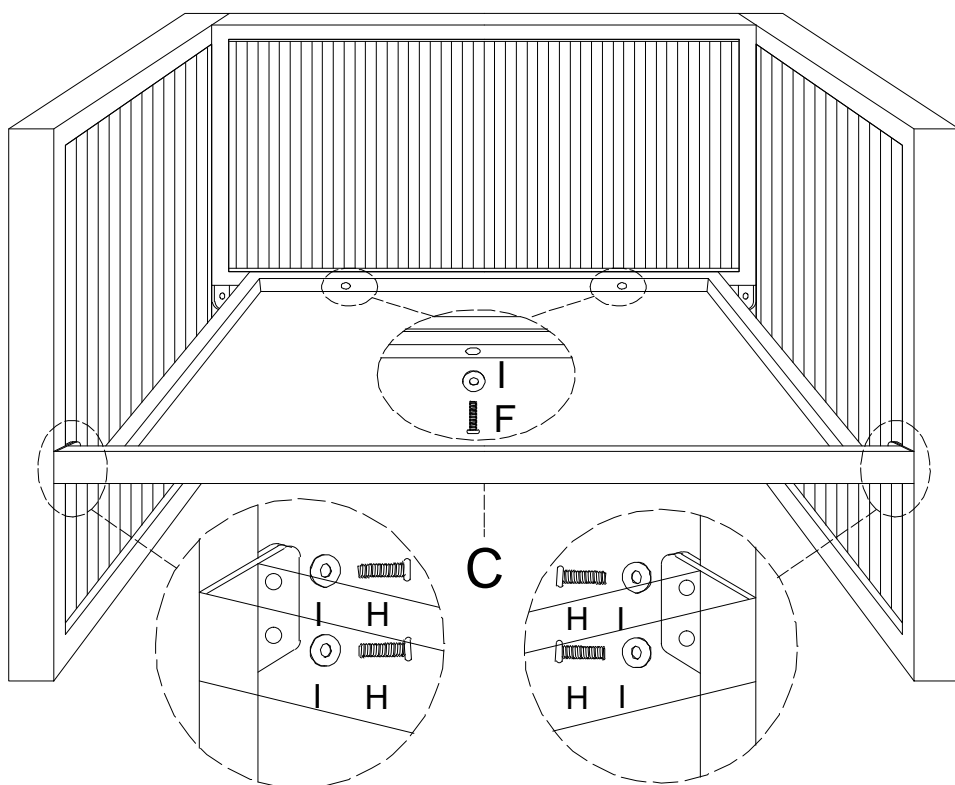

H		M6*15	1
G		M6*20	1
I		Ø16*Ø6.5*1	1

Step 3: Attach seat C to back and arms with 2pcs bolts F, 4pcs bolts H and 6pcs washers I, using Allen wrench J. Note: Please fully tighten all the bolts.



F		M6*40	2
H		M6*15	4
I		Ø16*Ø6.5*1	6

Step 4: Put back cushion E and seat cushion D onto the seat. Assembly is now complete and the product is ready for use.

