

# COFFEE TABLE

## ASSEMBLY INSTRUCTIONS

### PARTS AND FITTING PACKAGING DETAIL

#### BOX #1

A. TABLE TOP 1PC

B. LEGS 2PCS

C. CENTER RAIL 1PC



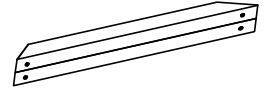
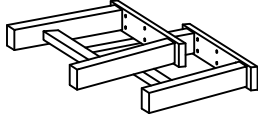
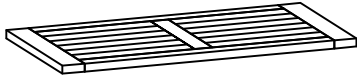

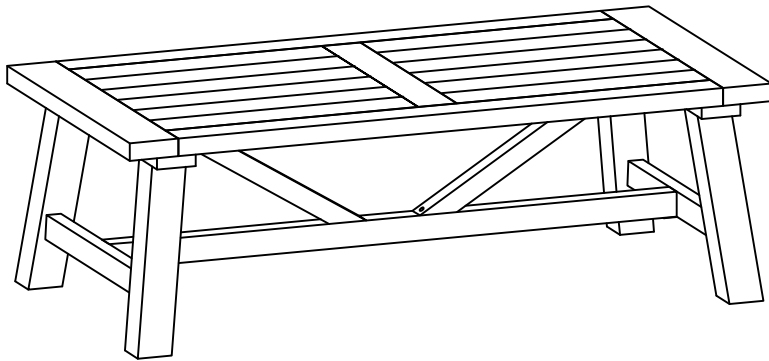

D. SUPPORT 2PCS  
BRACE



#### COFFEE TABLE ASSEMBLED

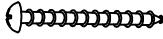

#### HARDWARE \* PACKED IN BOX #1

H1	ALLEN BOLT 8 X 50mm	12 PCS	H2	FLAT WASHER M8	12 PCS
					
H3	ALLEN KEY M4	1 PC	H4	SCREW 4 X 20mm	4 PCS
					
H5	SCREW 4 X 40mm	4 PCS	H6	SPRING WASHER M8	12 PCS
					

**YOUR BOX MAY CONTAIN EXTRA HARDWARE**

#### STEP 1

Attach Legs (B) using Allen Bolts (H1), Flat Washers (H2), and Spring Washers (H6). Tighten with Allen Key (H3).

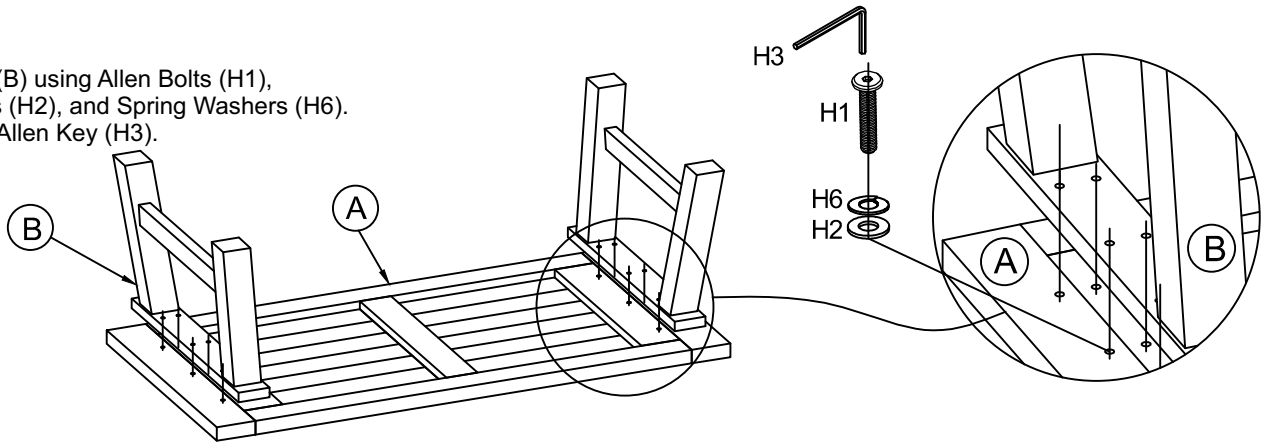

#### STEP 2

Following the illustration, attach Center Rail (C) to the Legs with Screws (H4). After securing the Center Rail, attach Support Braces (D) to the Table Top and Center Rail using Screws (H5). Screwdriver is not provided.

