

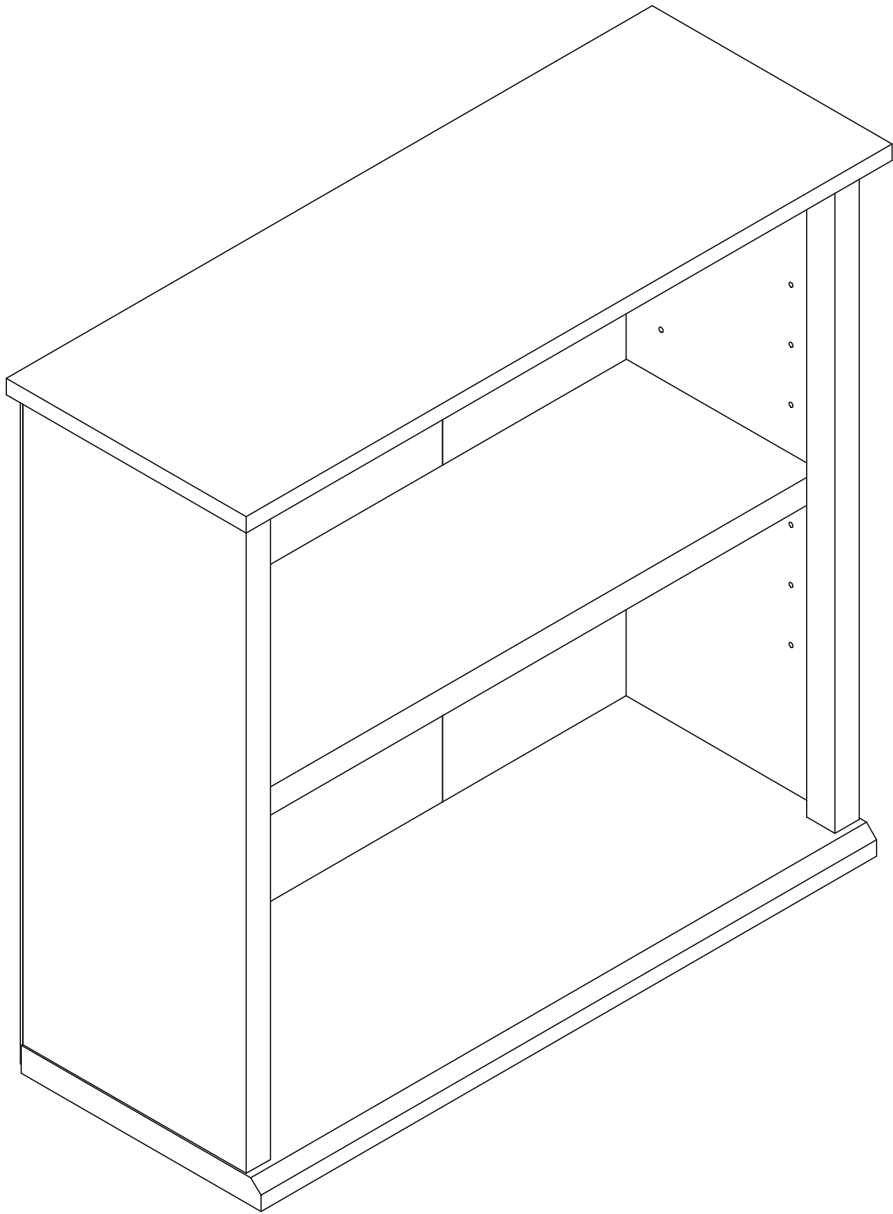



**ASSEMBLY INSTRUCTIONS / INSTRUCTIONS
D'ASSEMBLAGE / INSTRUCTIVO DE ARMADO**



NOTES ON ASSEMBLY / NOTES POUR L'ASSEMBLAGE / NOTAS SOBRE EL ENSAMBLE

- To ensure ease of assembly read all instructions before assembly and follow step by step illustrations.
- Keep instructions for future use.
- Adult assembly required. 
- Due to the presence of small parts during assembly, keep out of reach of children until assembly is complete.

- Pour assurer l'assemblage facile veuillez lire toutes les instructions avant l'assemblage et veuillez suivre les illustrations pour chaque étapes.
- Veuillez garder ces instructions pour l'usage ulterieur.
- Assemblage requis pas un adulte. 
- Due a la presence de petite pieces durant l'assemblage, veuillez garder hors de porter des enfants jusqu'a ce que l'assemblage soit completer.

- Para garantizar la facilidad de ensamble lea las instrucciones antes de iniciar y siga paso a paso las ilustraciones.
- Guarde las instrucciones para futuras referencias.
- El ensamble requiere de un adulto. 
- Debido a que hay piezas pequeñas, mantenga fuera del alcance a los niños durante el ensamble, hasta que haya terminado.

MAINTENANCE TIPS / CONSEILS D'ENTRETIEN / CONSEJOS DE MANUTENIMIENTO

- Never let liquids or damp cloths sit on this furniture.
- Never use chemical cleaning products. They can damage the finish. For cleaning, use only a slightly damp cloth and wipe dry.
- To avoid dulling of the finish, do not place furniture in direct sunlight.
- Do not put plastic or rubber rings under appliances. Use cloth of felt protectors.
- To clean, use a soft or slightly damp cloth, then wipe with a clean, dry cloth.

- Ne jamais laisser de liquide ou linge humide sur le meuble.
- Ne jamais utiliser de nettoyeurs à base de produits chimiques, cela va endommager le fini. Utiliser seulement un linge légèrement humide.
- Ne pas placer le meuble directement au soleil pour prévenir le ternissement.
- Évitez de déposer des appareils avec des rondelles de plastique ou de caoutchouc. Utilisez un protecteur en tissu ou en feutre.
- Pour nettoyer, utilisez un linge doux ou légèrement humecté. Essuyez par la suite avec un linge propre et sec.

- Nunca deje un líquido o un trapo húmedo sobre el mueble.
- Nunca utilice limpiadores a base de químicos, estos dañaran le acabado. Use sólo un paño húmedo.
- No esponga el mueble directamente al sol para prevenir empañamiento.
- Evite apoyar aparatos con redondeles de plástico o de goma. Utilizar un protector de tela o de fieltro.
- Para limpiar, utilice un trapo suave o ligeramente humedecido. Seque luego con un trapo limpio y seco.

⚠ WARNING ⚠ AVERTISSEMENT / ADVERTENCIA

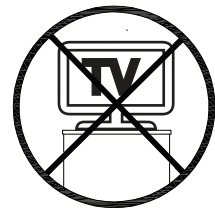
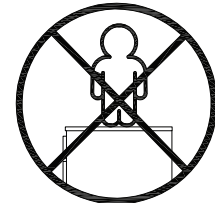
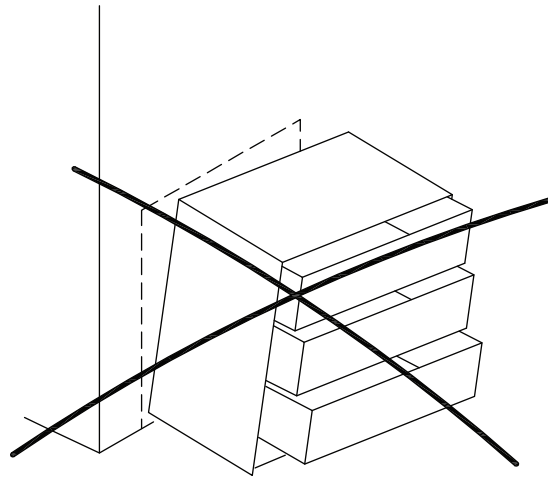
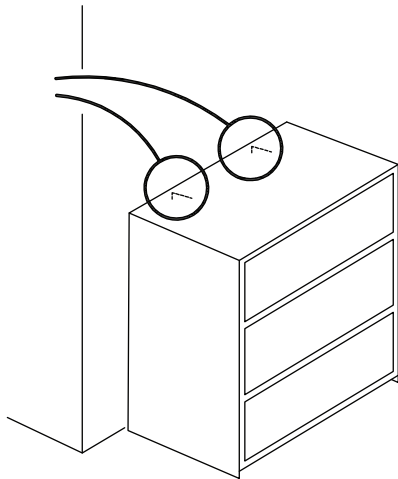

Children have died from furniture tipover. To reduce the risk of furniture tipover:

- ALWAYS install tipover restraint provided.
- NEVER put a TV on this product.
- NEVER allow children to stand, climb or hang on drawers, doors, or shelves.
- Never open more than one drawer at a time.
- Place heaviest items in the lowest drawers.

Enfants morts suite au basculement d'un meuble. Afin de limiter le risque de basculement de meuble :





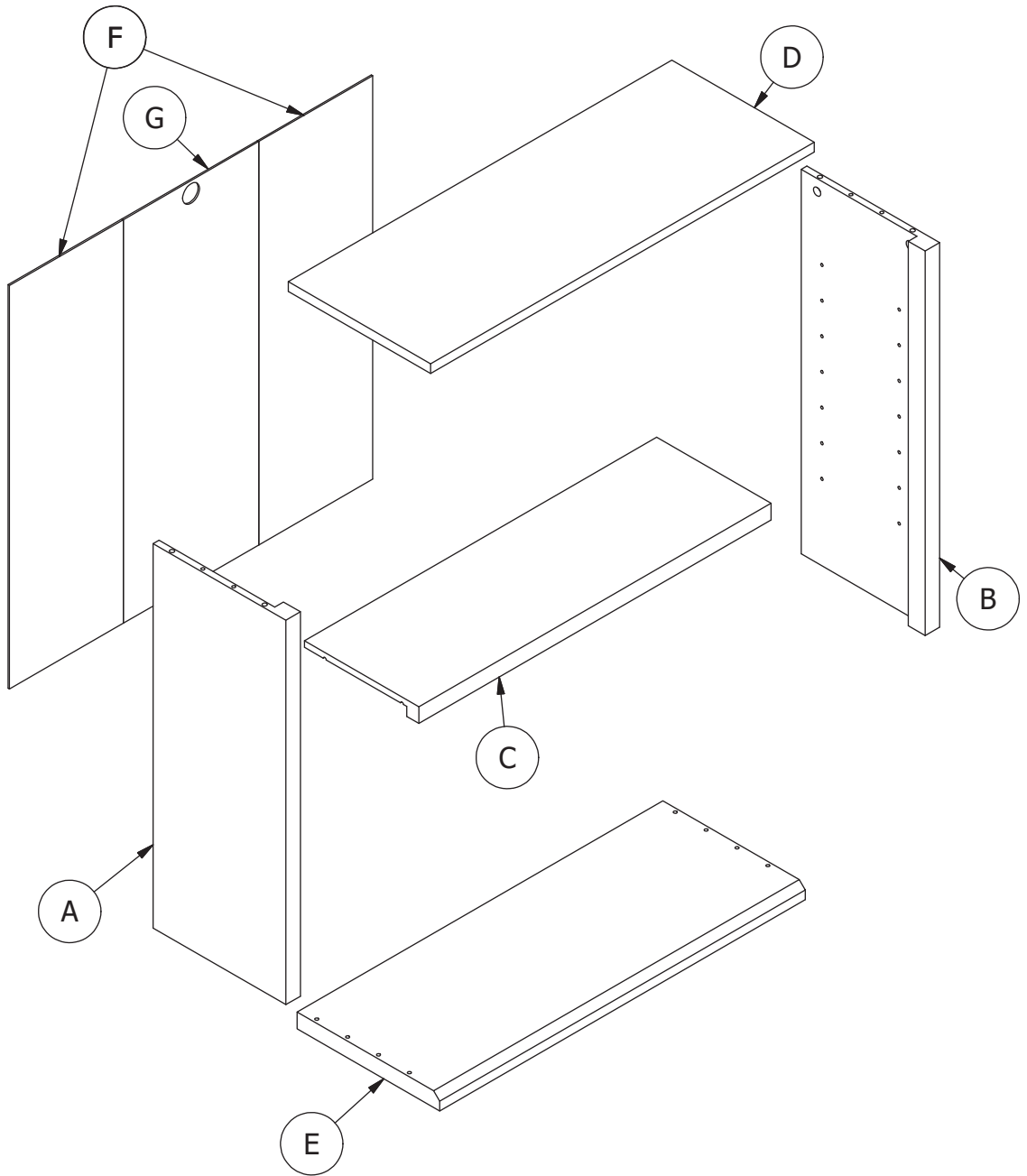

- TOUJOURS utiliser les fixations anti-basculement fournies.
- NE JAMAIS installer de TV sur ce produit.
- NE JAMAIS laisser d'enfants se tenir debout sur les tiroirs, portes ou étagères, y grimper ou s'y suspendre.
- NE JAMAIS ouvrir plus d'un tiroir à la fois.
- Placer les choses les plus lourdes dans les tiroirs du bas.

Han muerto niños por el vuelco de muebles. Para limitar el riesgo de vuelco de los muebles:

- Utilizar SIEMPRE las fijaciones antivuelco que se suministran.
- NUNCA instalar un TV sobre este producto.
- NUNCA permitir que los niños se pongan de pie, trepen o se cuelguen de los cajones, puertas o baldas.
- NUNCA abrir más de un cajón a la vez.
- Colocar los objetos más pesados en los cajones inferiores.

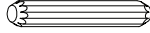



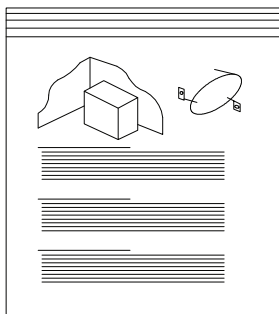

HARDWARE QUINCAILLERIE / HERRAJE

(E)	Cam Bolt	(F)	Cam Lock 15/8.5mm	(G)	Dowel Ø6 x 30mm
					
	4 units		4 units		8 units
(H)	Unitar M5 x 50mm	(I)	Nail	(J)	Floor Glide
					
	4 units		16 units		4 units
(K)	Shelf Pin				
					
	4 units				

FURNITURE TIPPING RESTRAINT SEGURO CONTRA VOLCADO DE MUEBLES DISPOSITIF DE SÉCURITÉ POUR MEUBLES



(A)	1.2 x 12 x 32 x 75mm	(B)	Flat Washer
			
	1 units		1 units
(C)	M10 x 16mm	(D)	CSK M4 x 38mm
			
	1 units		1 units

TOOLS NOT INCLUDED OUTILS PAS INCLUS / HERRAMIENTAS NO INCLUIDAS

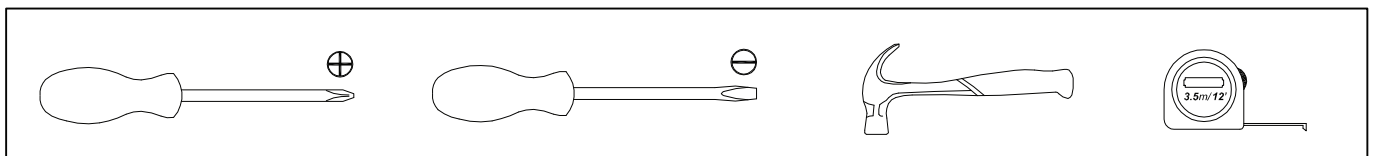

STEP 1

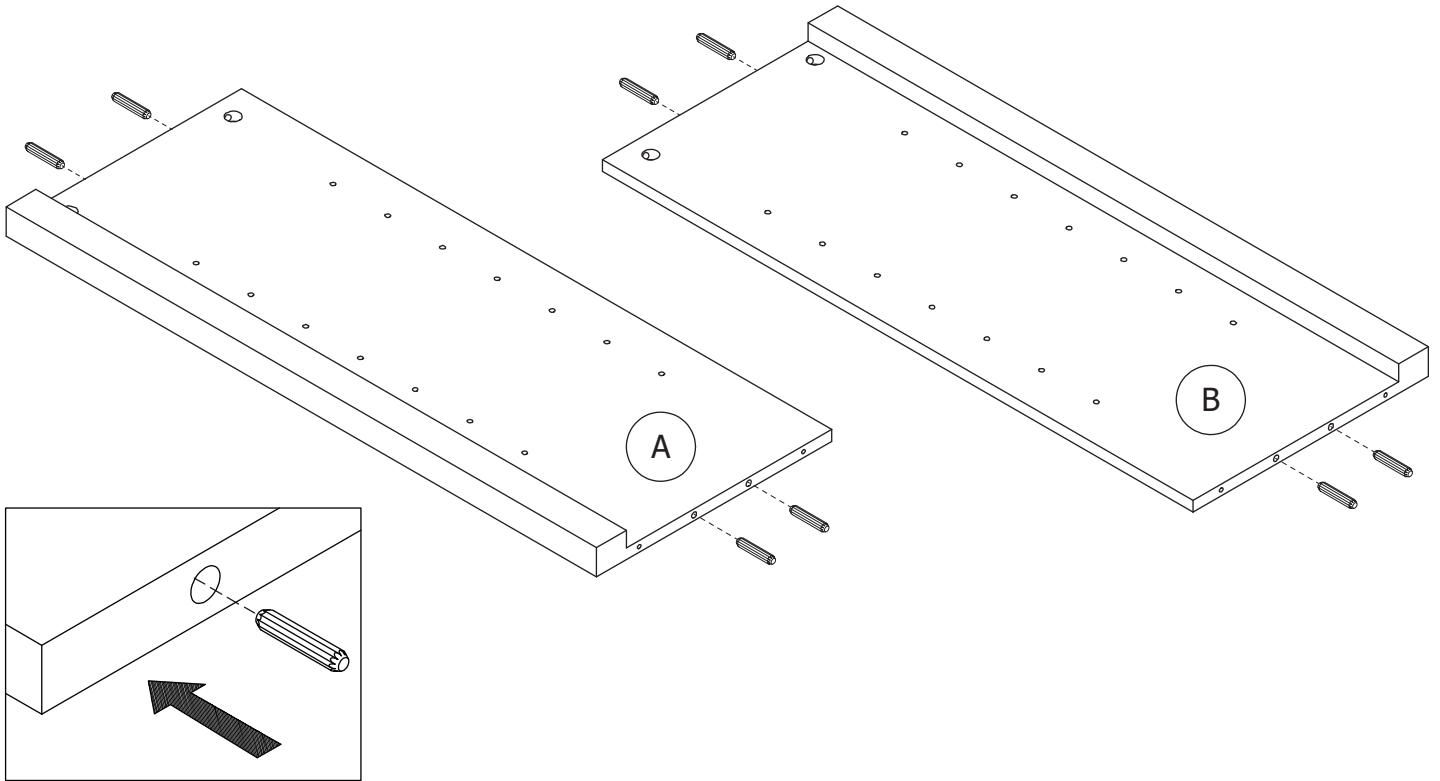
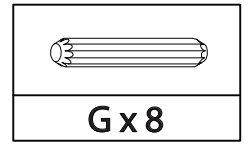

STEP 2

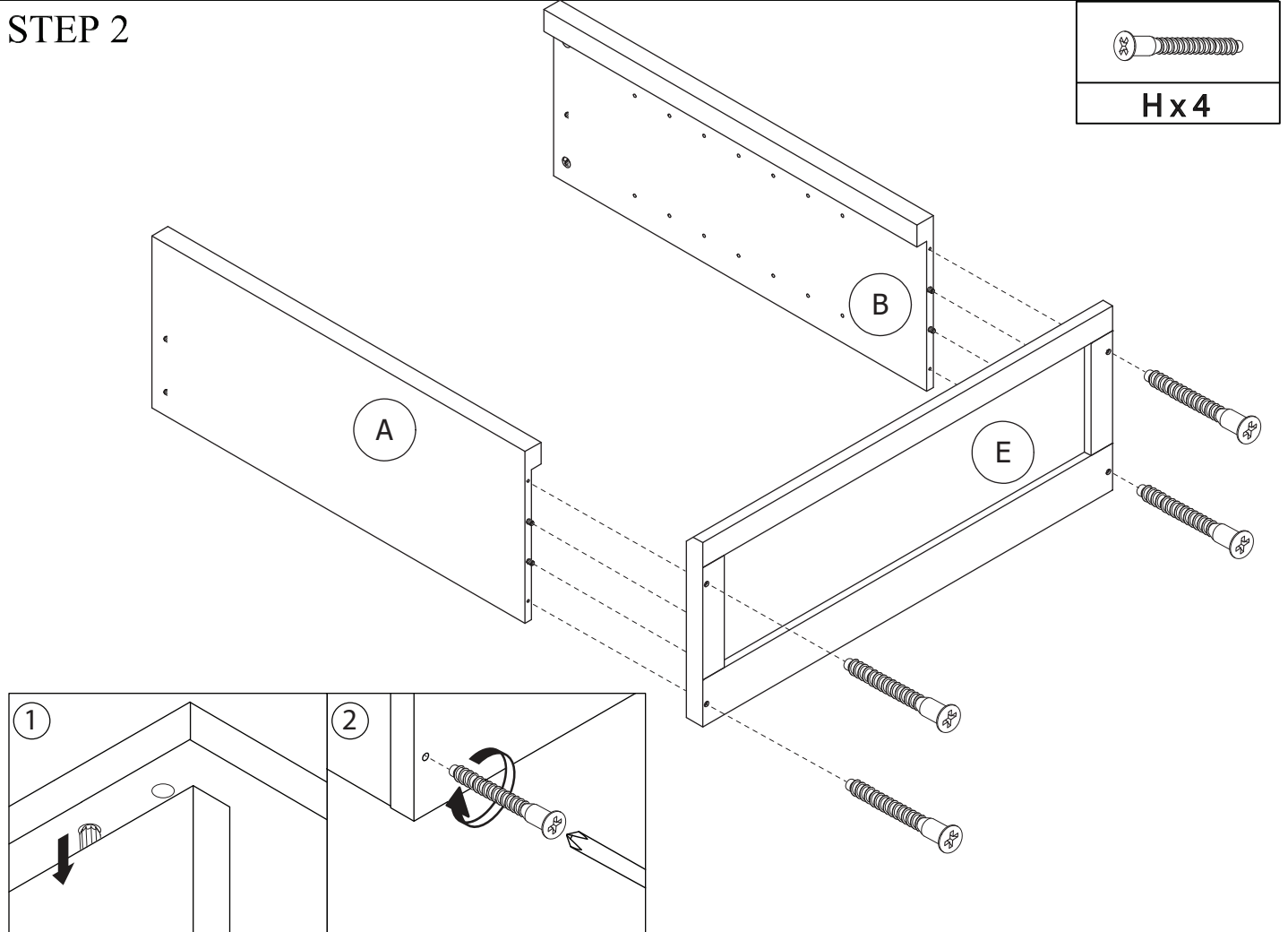
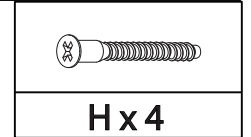

STEP 3

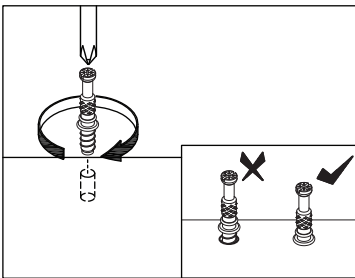
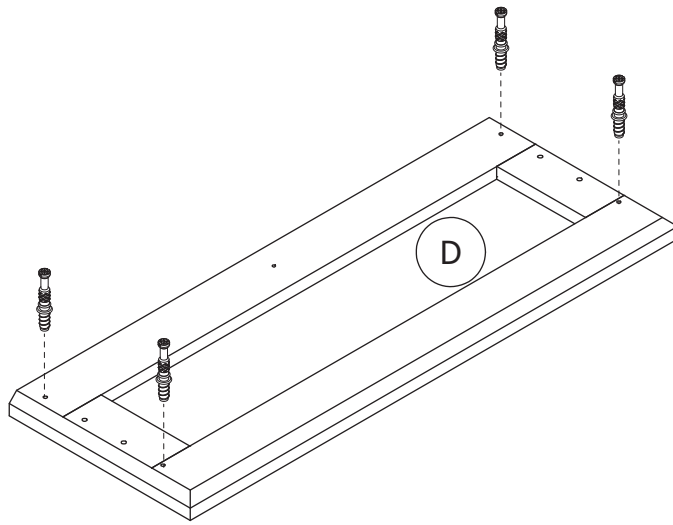
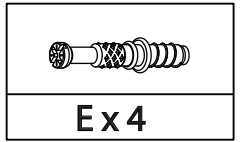

STEP 4

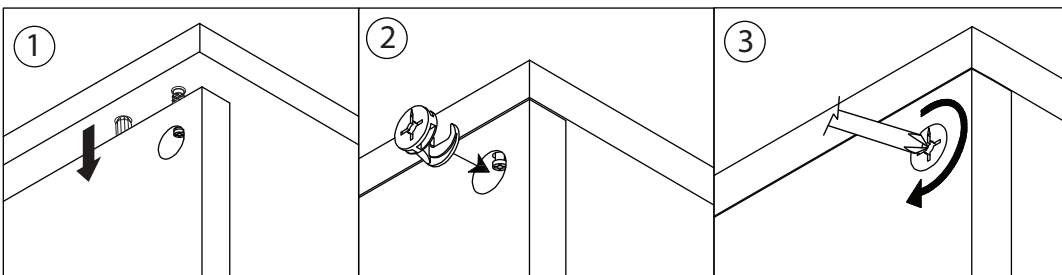
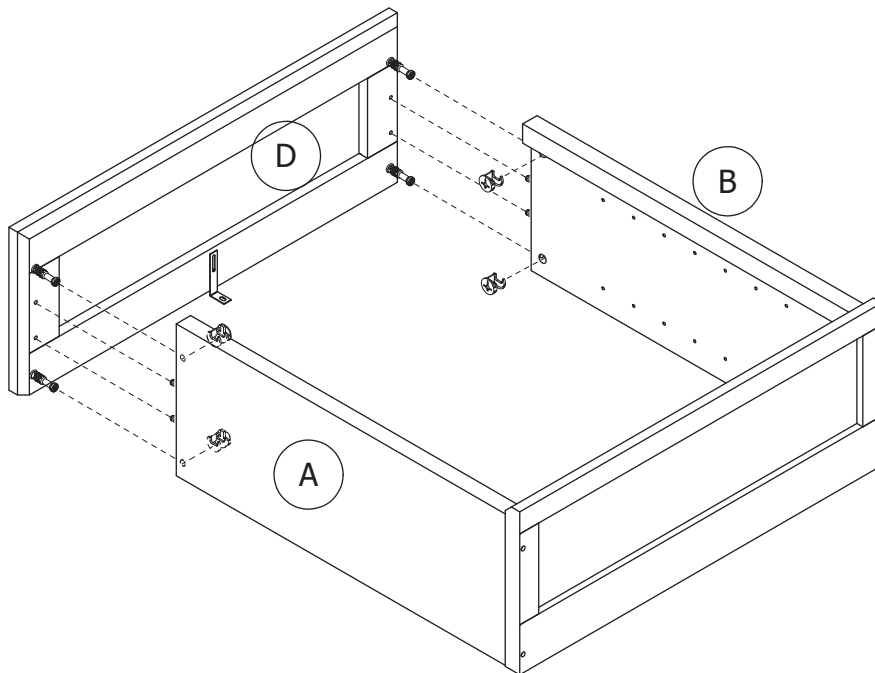
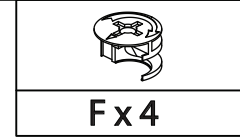

STEP 5

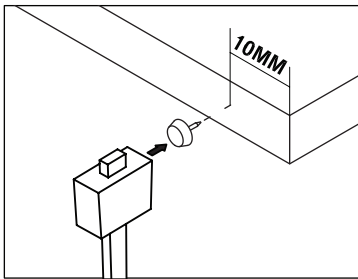
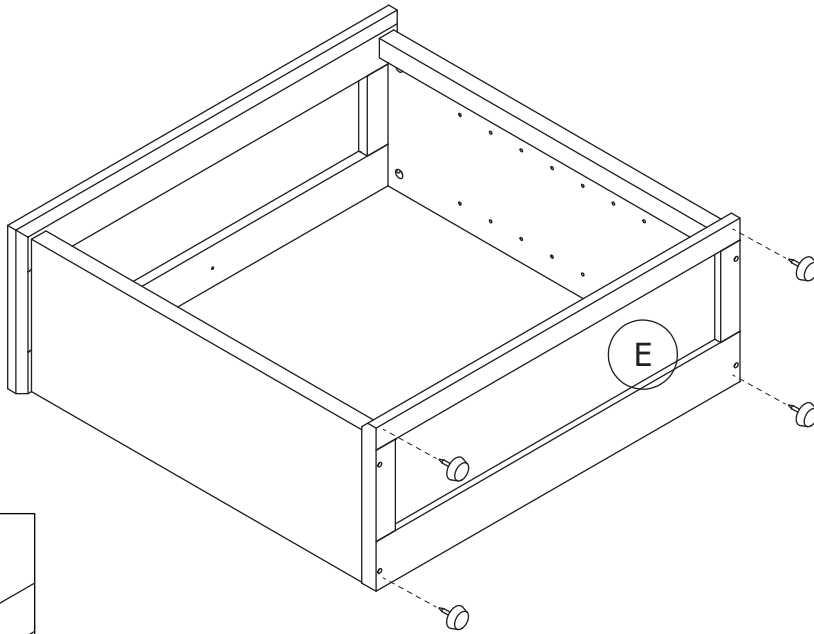
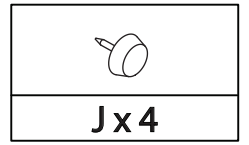

STEP 6

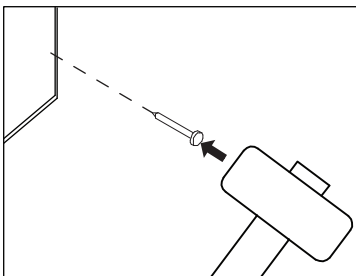
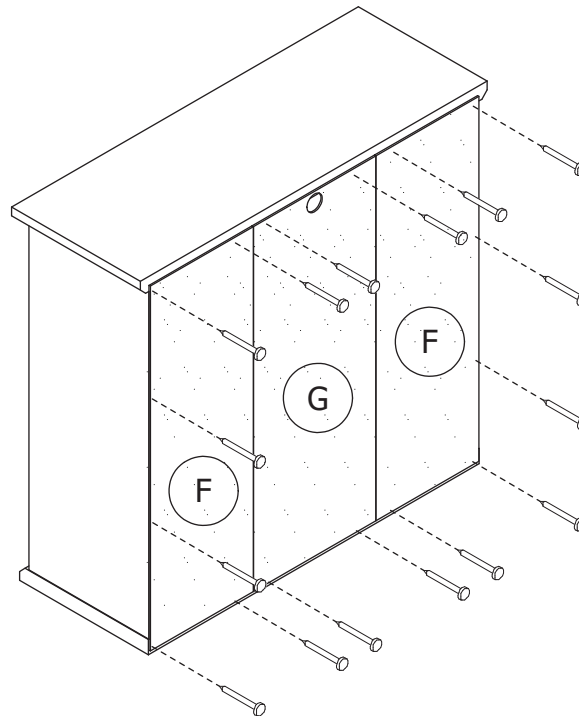
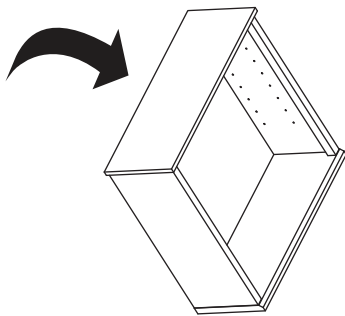
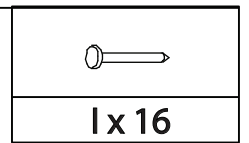

⚠ WARNING ⚠
AVERTISSEMENT / ADVERTENCIA

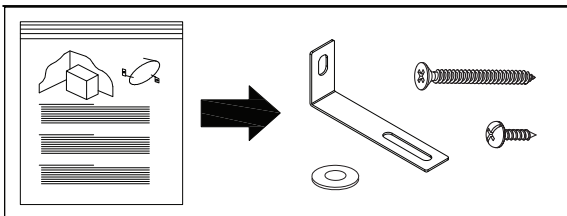
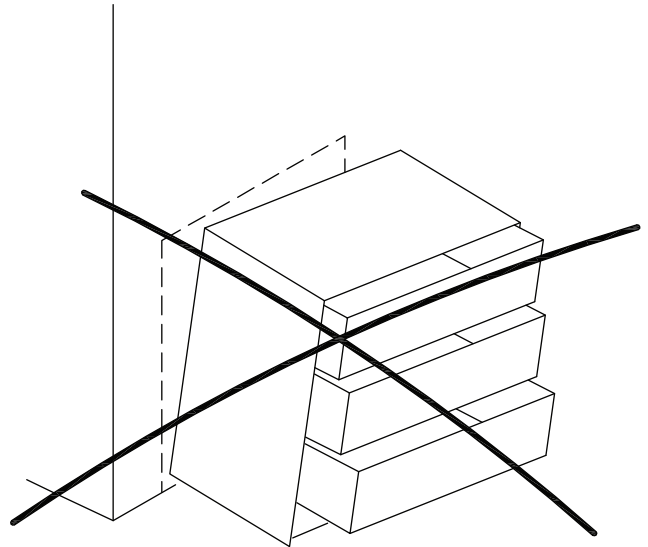
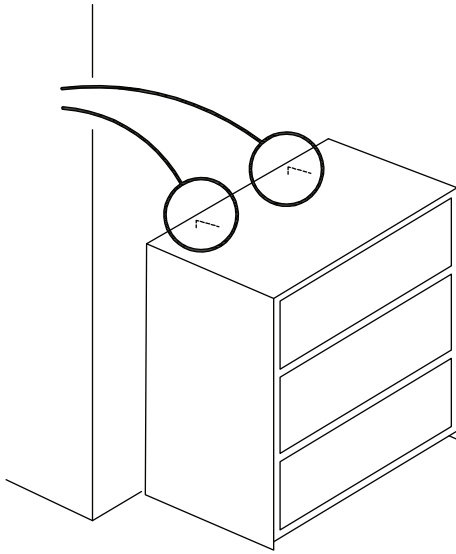

A x 1	B x 1	C x 1

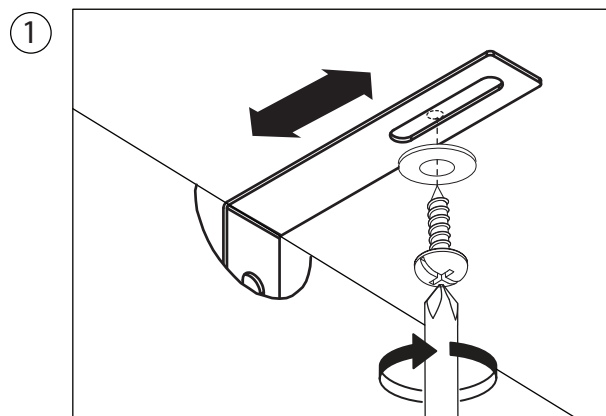
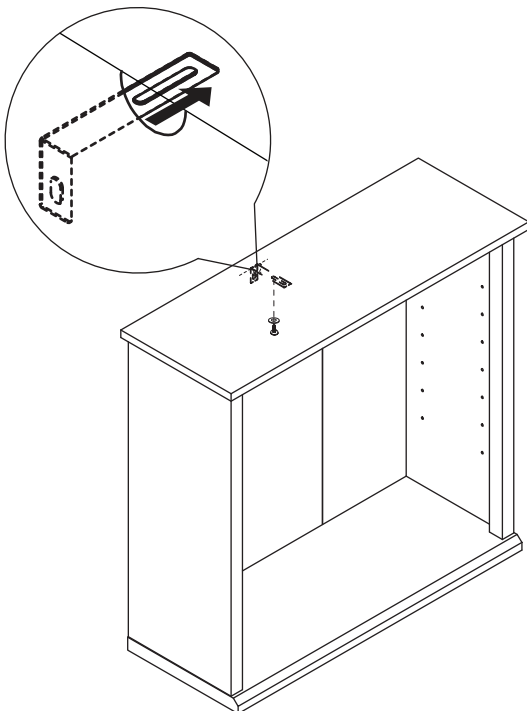

Screw the safety bracket to the furniture:

- Move the safety bracket (A) in the hole
- Screw the safety bracket (A) under the top furniture with Flat Washer (B) and Screw (C)

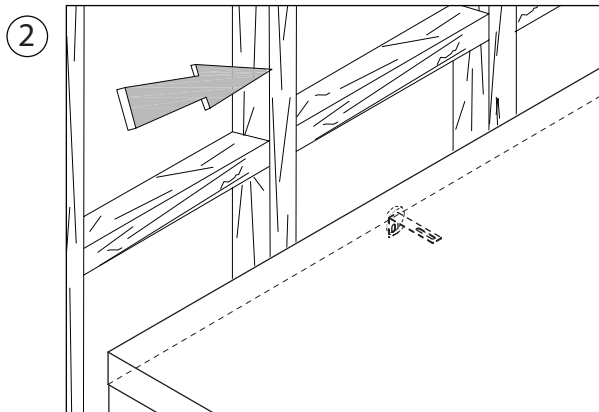
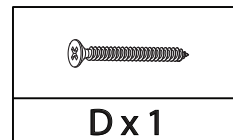

Locate a wall stud:

- Move the furniture unit to its final position to the wall
- Locate a wall stud behind the furniture unit

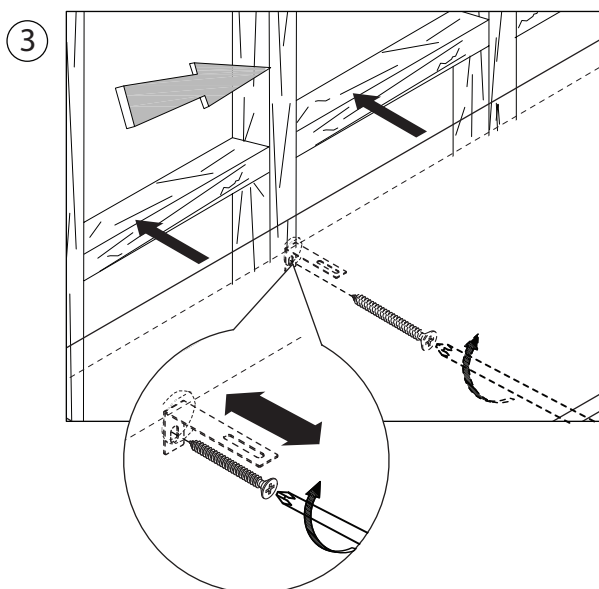

Screw the furniture to the wall stud:

- Adjust the position and screw the safety bracket (A) to the wall stud with Screw (D)

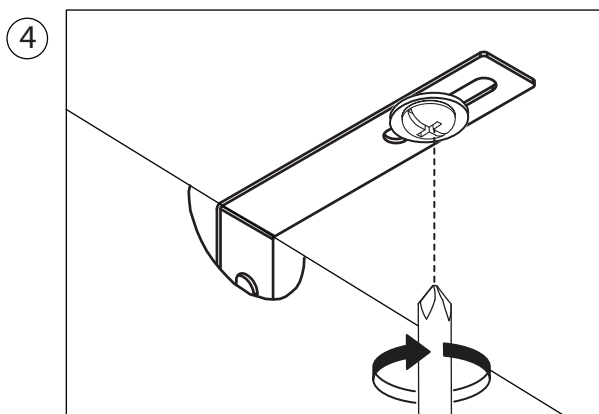

Tighten the screw:

- Tighten the screw of bracket (A) to top panel

STEP 7

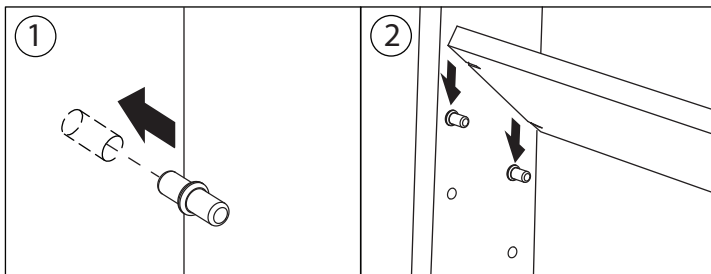
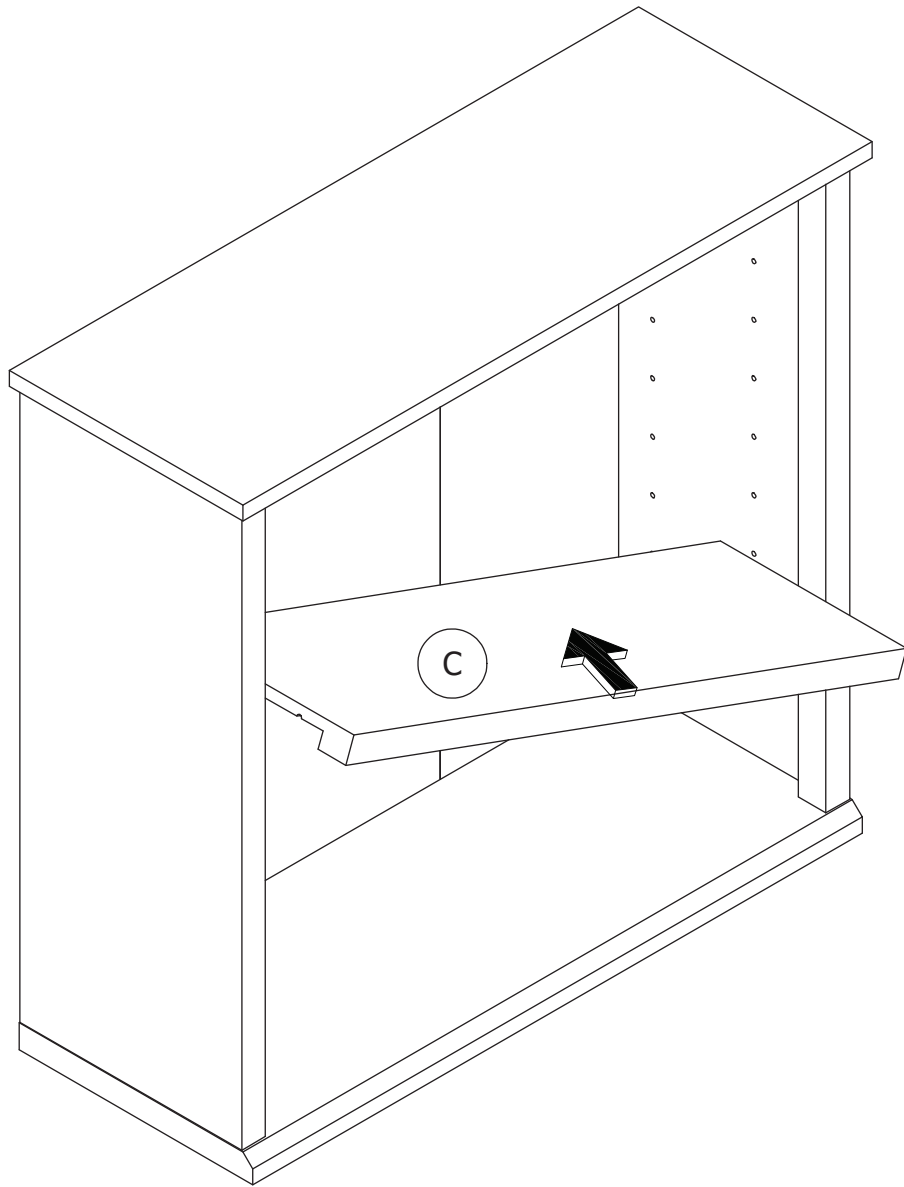
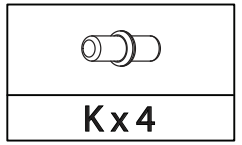

MAXIMUM LOADS CHARGES MAXIMALES / CARGA MAXIMA

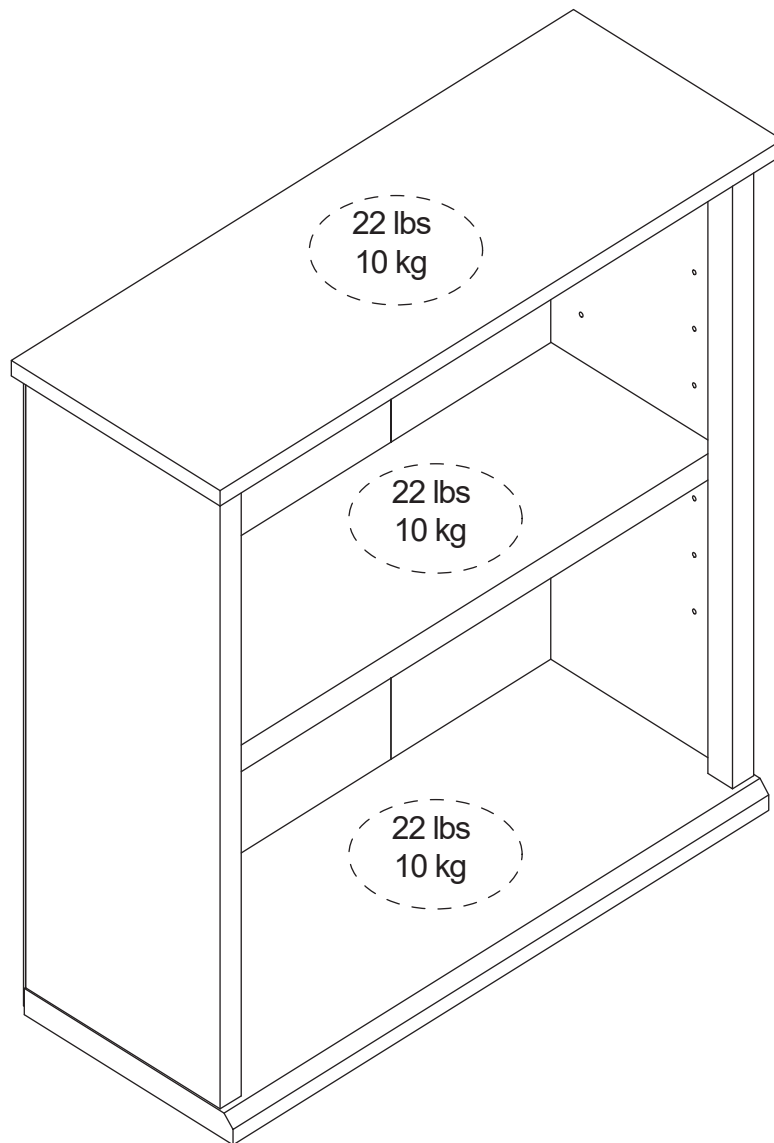

This unit has been designed to support the maximum loads shown. Exceeding these load limits could cause sagging, instability, product collapse, and/or serious injury

Ce meuble a été conçu pour supporter les charges maximales indiquées. En excédant ces limites de charge, le meuble pourrait devenir instable, s'effondrer, et/ou causer des blessures graves.

Esta unidad ha sido diseñada para soportar la carga máxima anotada. El exceder estos límites puede causar inestabilidad, colapsarse y/o causar serias lesiones
