



we furnish fun.

ASSEMBLY INSTRUCTIONS

POKER TABLE

LOOSELY ATTACH EACH SCREW UNTIL FRAME IS ASSEMBLED THEN TIGHTEN WHEN COMPLETE

STEP 1

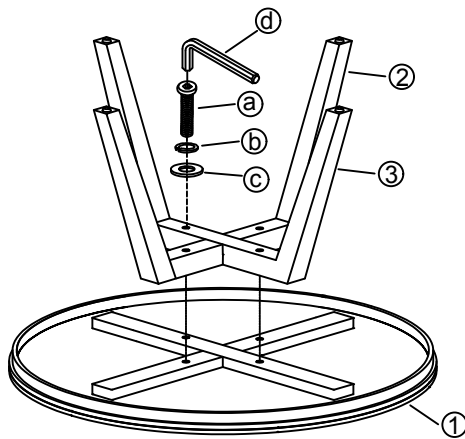

Attach the bottom legs 2 & 3 (02&03) to the table top (01).

STEP 2

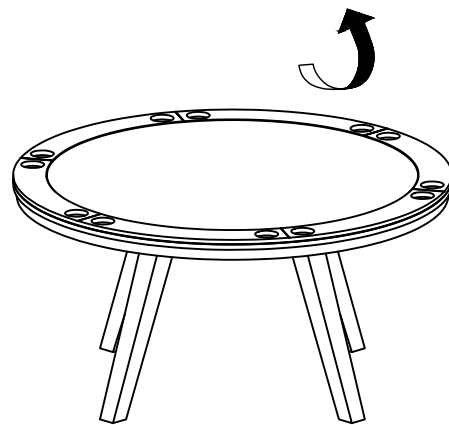

Assembly is completed

List of Part For 1 Set

Code	Figure	Part	Q'ty.
①		Table Top	1
②		Bottom leg	1
③		Bottom leg	1

List of Part For 1 Set

Code	Figure	Hardware	Q'ty.
Ⓐ		JCBC Bolt 5/16"*3-1/2"	4
Ⓑ		Spring Washers 5/16"	4
Ⓒ		Washers 5/16"	4
Ⓓ		Allen Key	1

THANK YOU FOR YOUR PURCHASE

MADE IN CHINA