

# Owner's Manual

## OUTDOOR PATIO HEATER

STD

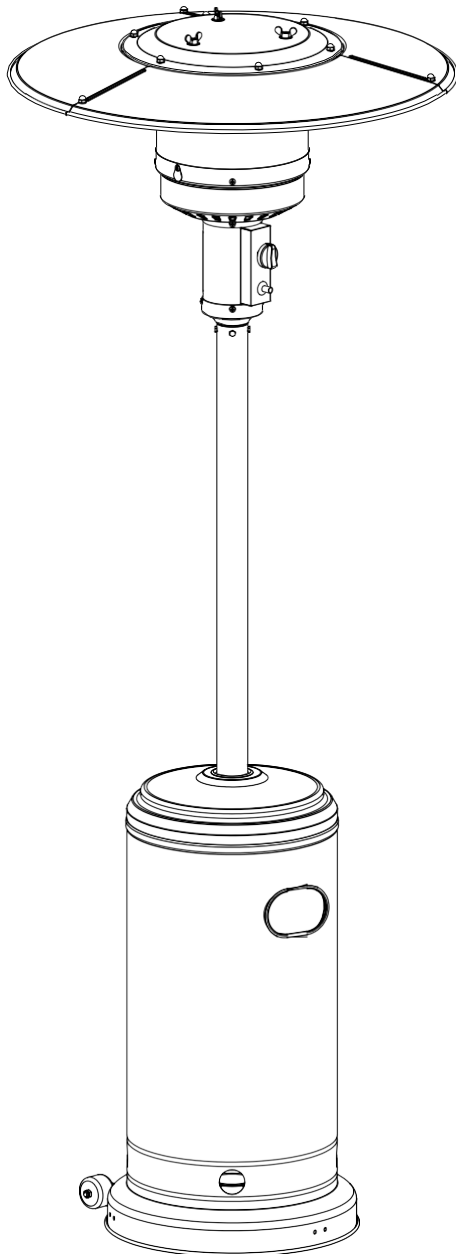

### **⚠ DANGER**

If you smell gas:

1. Shut off gas to the appliance.
2. Extinguish any open flame.
3. If odor continues, keep away from the appliance and immediately call your gas supplier or fire department.

### **⚠ WARNING**

Do not store or use gasoline or other flammable vapors and liquids in the vicinity of this or any other appliance. An LP-cylinder not connected for use shall not be stored in the vicinity of this or any other appliance.

### **⚠ WARNING: For Outdoor Use Only**

#### **⚠ DANGER**



#### **CARBON MONOXIDE HAZARD**

This appliance can produce carbon monoxide which has no odor.

Using it in an enclosed space can kill you.

Never use this appliance in an enclosed space such as a camper, tent, car or home.

### **⚠ WARNING**

Improper installation, adjustment, alteration, service or maintenance can cause property damage, injury or death. Read the installation, operation and maintenance instructions thoroughly before installing or servicing this equipment.

ANSI STD Z83.26-2014--CSA STD 2.37-2014 Gas-fired outdoor infrared patio heaters

Customer Service Email: [CustomerExperience@belnickinc.com](mailto:CustomerExperience@belnickinc.com) | Phone: 866-552-2810  
NAN-HSS-AGH-BR-GG

# PACKAGE CONTENTS

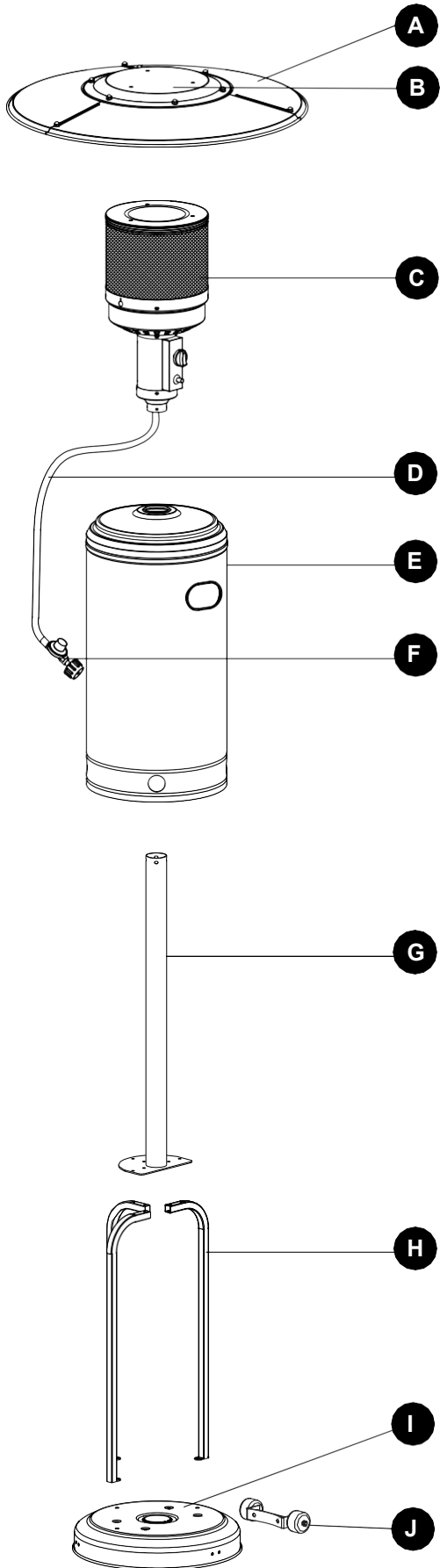

PART	DESCRIPTION	QUANTITY
A	Reflector Panel	3
B	Reflector Plate	1
C	Head Assembly	1
D	Gas Hose	1
E	Cylinder Housing	1
F	Regulator	1
G	Post	1
H	Support Bracket	3
I	Base	1
J	Wheel Kit	1

## HARDWARE CONTENTS (shown actual size)



**AA** (AA & BB)  
Included in  
wheel kit  
**M8  
Flange  
nut**  
Qty. 2

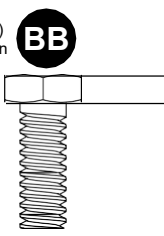

**BB**  
**Bolt**  
M8 x 15  
Qty. 5

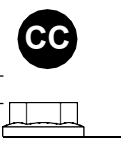

**CC**  
**M6  
Flange  
nut**  
Qty. 6

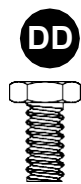

**DD**  
**Stainless  
steel bolt**  
Qty. 4  
Preassembled  
on burner head

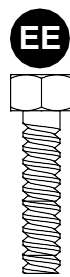

**EE**  
**Bolt**  
M6 x 30  
Qty. 6

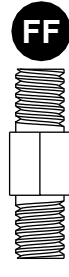

**FF**  
**Reflector  
spacer**  
Qty. 3

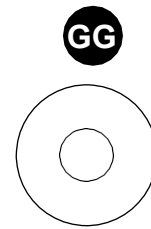

**GG**  
**Washer**  
Qty. 9



**II**  
**Screw**  
M6 X 8  
Qty. 9

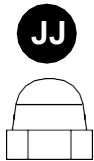

**JJ**  
**Cap nut**  
Qty. 9

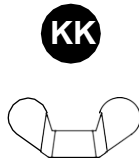

**KK**  
**Wing nut**  
Qty. 3

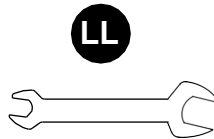

**LL**  
**Wrench**  
Qty. 1  
(not actual  
size)

### Note:

1. Four stainless steel bolts (Part DD) are preassembled on the head assembly.
2. Two M8 bolts (BB) and two M8 nuts (AA) are packed with the wheel kit.

## SAFETY INFORMATION

Please read and understand this entire manual before attempting to assemble, operate or install the product. This manual contains important information about the assembly, operation and maintenance of this patio heater. General safety information is presented in these first few pages and is also located throughout the manual. Keep this manual for future reference and to educate new users of this product. This manual should be read in conjunction with the labeling on the product. Safety precautions are essential when any mechanical or propane fueled equipment is involved. These precautions are necessary when using, storing, and servicing. Using this equipment with the respect and caution demanded will reduce the possibilities of personal injury or property damage. The following symbols shown below are used extensively throughout this manual. Always heed these precautions, as they are essential when using any mechanical or fueled equipment.

### DANGER

DANGER indicates an imminently hazardous situation which, if not avoided, will result in death or serious injury.

### DANGER

Failure to comply with the precautions and instructions provided with this heater can result in death, serious bodily injury and property loss or damage from hazards of fire, explosion, burn, asphyxiation, and/or carbon monoxide poisoning. Only persons who can understand and follow the instructions should use or service this heater.

### DANGER

#### FOR YOUR SAFETY

If you smell gas:

1. Shut off gas to the appliance.
2. Extinguish any open flame.
3. If odor continues, keep away from the appliance and immediately call your gas supplier or fire department.

## SAFETY INFORMATION

### DANGER

- EXPLOSION - FIRE HAZARD
- Keep solid combustibles, such as building materials, paper or cardboard, a safe distance away from the heater as recommended by the instructions.
- Provide adequate clearances around air openings into the combustion chamber.
- Never use the heater in spaces which do or may contain volatile or airborne combustibles, or products such as gasoline, solvents, paint thinner, dust particles or unknown chemicals.
- During operation, this product can be a source of ignition. Keep heater area clear and free from combustible materials, gasoline, paint thinner, cleaning solvents and other flammable vapors and liquids. Do not use heater in areas with high dust content. Minimum heater clearances from combustible materials: three (3) feet from the sides & three (3) feet from the top.

### DANGER

- EXPLOSION - FIRE HAZARD
- Never store propane near high heat, openflames, pilot lights, direct sunlight, other ignition sources or where temperatures exceed 120 degrees F (49°C).
- Propane vapors are heavier than air and can accumulate in low places. If you smell gas, leave the area immediately.
- Never install or remove propane cylinder while heater is lighted, near flame, pilot lights, other ignition sources or while heater is hot to touch.
- This heater is red hot during use and can ignite flammables too close to the burner. Keep flammables at least 3 feet from sides & 3 feet from top. Keep gasoline and other flammable liquids and vapors well away from heater.
- Store the propane cylinder outdoors in a well ventilated space out of reach of children. Never store the propane cylinder in an enclosed area (house, garage, etc.). If heater is to be stored indoors, disconnect the propane cylinder for outdoor storage.

### WARNING

We cannot foresee every use which may be made of our heaters. Check with your local fire safety authority if you have questions about heater use. Other standards govern the use of fuel gases and heat producing products for specific uses. Your local authorities can advise you about these. If no local codes exist, follow National Fuel Gas Code, ANS Z223.1. In Canada, installation must conform to local codes. If no local codes exist, follow the current National standards of CANADA CAN/CGA-B 149.2.

### DANGER

- CARBON MONOXIDE HAZARD
- This heater is a combustion appliance. All combustion appliances produce carbon monoxide (CO) during the combustion process. This product is designed to produce extremely minute, non-hazardous amounts of CO if used and maintained in accordance with all warnings and instructions. Do not block air flow into or out of the heater.
- Carbon Monoxide (CO) poisoning produces flu-like symptoms, watery eyes, headaches, dizziness, fatigue and possibly death. You can't see it and you can't smell it. It's an invisible killer. If these symptoms are present during operation of this product get fresh air immediately!
- For outdoor use only.
- Never use inside house, or other unventilated or enclosed areas.
- This heater consumes air (oxygen). Do not use in unventilated or enclosed areas to avoid endangering your life.

### WARNING

WARNING indicates an imminently hazardous situation which, if not avoided, will result in death or serious injury.

### WARNING

Do not store or use gasoline or other flammable vapors and liquids in the vicinity of this or any other appliance. An LP (Liquid Propane) cylinder not connected for use shall not be stored in the vicinity of this or any other appliance.

### WARNING:



DANGER



**CARBON MONOXIDE HAZARD**  
This appliance can produce carbon monoxide which has no odor. Using it in an enclosed space can kill you. Never use this appliance in an enclosed space such as a camper, tent, car or home.

### WARNING

Improper installation, adjustment, alteration, service or maintenance can cause property damage, injury or death. Read the installation, operation and maintenance instructions thoroughly before installing or servicing this equipment.

## SAFETY INFORMATION

### WARNING

California Proposition 65  
Combustion by-products produced when using this product contain chemicals known to the State of California to cause cancer, birth defects, and other reproductive harm.

### WARNING

#### BURN HAZARD

- Never leave heater unattended when hot or in use.
- Keep out of reach of children.

### WARNING

Certain materials or items, when stored under the heater, will be subjected to radiant heat and could be seriously damaged.

### CAUTION

#### SERVICE SAFETY

- Keep all connections and fittings clean. Make sure propane cylinder valve outlet is clean.
- During set up, check all connections and fittings for leaks using soapy water. Never use a flame.
- Use as a heating appliance only. Never alter in any way or use with any device.

### CAUTION

CAUTION indicates an imminently hazardous situation which, if not avoided, may result in minor or moderate personal injury, or property damage.

### WARNING

- This product is fueled by propane gas. Propane gas is invisible, odorless, and flammable. An odorant is normally added to help detect leaks and can be described as a “rotten egg” smell. The odorant can fade over time so leaking gas is not always detectable by smell alone.
- Propane gas is heavier than air and leaking propane will sink to the lowest level possible. It can ignite by ignition sources including matches, lighters, sparks or open flames of any kind many feet away from the original leak. Use only propane gas set up for vapor withdrawal.
- Store or use propane gas in compliance with local ordinances and codes or with ANS/NFPA 58. Turnoff propane when not in use.

### WARNING

- Alert children and adults to the hazards of high surface temperatures. Stay away from these surfaces to avoid burning skin or igniting clothing.
- Carefully supervise young children when in the vicinity of the heater.
- Do not hang clothing or any other flammable materials from the heater, or place on or near the heater.
- Replace any guard or protective device removed for servicing the appliance prior to placing back in service.
- Installation and repair should be done by a qualified service person. The heater should be inspected before use and annually by a qualified serviceperson. More frequent cleaning may be required as necessary. It is imperative that the control compartment, burners, and circulating air passageway of the appliance be kept clean.

## PREPARATION

Before beginning assembly of product, make sure all parts are present. Compare parts with package contents list and hardware contents above. If any part is missing or damaged, do not attempt to assemble the product. Contact customer service for replacement parts.

**The use of LP in this user manual stands for Liquid Propane.**

**Estimated Assembly Time: 60 minutes**

Tools Required for Assembly (not included):

Phillips screwdriver w/ medium blade; Two  $\frac{3}{4}$ " Wrenches; Leak Detection Solution.

## ASSEMBLY INSTRUCTIONS

1. Attach wheel assembly (J) to base (I). Line up holes in wheel bracket with corresponding holes in base, insert two bolts M8 x 15 (BB) through holes, and finger tighten two M8 flange nuts (AA). Be sure that the wheel assembly is parallel to the base, and fully tighten bolts.

### Hardware Used

**AA** M8 Flange nut  x 2

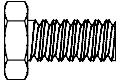
**BB** Bolt M8 x 15  x 2

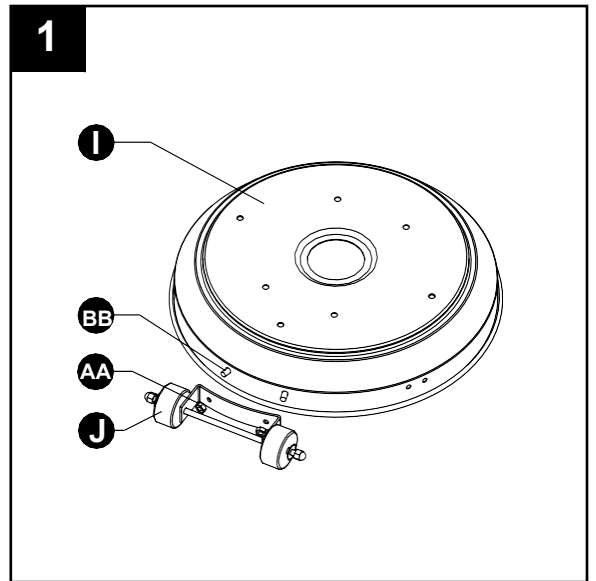

2. Attach three support brackets (H) loosely to base with three bolts M8 x 15 (BB) downward through support brackets into the Base.

### Hardware Used

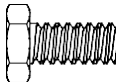
**BB** Bolt M8 x 15  x 3

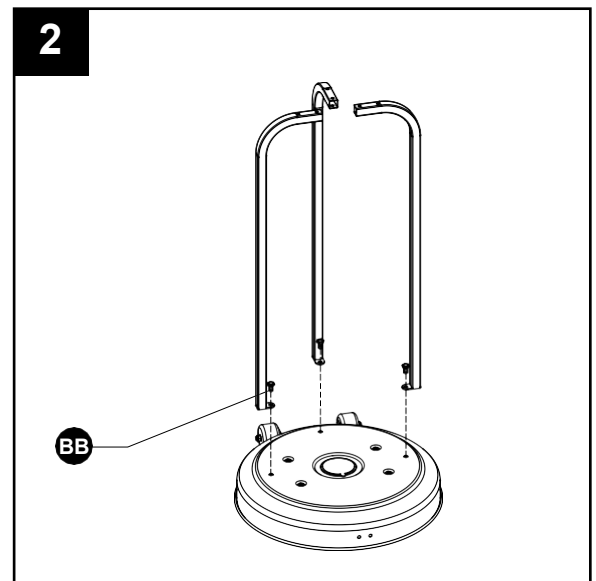

3. Install post (G) onto three support brackets (H). Attach post to support brackets using six bolts M6 x 30 & six M6 flange nuts. Fully tighten all of the screws.

### Hardware Used

**CC** M6 Flange nut  x 6

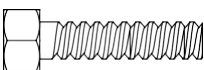
**EE** Bolt M6 x 30  x 6

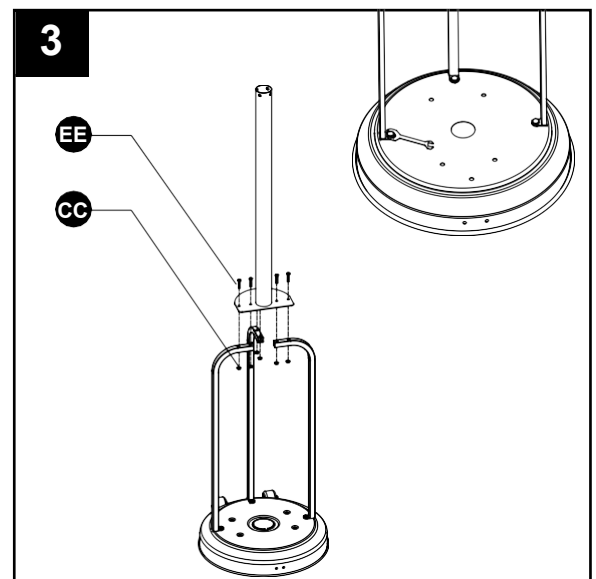

## ASSEMBLY INSTRUCTIONS

4. Connect the gas hose to the connector of head assembly (See Included One Page Assembly Instructions)

**Note: You will need two 3/4" wrenches to make a secure connection**

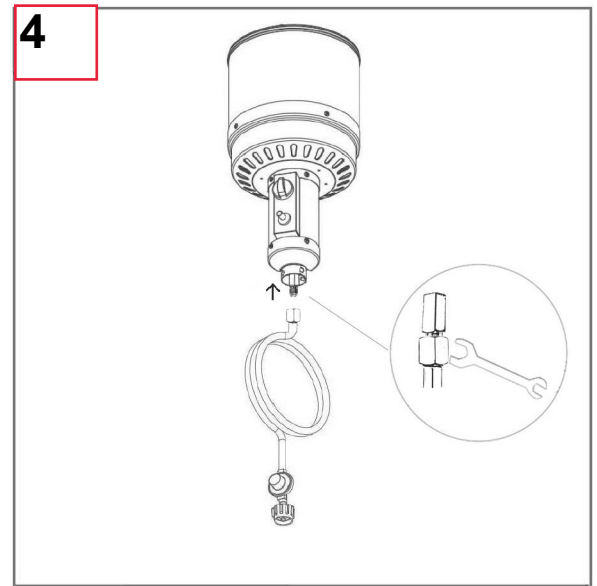

A. **NOTE:** Perform a leak check before completely assembling: Connect the nut of gas regulator to the LP cylinder. Brush a half-and-half solution of liquid soap and water onto the connection.

**DO NOT** turn on the heater, just turn LP cylinder valve on. If bubbles appear, it indicates a gas leak.

**Note: It is necessary to do a leak check here before completing assembly or operation! (Turn to page 12 for more detailed reference)**

**After checking, do not forget to turn off the LP cylinder valve and disconnect the regulator to continue assembly steps.**

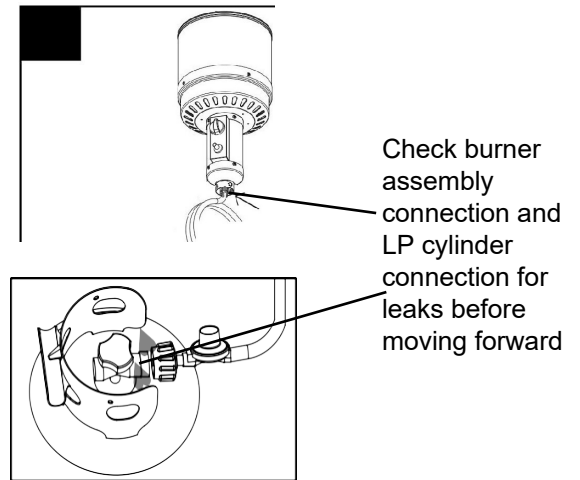

5. Load Cylinder Housing (E) onto Post(G). Slide Cylinder Housing down.

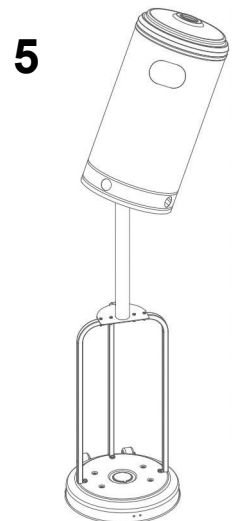

6. Attach reflector spacers (FF) and three washers (GG) to screen cover. Tighten the reflector spacers. Unscrew four stainless steel bolts (DD) which were preassembled on the head assembly.

#### Hardware Used

**ff** Reflector Space x 3

**gg** Washer 8 x 3

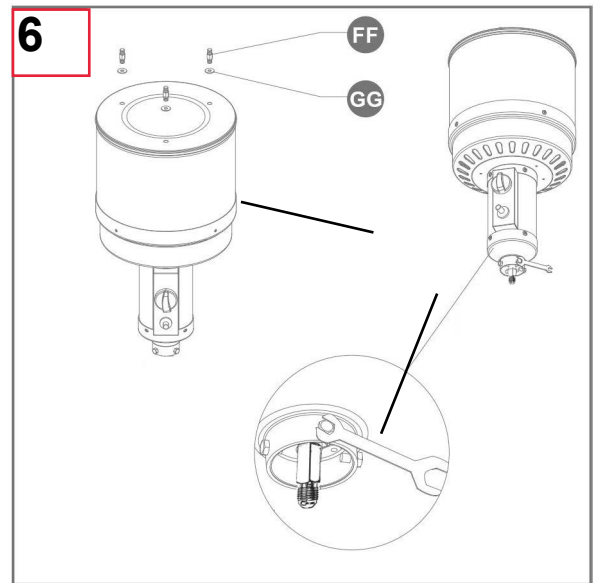

7. Load head assembly by inserting hose into post. Insert head assembly into post. Attach head assembly to post, and loosely install four stainless steel bolts. Tighten bolts securely.

**Note: The control knob on head assembly should be above the decal on post. When applicable, visually check all portions of the hose assembly located within the confines of the heater post.**

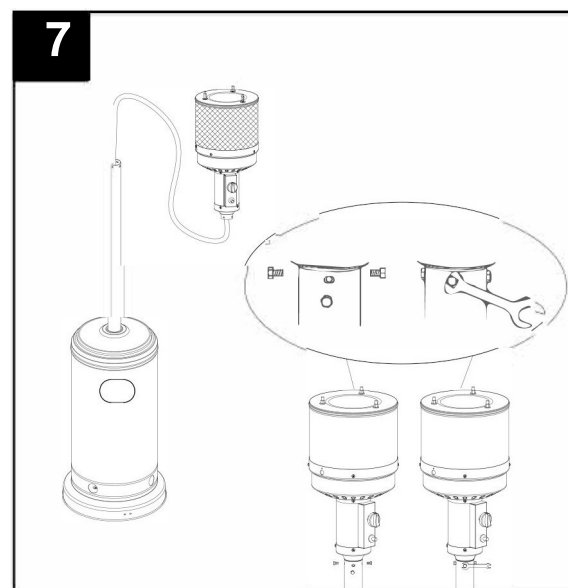

## ASSEMBLY INSTRUCTIONS

**8. WARNING: Peel off protective plastic layer before assembling.**

*Note: For proper alignment of reflector sections, loosen each bolt prior to further assembly and tighten after sections are aligned.*

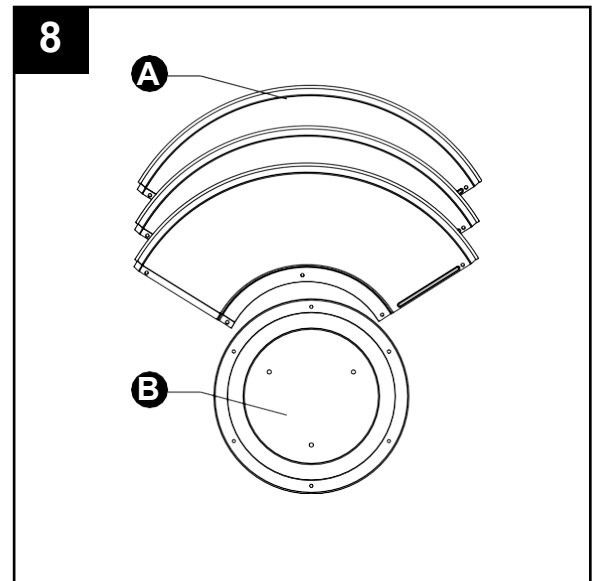

**9.** Slide two reflector panels (A) together. Insert one screw M6 X 8 and screw on cap nut (JJ) loosely.

### Hardware Used

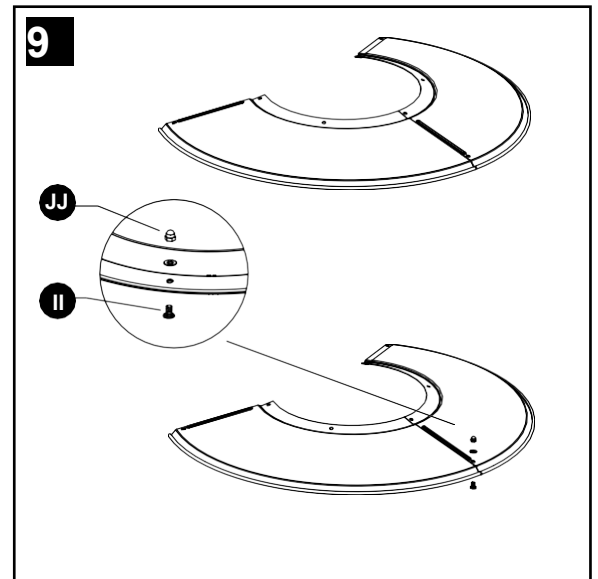
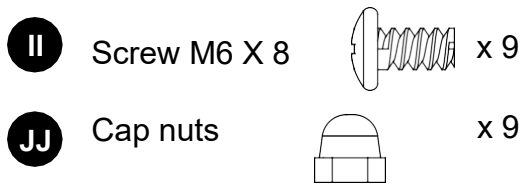

**10.** Slide reflector plate (B) onto reflector panels. Insert one screw M6 X 8 (II) and screw on cap nut (JJ) loosely. Repeat procedure to complete the assembly of all four sections. Fully tighten all of the screws in the rolled edge.

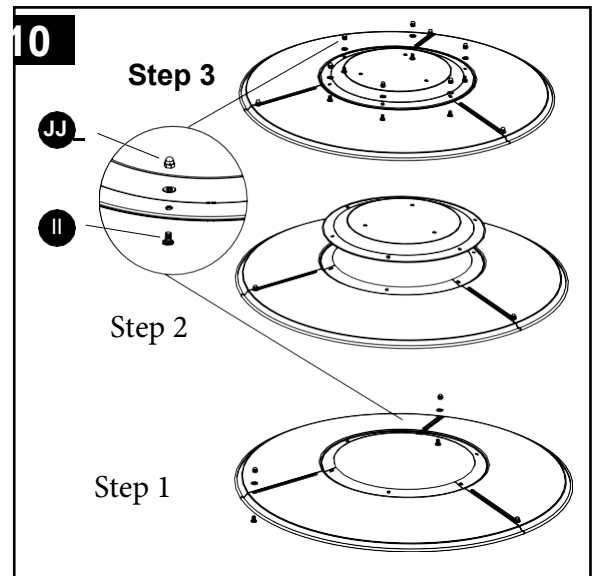

## ASSEMBLY INSTRUCTIONS

**11.** Support heater. Slide three washers (GG) over threaded end of spacer. Locate reflector assembly on 3 spacers. Install three washers on spacers and securely tighten wing nuts (KK) but do not over tighten.

### Hardware Used

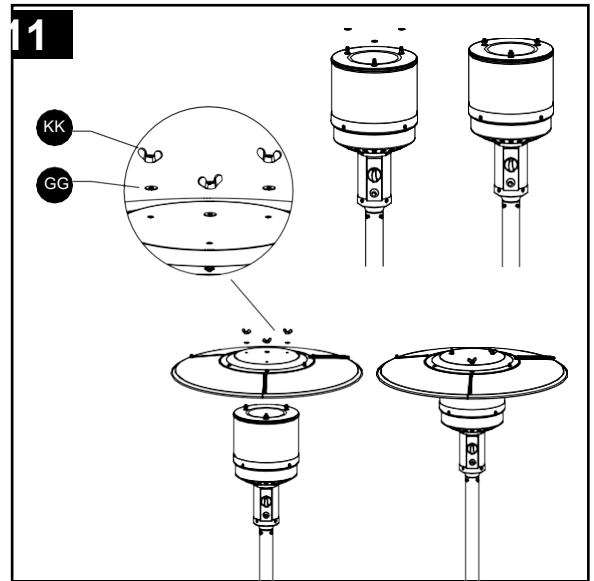
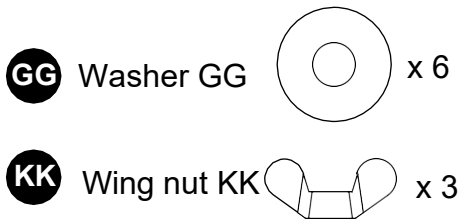

**12.** Connect gas regulator to cylinder.  
The propane gas and cylinder are sold separately.

Every part of the heater shall be secure against displacement and shall be constructed to maintain a fixed relationship between essential parts under normal and reasonable conditions of handling and usage. Parts not permanently secured shall be designed so they cannot be incorrectly assembled and cannot be improperly located or misaligned in removing or replacing during cleaning or other servicing.

Use a standard 20 lb. propane cylinder only (approximately 12.2 in. / 31cm. in diameter and 17.9 in. / 45.5cm high).

Use this heater only with a propane vapor withdrawal supply system. See chapter 5 of the standard for storage and handling of liquefied petroleum gas, ANS/NFPA 58. Your local library or fire department should have this book.

Storage of an appliance indoors is permissible only if the cylinder is disconnected and removed from the appliance. A cylinder must be stored outdoors in a well-ventilated area out of the reach of children. A disconnected cylinder must have dust caps tightly installed and must not be stored in a building, garage or any other enclosed area. The maximum inlet gas supply pressure: 250 psi /1750 kPa. The minimum inlet gas supply pressure: 25 psi /175 kPa. Manifold pressure with regulator provided: 11 inch W.C/ 2.74 kPa. The pressure regulator and hose assembly supplied with the appliance must be used. The installation must conform with local codes, or in the absence of local codes, with national fuel gas code, ANS Z223.1/NFPA54, natural gas and propane Installation Code, CSA B149.1, or propane storage and handling code, B149.2.

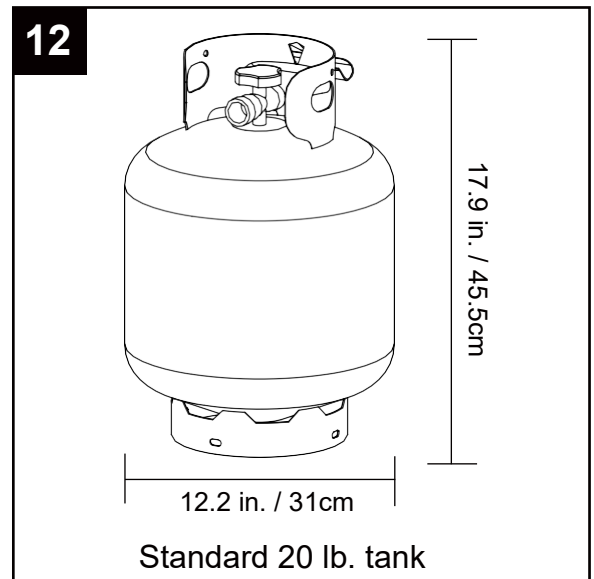

## ASSEMBLY INSTRUCTIONS

The knob on the LP tank must be closed. Make sure that the knob is turned ↻ clockwise to a full stop. The cylinder supply system must be arranged for vapor withdrawal. Check that the control knob on the control unit is turned off. Hold the regulator in one hand and insert the nipple into the valve outlet. Be sure the nipple is centered in the valve outlet. The coupling nut connects to the large outside threads on the valve outlet. Hand-tighten the coupling nut ↻ clockwise until it comes to a full stop. Firmly tighten by hand only.

**To Disconnect:** Ensure LP tank valve is closed by turning ↻ clockwise. Turn the coupling nut ↻ counterclockwise until the regulator assembly detaches.

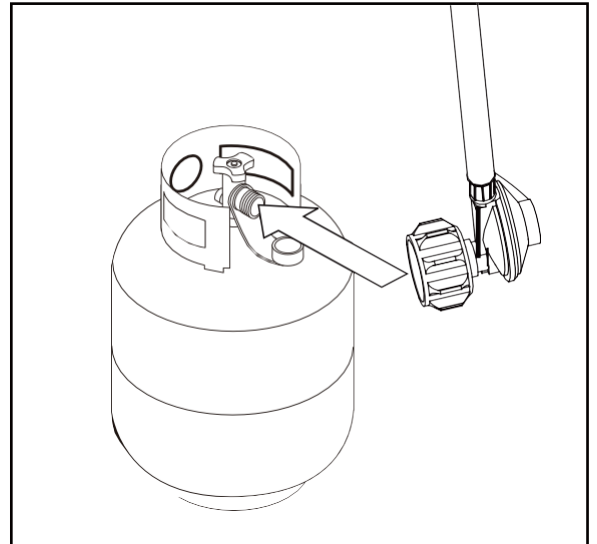

A dented, rusted or damaged propane cylinder may be hazardous and should be checked by your cylinder supplier. Never use a propane cylinder with a damaged valve connection.

The propane cylinder must be constructed and marked in accordance with the specifications for LP gas cylinders of the U.S. Department of Transportation (DOT) or the standard for cylinders, spheres and tubes for transportation of dangerous goods and commission, CAN/CSA-B339.

The cylinder must have a listed overfilling prevention device.

The cylinder must have a connection device compatible with the connection for the appliance.

The cylinder used must include a collar to protect the cylinder valve.

Never connect an unregulated propane cylinder to the heater.

Attach regulator to cylinder. Complete attachment.

Install cylinder.

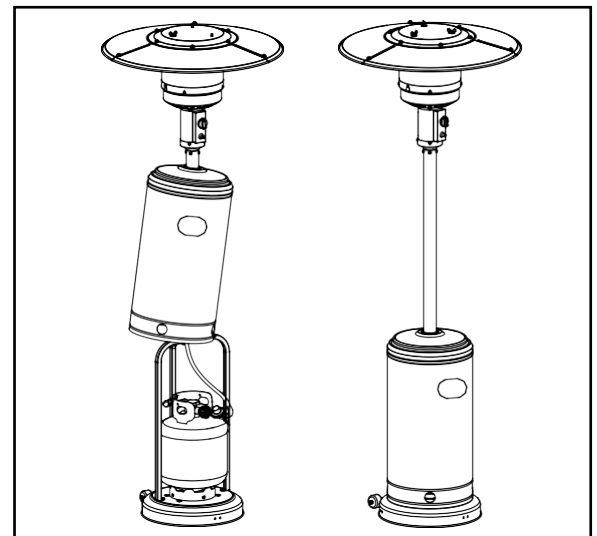
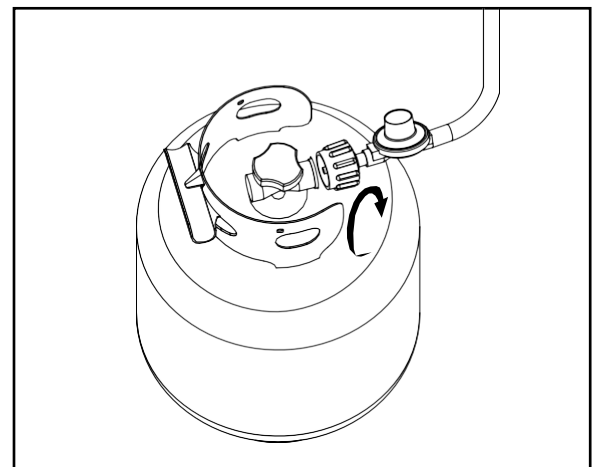

- Do not store a spare LP-gas cylinder under or near this appliance
- Never fill the cylinder beyond 80 percent full
- “Place the dust cap on the cylinder valve outlet whenever the cylinder is not in use. Only install the type of dust cap on the cylinder valve that is provided with the cylinder valve. Other type of caps or plugs may result in leakage of propane.”

## OPERATION INSTRUCTIONS

**Leak Check** (*NOTE: Whenever gas connections are loosened or removed, you must perform a complete leak test.*)

### WARNING

- Perform all leak tests outdoors.
- Extinguish all open flames.
- NEVER leak test when smoking.
- Do not use the heater until all connections have been leak tested and do not leak.

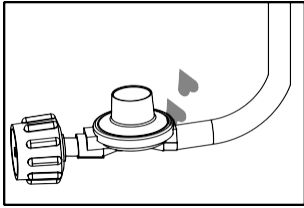

Hose / Regulator  
connection

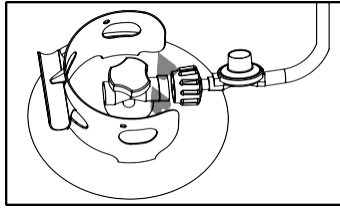

Regulator / Cylinder  
connection

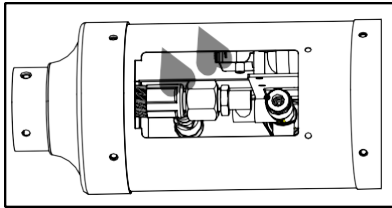

1. Make 2-3 oz. of leak check solution (one part liquid dishwashing detergent and three parts water).
2. Apply several drops of solution where hose attaches to regulator.
3. Apply several drops of solution where regulator connects to cylinder.
4. Make sure all patio heater and light valves are OFF.
5. Turn LP cylinder valve ON.

**If bubbles appear at any connection, there is a leak.**

1. Turn LP cylinder valve OFF.
2. If leak is at hose/regulator connection: tighten connection and perform another leak test. If bubbles continue appearing, the hose should be returned to the place of purchase.
3. If leak is at regulator/cylinder valve connection: disconnect, reconnect, and perform another leak check. If you continue to see bubbles after several attempts, cylinder valve is defective and should be returned to cylinder's place of purchase. If **NO** bubbles appear at any connection, the connections are secure.
4. Complete installation.

## OPERATION INSTRUCTIONS

### DANGER

- CARBON MONOXIDE HAZARD
- For outdoor use only. Never use inside house, or other unventilated or enclosed areas. This heater consumes air (oxygen). Do not use in unventilated or enclosed areas to avoid endangering your life.

**Caution:** Do not attempt to operate until you have read and understand all General Safety Information in this manual and all assembly is complete and leak checks have been performed.

*This appliance shall be used only in a well-ventilated space and shall not be used in a building, garage or any other enclosed area.*

*An appliance may be installed with shelter no more inclusive than:*

- 1) *With walls on all sides, but with no overhead cover.*
- 2) *Within a partial enclosure which includes an overhead cover and no more than two side walls. These side walls may be parallel, as in a breezeway, or at right angles to each other.*
- 3) *Within a partial enclosure which includes an overhead cover and three side walls, as long as 30 percent or more of the horizontal periphery of the enclosure is permanently open.*

Before Turning Gas Supply ON:

1. Your heater was designed and approved for outdoor use only. Do NOT use it inside a building, garage, or any other enclosed area.
2. Make sure surrounding areas are free of combustible materials, gasoline, and other flammable vapors or liquids.
3. Ensure that there is no obstruction to air ventilation. Be sure all gas connections are tight and there are no leaks.
4. Be sure the cylinder cover is clear of debris. Be sure any component removed during assembly or servicing is replaced and fastened prior to starting.

Before Lighting:

1. Heater should be thoroughly inspected before each use, and by a qualified service person at least annually. If relighting a hot heater, always wait at least 5 minutes.
2. Inspect the visible portion of the hose before each use of the appliance. If the hose leaks, it must be replaced prior to operation. Only use the replacement hose assembly specified by manufacturer.
3. The pressure regulator and hose assembly supplied with the appliance must be used. Replacement pressure regulators and hose assemblies must be those specified by the appliance manufacturer.

Lighting:

**Note:** This heater is equipped with a pilot light that allows for safer startups and shutdowns. Pilot must be lit before main burner can be started.

1. Turn the control knob to the "OFF" position.
2. Fully open LP cylinder valve.
3. Open viewing hole by sliding cover to either side (Figure 1).
4. Push control knob in and rotate to pilot position (Figure 2).

**Note:** For initial start or after any cylinder change, hold control knob in for 2 minutes to purge air from gas lines before proceeding.

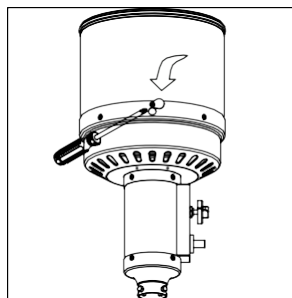

Figure 1

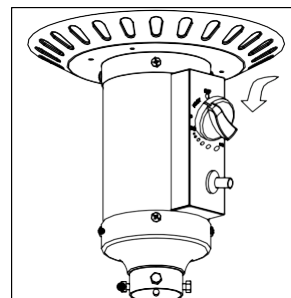

Figure 2

## OPERATION INSTRUCTIONS

5. Push and release the igniter button until pilot flame is visible through viewing hole.
6. Once the pilot is lit, continue to depress the control knob for 30 seconds.
7. If the pilot does not stay lit, repeat steps 4 to 6.
8. If after repeating steps 4 to 6 unit does not light, then
  - Push in control knob and turn counterclockwise to "PILOT" (Figure 3).
  - As you are depressing the control knob, place a long stemmed lighter into the ignition hole on the emitter screen to light the pilot (Figure 4).
  - Repeat step 6.

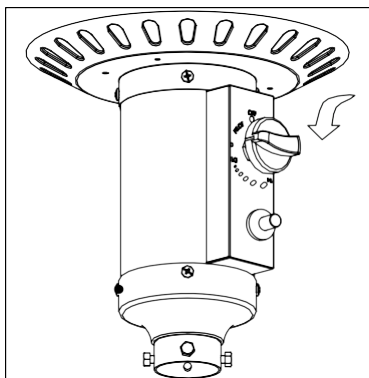

Figure 3

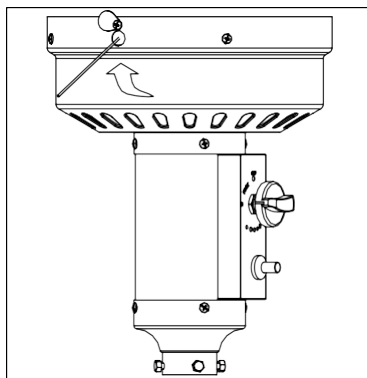

Figure 4

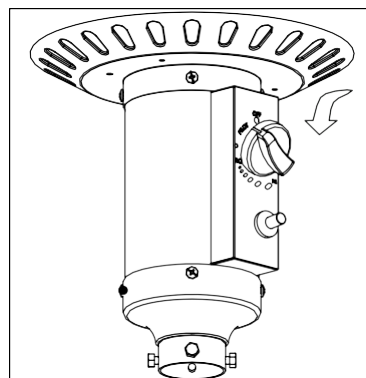
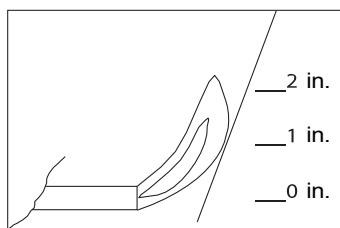

Figure 5

9. Push in and turn the control knob to the "LOW", then release control knob. If you want a higher temperature, push in the control knob and turn counterclockwise to the "HIGH" (Figure 5).

**Note:** Improper operation, can cause injury or property damage. If pilot fails to remain lit, all valves should be closed and a waiting period of at least 5 minutes should pass before attempting to light.



Normal

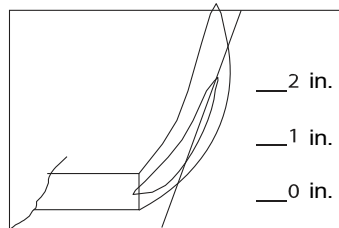

Abnormal

If you experience any ignition problems, please consult "Troubleshooting" on page 18.

**Caution:** Avoid inhaling fumes emitted from the heater's first use. Smoke and odor from the burning of oils used in manufacturing will appear. Both smoke and odor will dissipate after approximately 30 minutes. The heater should NOT produce thick black smoke.

**Note:** The burner may be noisy when initially turned on. To eliminate excessive noise from the burner, turn the control knob to the PILOT position. Then, turn the knob to the level of heat desired.

## OPERATION INSTRUCTIONS

---

### WARNING

#### FOR YOUR SAFETY

Be careful when attempting to manually ignite this heater. Holding in the control knob for more than 10 seconds before igniting the gas will cause a ball of flame upon ignition.

#### When heater is ON:

Emitter screen will become bright red due to intense heat. The color is more visible at night. Burner will display tongues of blue and yellow flame. These flames should not be yellow or produce thick black smoke, indicating an obstruction of airflow through the burners. The flame should be blue with straight yellow tops. If excessive yellow flame is detected, turn off heater and consult “Troubleshooting” on page 18.

#### Re-lighting:

**Note:** For your safety, control knob cannot be turned OFF without first depressing control knob in PILOT position and then rotating it to OFF.

1. Turn control knob to OFF.
2. Wait at least 5 minutes, to let gas dissipate, before attempting to relight Pilot.
3. Repeat the “Lighting” steps on prior page.

### WARNING

#### FOR YOUR SAFETY

Heater will be hot after use. Handle with extreme care.

#### Shut Down:

1. Turn control knob clockwise to PILOT. (Normally, burner will make a slight popping sound when extinguished.) Burner will extinguish but PILOT will remain ON.
2. To extinguish PILOT depress control knob and continue to turn it clockwise to OFF.
3. Turn LP cylinder valve clockwise to OFF and disconnect regulator when heater is not in use.

**Note:** After use, some discoloration of the emitter screen is normal.

### Operation Checklist

For a safe and pleasurable heating experience, perform this check before each use.

#### **Before Operating:**

1. I am familiar with entire owner’s manual and understand all precautions noted.
2. All components are properly assembled, intact and operable.
3. No alterations have been made.
4. All gas connections are secure and do not leak.
5. Wind velocity is below 10 mph.
6. Unit will operate at reduced efficiency below 40°F.
7. Heater is outdoors (outside any enclosure).
8. There is adequate fresh air ventilation.

## Before Operating (continued)

---

9. Heater is away from gasoline or other flammable liquids or vapors.
10. Heater is away from windows, air intake openings, sprinklers and other water sources.
11. Heater is at least 36 in. on top and at least 36 in. on sides from combustible materials.
12. Heater is on a hard and level surface.
13. There are no signs of spider or insect nests.
14. All burner passages are clear.
15. All air circulation passages are clear.
- 16. Children and adults should be alerted to the hazards of high surface temperatures and should stay away to avoid burns or clothing ignition.**
- 17. Young children should be carefully supervised when they are in the area of the heater.**
- 18. Clothing or other protective material should not be hung from the heater, or placed on or near the heater.**
- 19. Any guard or other protective device removed for servicing the heater must be replaced prior to operating the heater.**
- 20. Installation and repair should be done by a qualified service person. The heater should be inspected before use and at least annually by a qualified service person.**
- 21. More frequent cleaning may be required as necessary. It is imperative that control compartment, burner and circulating air passageways of the heater be kept clean.**

### After Operation:

1. Ensure Gas control is in OFF position.
2. LP Gas Tank valve is OFF.
3. Disconnect Gas line.

## CARE AND MAINTENANCE

---

### WARNING

#### FOR YOUR SAFETY:

- Do NOT touch or move heater for at least 45 minutes after use.
- Reflector is hot to the touch.
- Allow reflector to cool before touching.

To enjoy years of outstanding performance from your heater, make sure you perform the following maintenance activities on a regular basis:

Keep exterior surfaces clean.

1. Use warm soapy water for cleaning. Never use flammable or corrosive cleaning agents.
2. While cleaning your unit, be sure to keep the area around the burner and pilot assembly dry at all times. Do not submerge the control valve assembly. If the gas control is submerged in water, DO NOT use it. It must be replaced.
  - a. Keep the appliance area clear and free from combustible materials, gasoline and other flammable vapors and liquids.
  - b. Do not obstruct the flow of combustion and ventilation air.
  - c. Keep the ventilation opening(s) of the cylinder enclosure free and clear from debris.
3. Air flow must be unobstructed. Keep controls, burner, and circulating air passageways clean. Signs of possible blockage include:

## CARE AND MAINTENANCE

---

Visually check portions of the hose assembly located within the confines of the heater post. Inspect the entire hose assembly at least annually by disassembling the reflector and burner. Inspect the hose assembly for evidence of excessive abrasion, cuts, or wear. Suspected areas should be leak tested. Then assemble the reflector and burner again following with step 6 and 10.



Spiders and insects can nest in burner or orifices. This dangerous condition can damage heater and render it unsafe for use. Clean burner holes by using a heavy-duty pipe cleaner. Compressed air may help clear away smaller particles.

Carbon deposits may create a fire hazard. Clean dome and burner screen with warm soapy water if any carbon deposits develop.

*Note: In a salt-air environment (such as near an ocean), corrosion occurs more quickly than normal. Frequently check for corroded areas and repair them promptly.*

### TIP:

Use high-quality automobile wax to help maintain the appearance of your heater. Apply to exterior surfaces from the pole down. Do not apply to emitter screen or domes.

### Stop Operation Immediately If Any Of The Following Occur:

- Gas odor with extreme yellow tipping of flame.
- Heater does NOT reach the desired temperature.
- Heater glow is excessively uneven.
- Heater makes popping noises.

### Storage

Between uses:

- Turn Control Knob OFF.
- Disconnect LP source.
- Store heater upright in an area sheltered from direct contact with inclement weather (such as rain, sleet, hail, snow, dust and debris).
- If desired, cover heater to protect exterior surfaces and to help prevent build-up in air passages.

*Note: Wait until heater is cool before covering.*

### ***During periods of extended inactivity or when transporting:***

- Turn Control Knob OFF.
- Disconnect LP source and move to a secure, well-ventilated location outdoors.
- Store heater upright in an area sheltered from direct contact with inclement weather (such as rain, sleet, hail, snow, dust and debris).
- If desired, cover heater to protect exterior surfaces and to help prevent build-up in air passages. Never leave LP cylinder exposed to direct sunlight or excessive heat.

***Note: Wait until heater is cool before covering.***

### Service

Only a qualified service person should repair gas passages and associated components.

***Caution: Always allow heater to cool before attempting service.***

## TROUBLESHOOTING

PROBLEM	POSSIBLE CAUSE	CORRECTIVE ACTION
Pilot won't light  Note: Heater operates at reduced efficiency below 40°F (5°C)	Cylinder valve is closed	Open valve
	Blockage in orifice or pilot tube	Clean or replace orifice or pilot tube
	Air in gas line	Open gas line and bleed it (pressing control knob in) for not more than 1 - 2 minutes or until you smell gas
	Low gas pressure with cylinder valve fully open	Turn cylinder valve OFF and replace cylinder
	Igniter fails	Use match to light pilot; obtain new igniter and replace
Pilot won't stay lit	Dirt built up around pilot	Clean dirt from around pilot
	Connection between gas valve and pilot assembly is loose	Tighten connection and perform leak check
	Thermocouple is not operating correctly	Replace thermocouple
Burner won't light	Propane cylinder is frosted over	Wait until the propane cylinder warms up and becomes unfrosted
	Blockage in orifice	Clear blockage
	Control knob is not in ON position	Turn control knob to ON
Burner flame is low	Gas pressure is low	Turn cylinder valve OFF and replace cylinder
	Outdoor temperature is less than 40°F and tank is less than 1/4 full	Use a full cylinder
	Control knob fully ON	Check burner and orifices for blockage
Carbon build-up	Dirt or film on reflector and burner screen	Clean reflector and burner screen
Thick black smoke	Blockage in burner	Remove blockage and clean burner inside and outside