

INSTALLATION

5*40 Chipboard screw

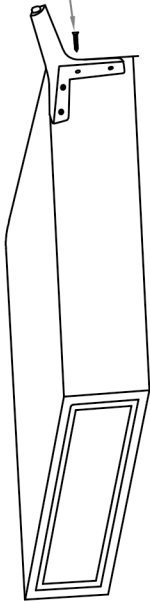

1st process : Each of the legs is mounted with 4 pieces of 5*40 chipboard screws

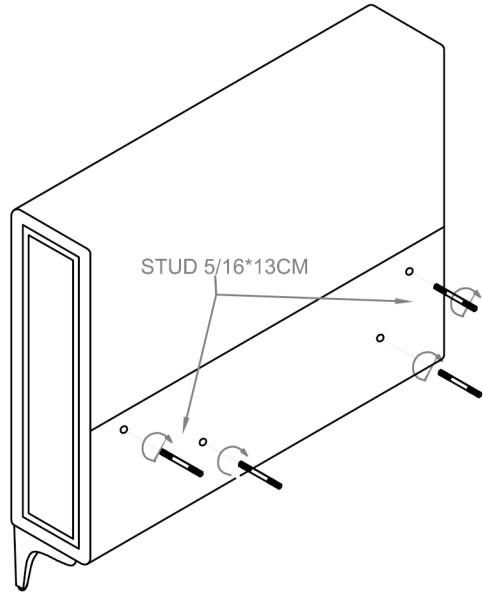

2nd process : 5/16*13 studs are inserted into the holes on the arm taken out of the packaging

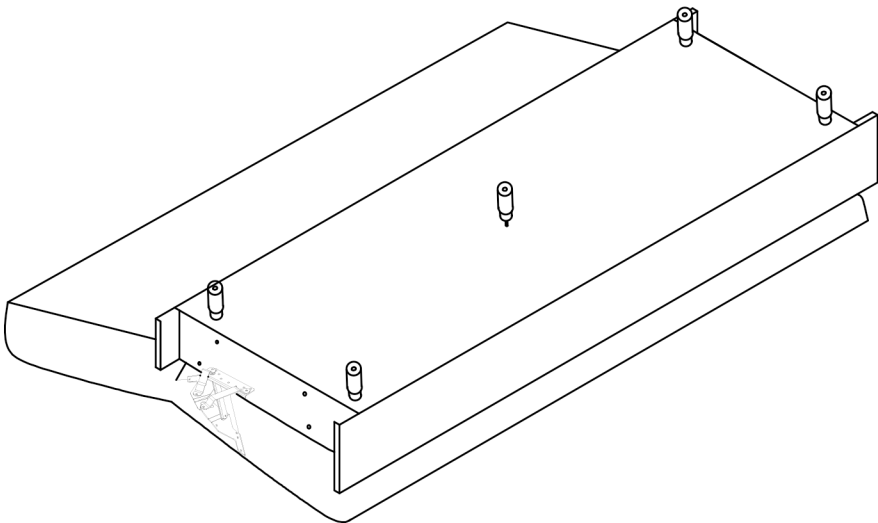

3rd process : 5 middle legs of the sofa taken out of the packaging are screwed to the plastic leg fastening apparatus mounted on the case

INSTRUCTION

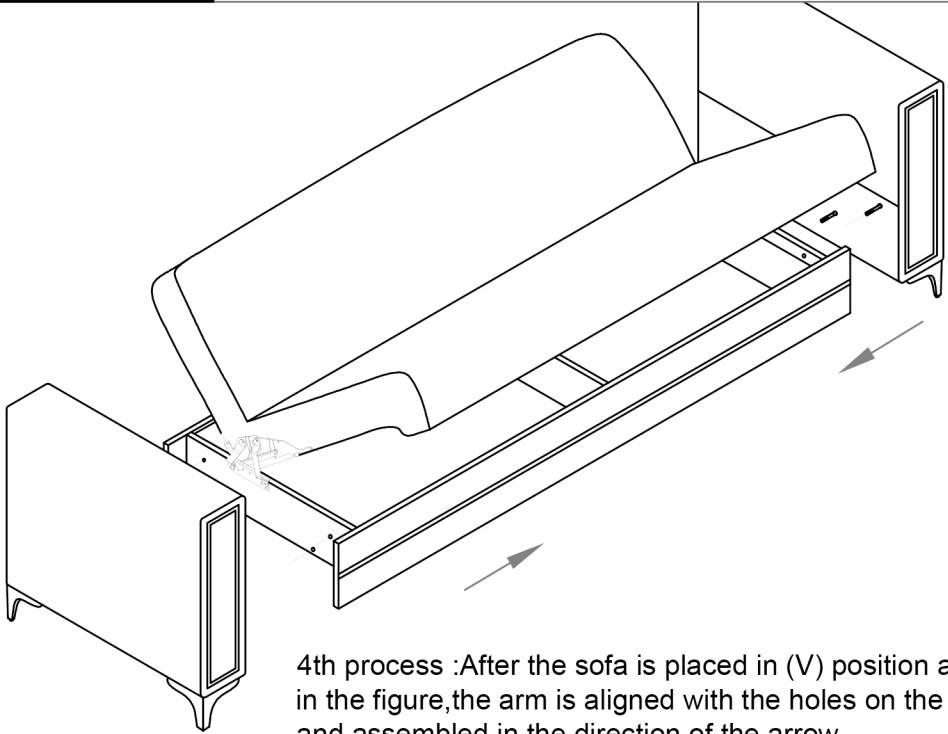

4th process :After the sofa is placed in (V) position as shown in the figure,the arm is aligned with the holes on the frame and assembled in the direction of the arrow

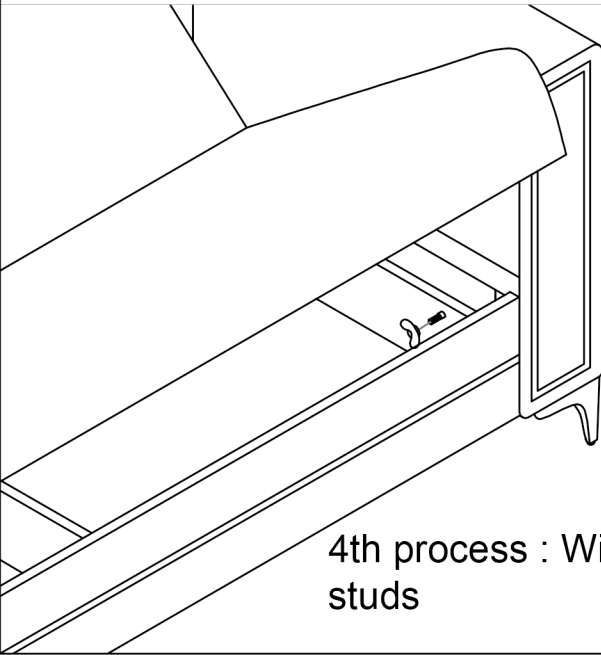

4th process : Wing nuts are mounted on the studs