

Lit Cabinet / Cabinet bed

Instructions d'assemblage
Assembly instructions

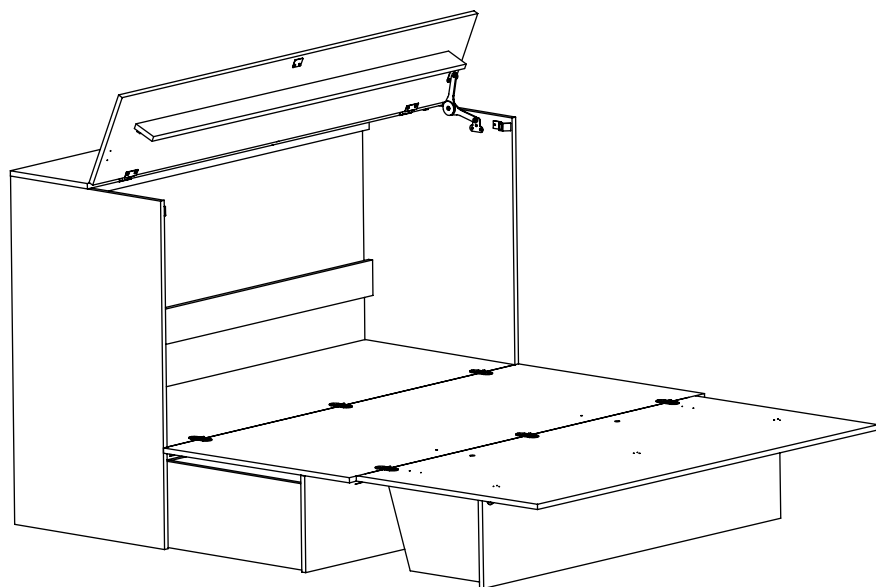
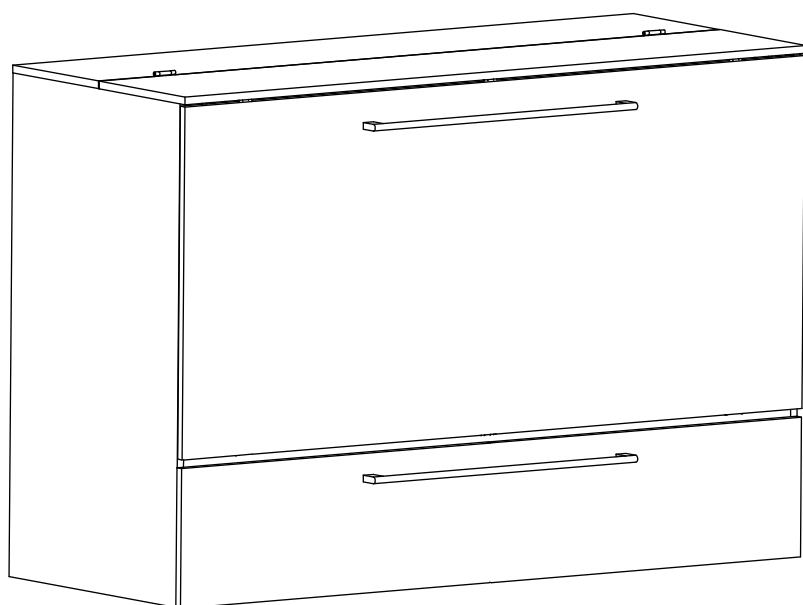

**Si le meuble ne fonctionne pas ou s'il manque une pièce, contactez:
Ne contactez pas le magasin ou le revendeur.**

**If the furniture does not work or if a part is missing, contact:
Do not contact the store or dealer.**

PIÈCES / PARTS

? POUR TOUTE QUESTION /
FOR ANY QUESTION





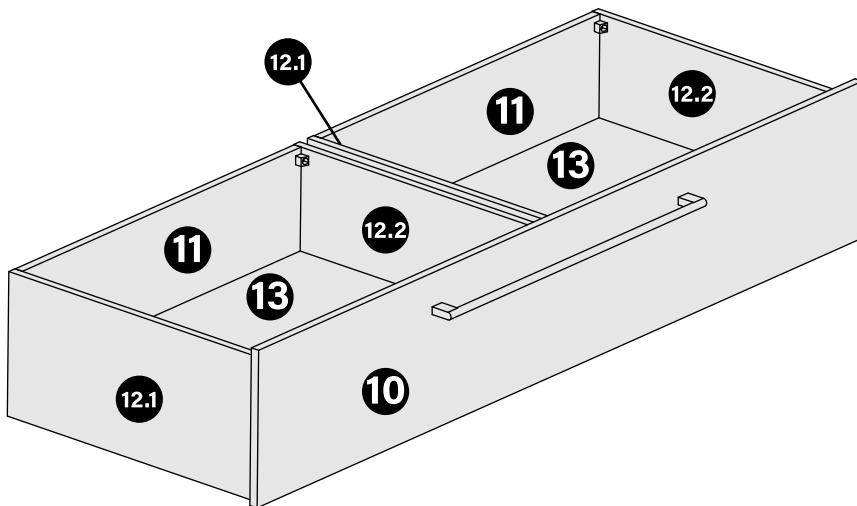
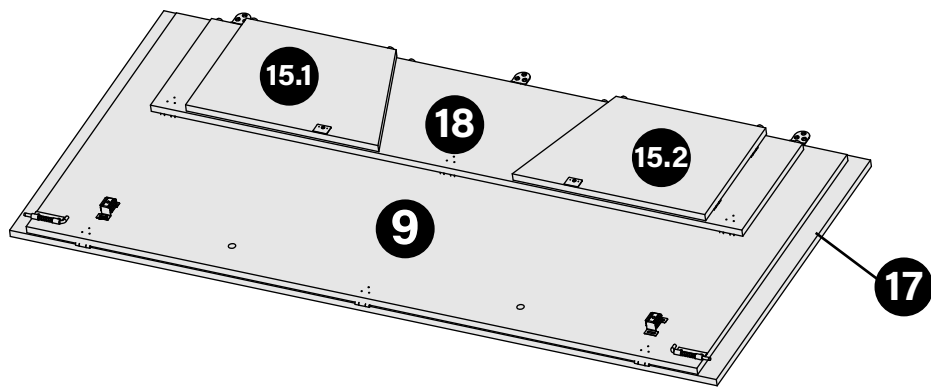
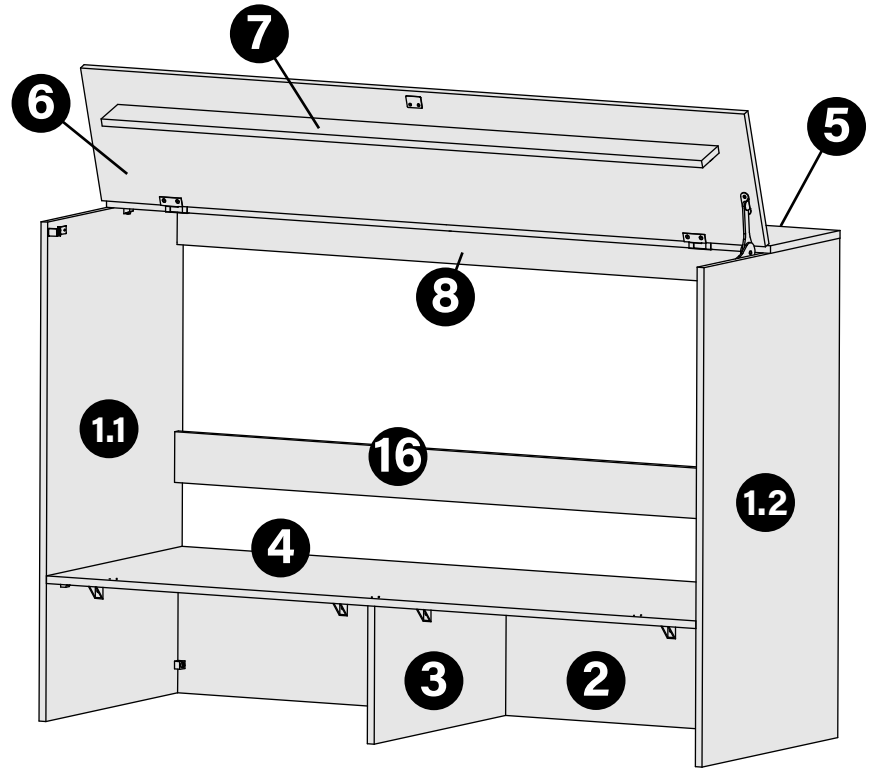



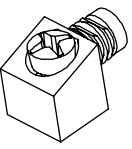
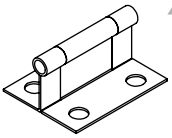
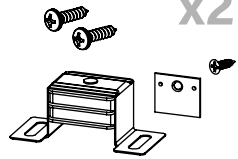
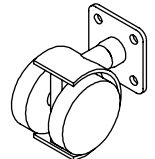
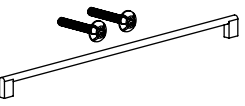
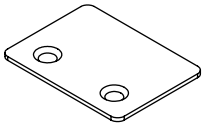
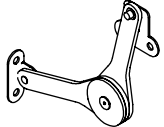
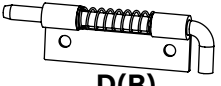
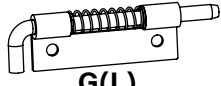
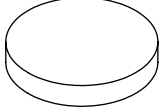



support@evolutek.ca



QUINCAILLERIE / HARDWARE

| | | | | |
|---|--|--|--|---|
|  <p>x63 + 2 extras</p> <p>CAM-MB-B</p> |  <p>x4</p> <p>LOCK-TI-B</p> |  <p>x2</p> <p>PEN-T-N</p> |  <p>x2</p> <p>LOCK-AI-20-A</p> |  <p>x8</p> <p>100335</p> |
|  <p>x2</p> <p>POI-BK-640mm</p> |  <p>x1</p> <p>Protection plate</p> |  <p>x1</p> <p>BRA-RET-HUC</p> |  <p>x2</p> <p>Latch Catch</p> |  <p>x13</p> <p>PEN-M-N</p> |
|  <p>x1</p> <p>D(R)</p> <p>Spring Latch R</p> |  <p>x1</p> <p>G(L)</p> <p>Spring Latch L</p> |  <p>x6</p> <p>Feutre</p> | | |

VIS / SCREWS

| | | | |
|--|---|--|---|
|  <p>x36</p>  <p>VIS-P-6x58</p> |  <p>x9</p>  <p>VIS-P-8x58</p> |  <p>x86</p>  <p>VIS-P-8x58-NOI Tête noire / Black head</p> |  <p>x2</p>  <p>VIS-R-6x12</p> |
|  <p>x8</p>  <p>VIS-R-8x58</p> | <p>Taille réelle Actual size</p> | | |

REMARQUES PARTICULIÈRES / SPECIAL REMARKS

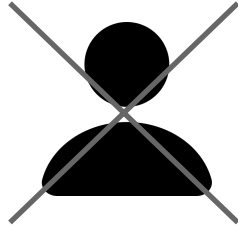
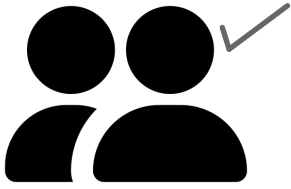

Requiert 2 personnes /
Requires 2 people

OUTILS / TOOLS

+ Tête phillips /
Phillips head

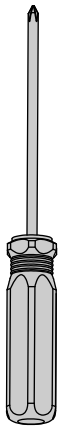

TOURNEVIS / SCREW DRIVER

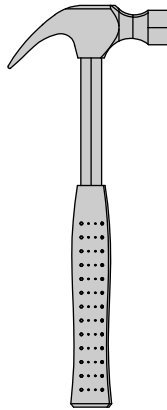

MARTEAU / HAMMER



Veillez monter le meuble sur un tapis afin d'éviter
d'abîmer des pièces ou le plancher.

Please assemble the furniture on a carpet
to avoid damaging parts or the floor.



Petits coups / little taps

ATTENTION:

Faire attention de bien viser le bloc et de ne pas frapper trop fort avec le marteau. Frapper directement sur le panneau avec un marteau pourrait endommager le panneau.

WARNING:

Be careful to aim at the block and not hit it too hard with the hammer. Hit directly on the panel with a hammer could damage the panel.

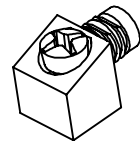

Mini bloc

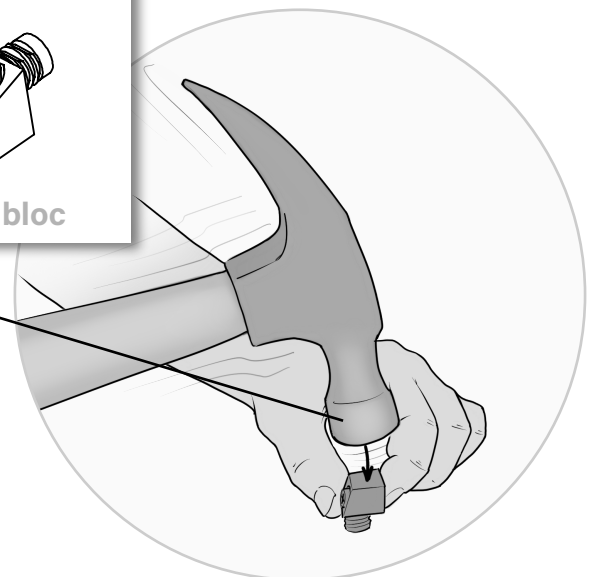

ASSEMBLAGE DU CAISSON / CABINET ASSEMBLY

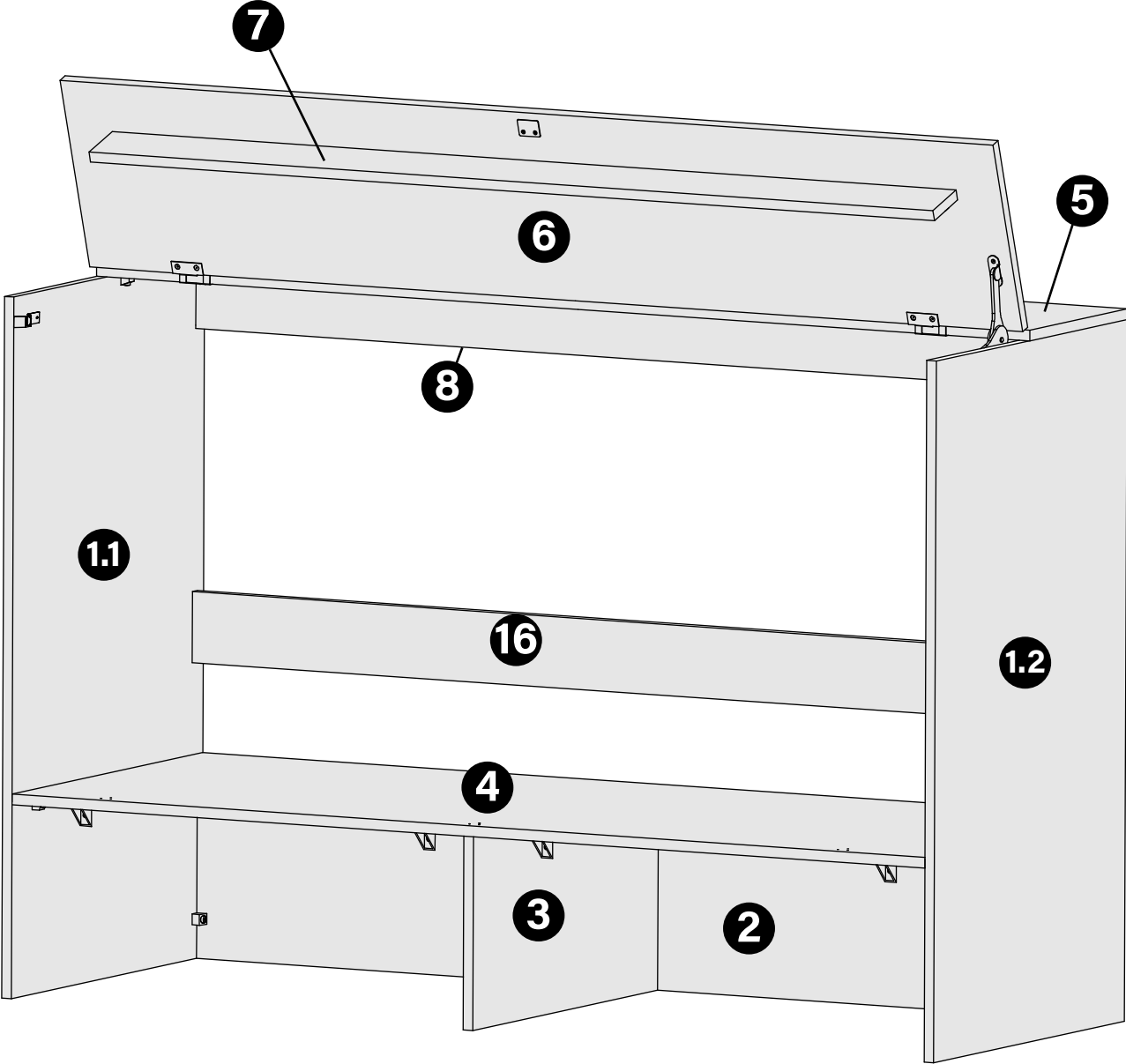

1

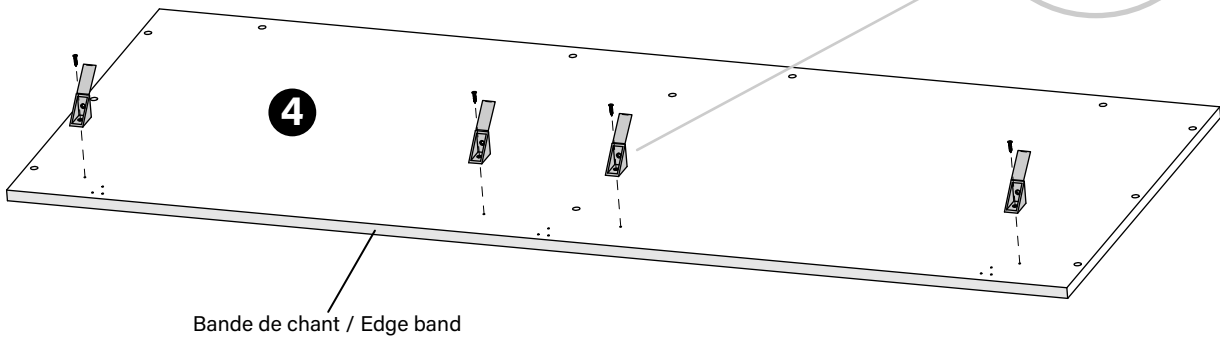
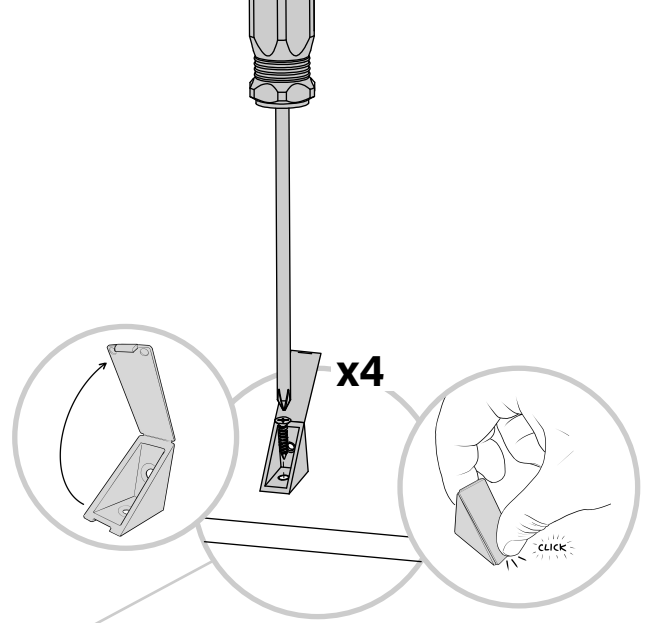

2

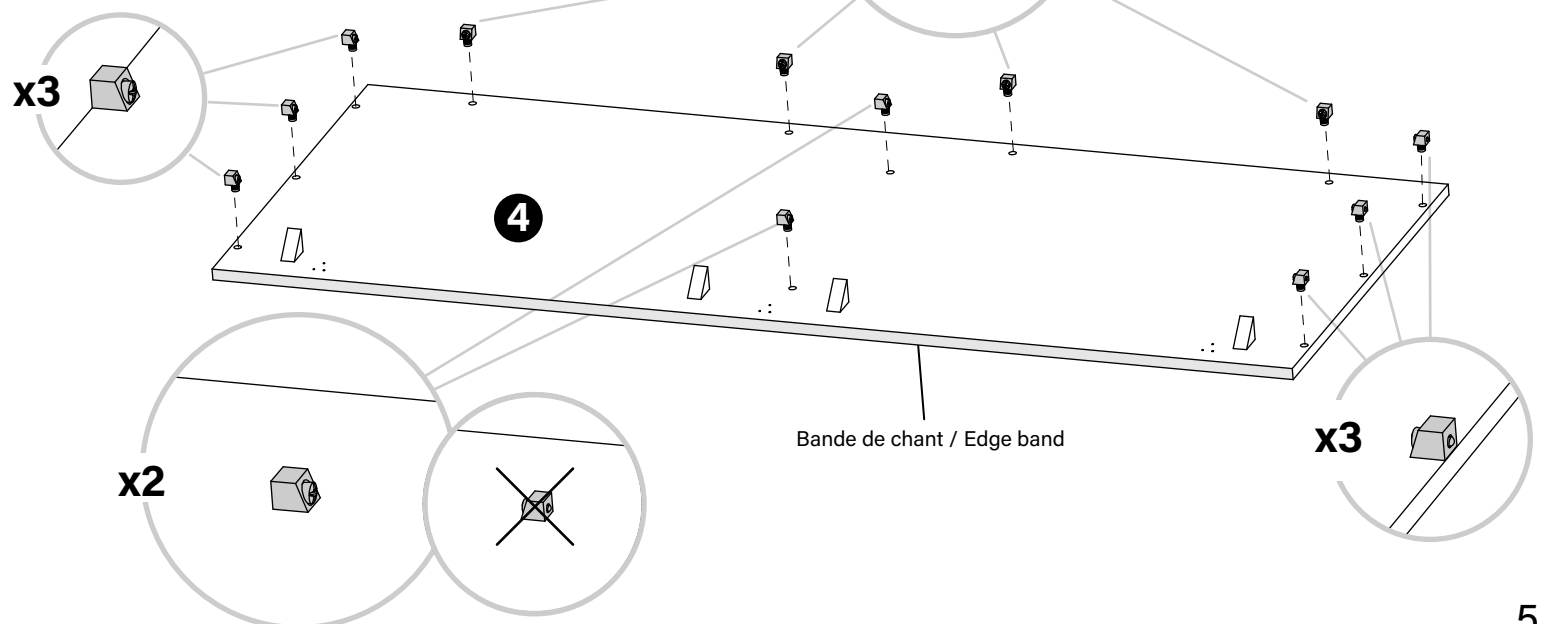
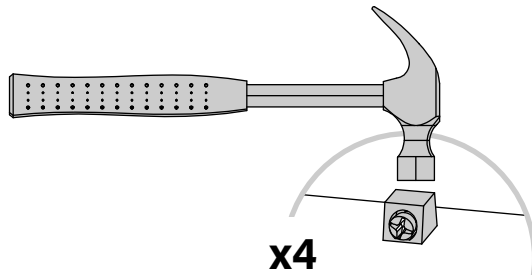

3

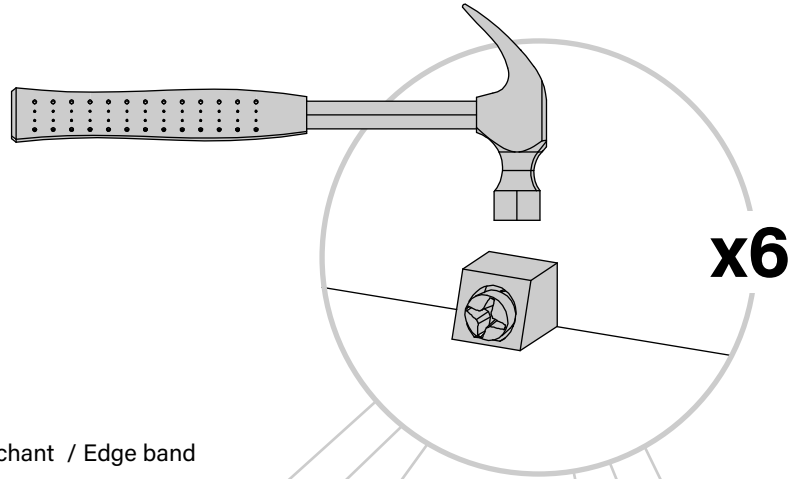

Bande de chant / Edge band

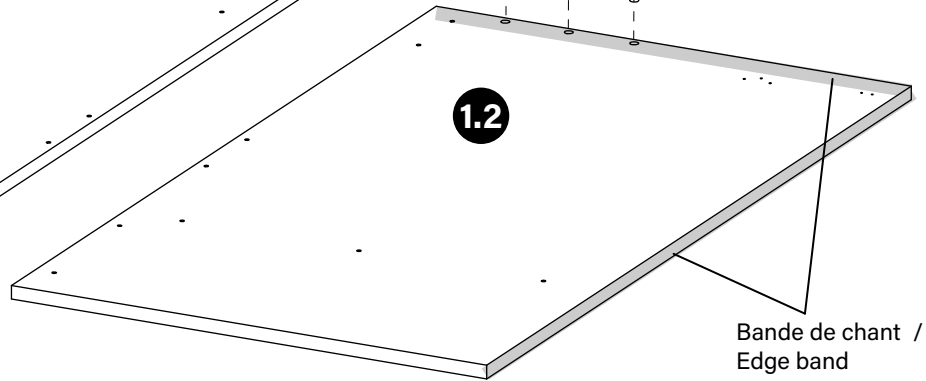
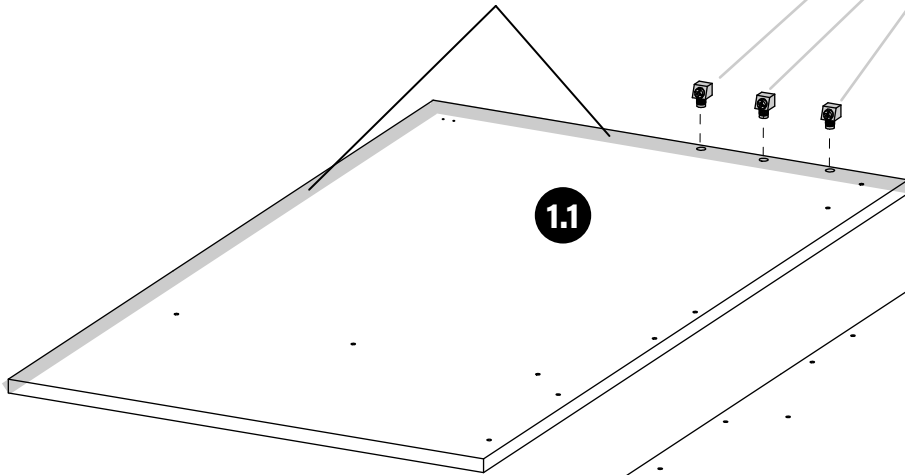

4

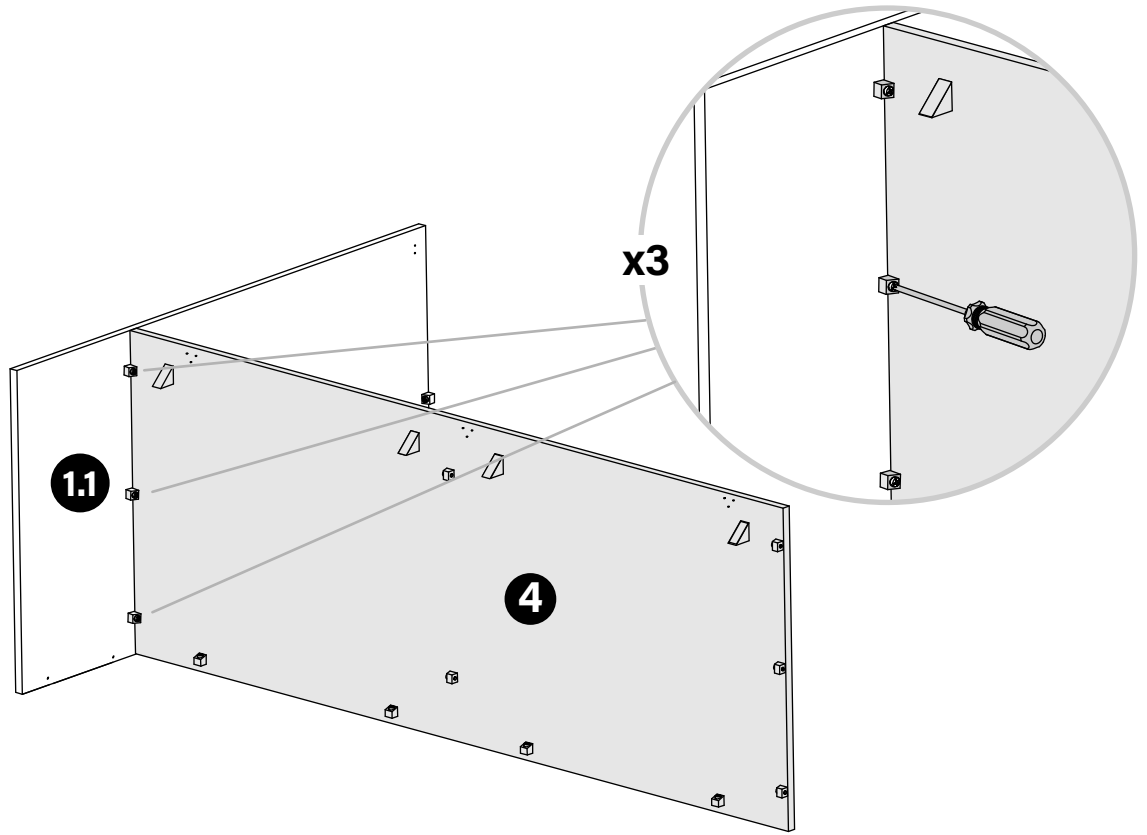

5

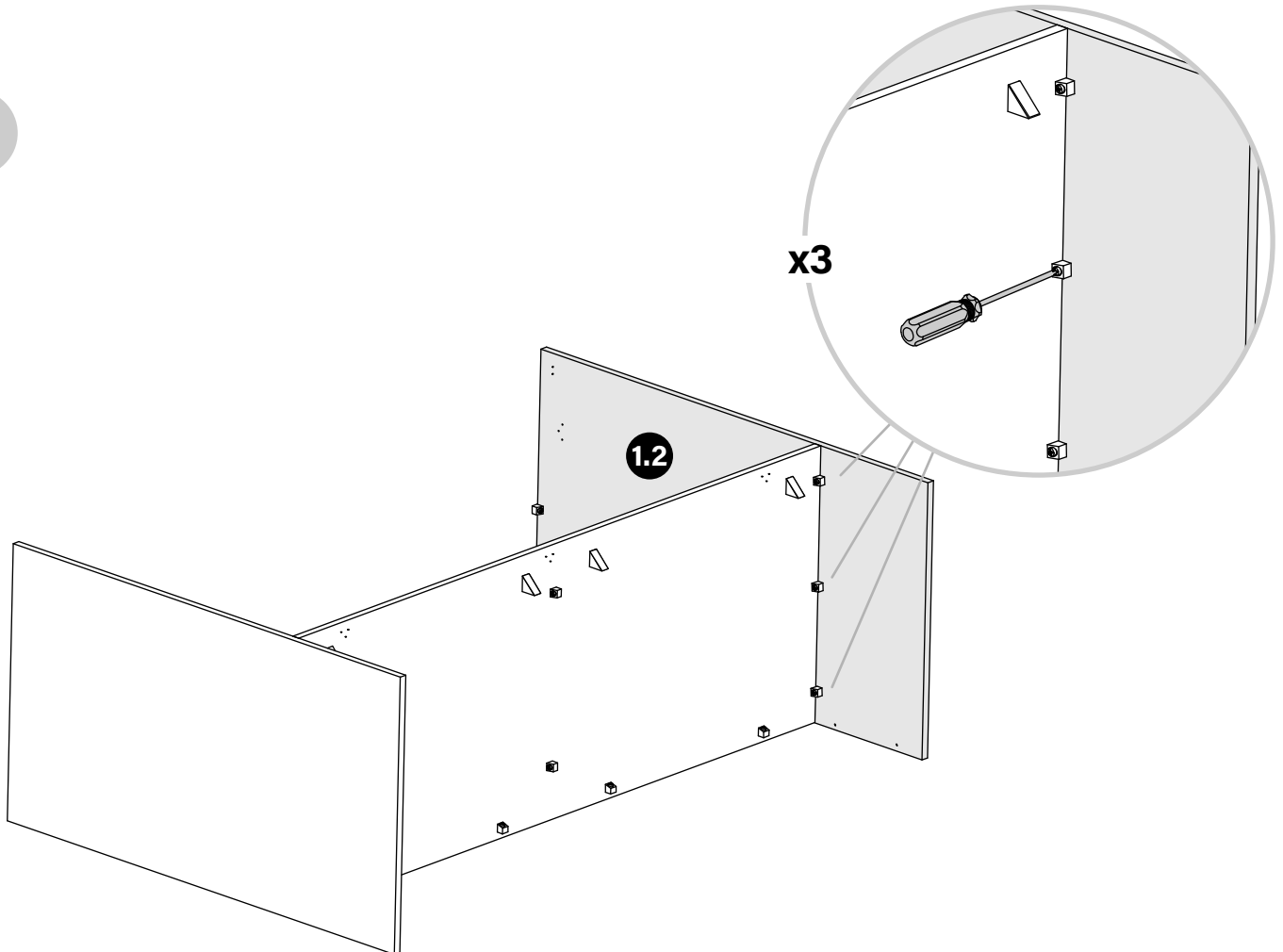

6

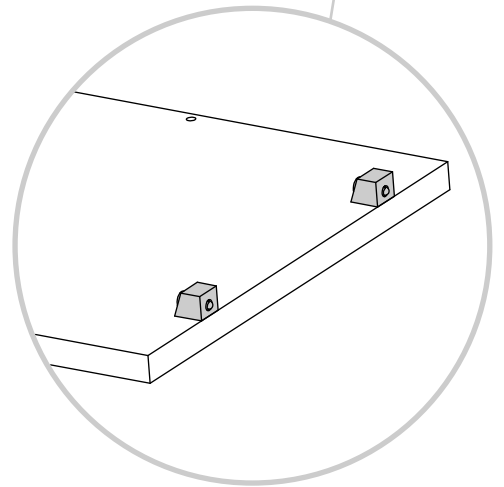
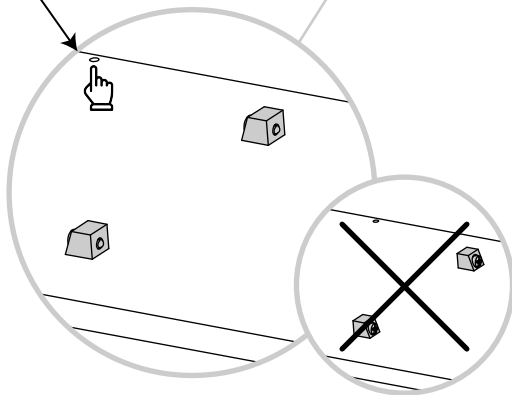
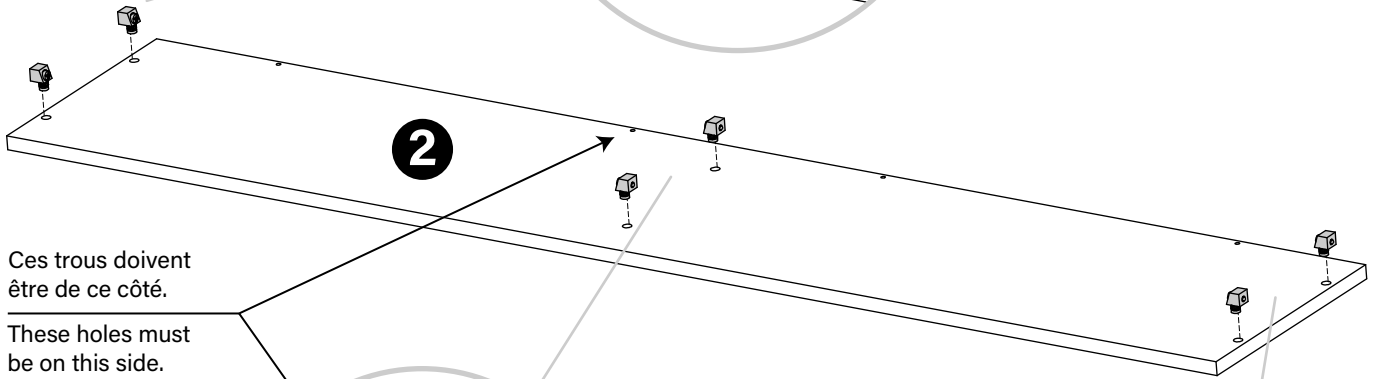
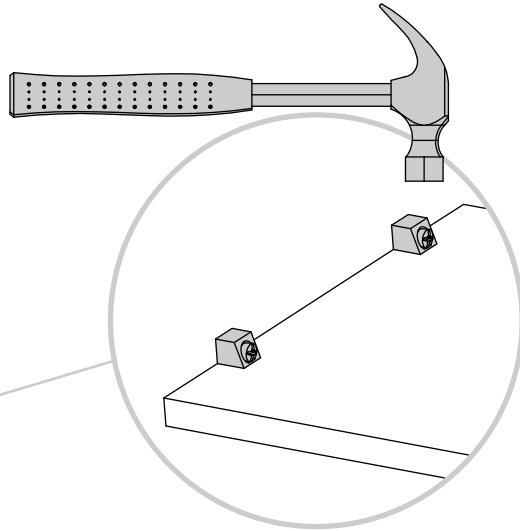

7

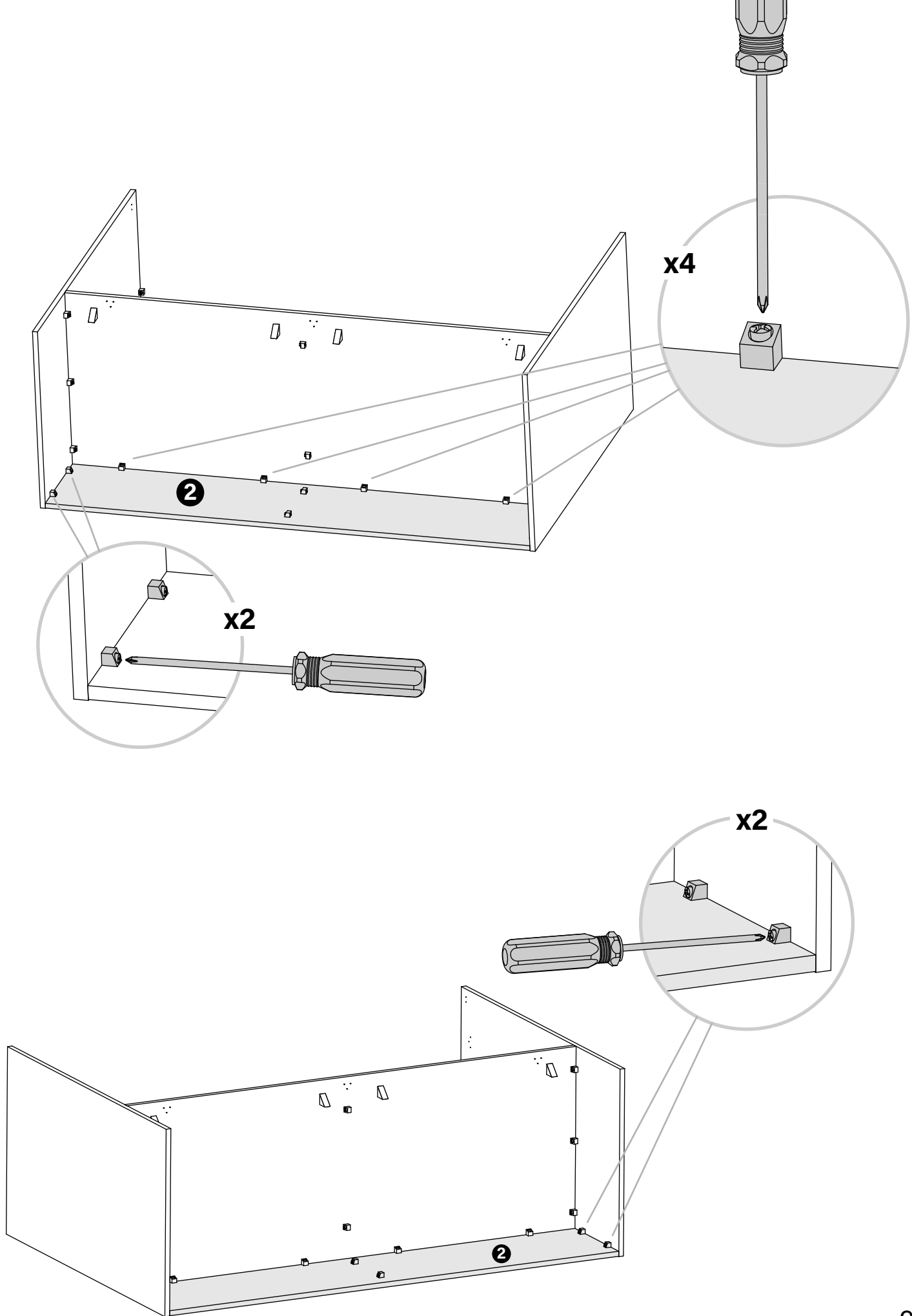

8

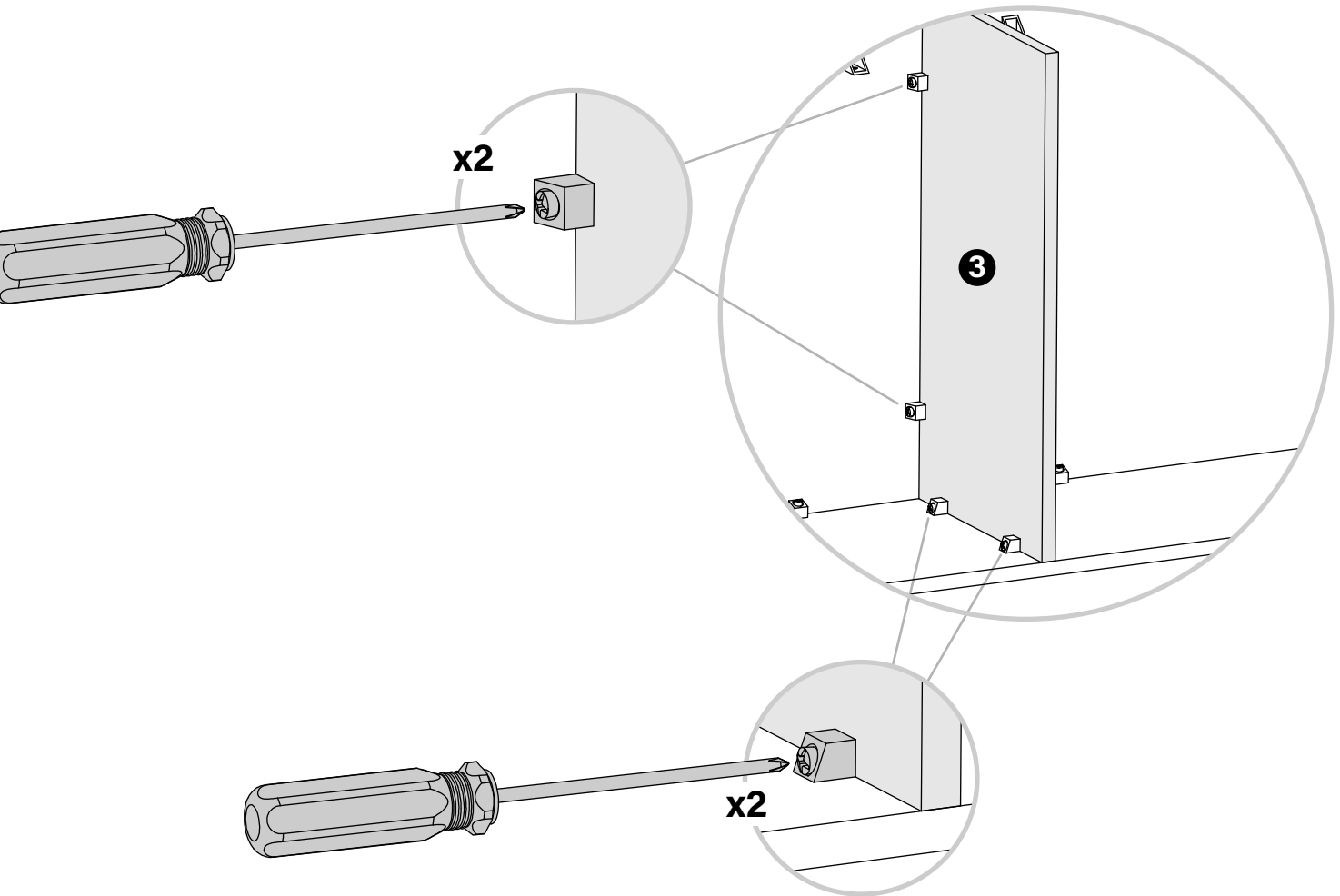
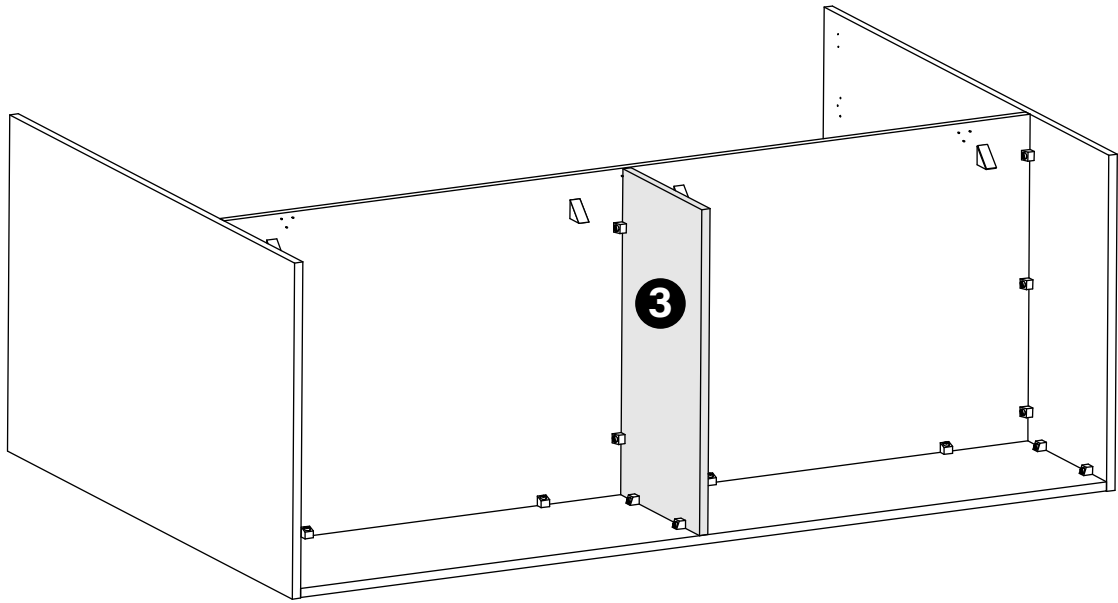

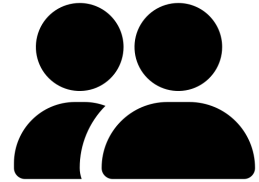
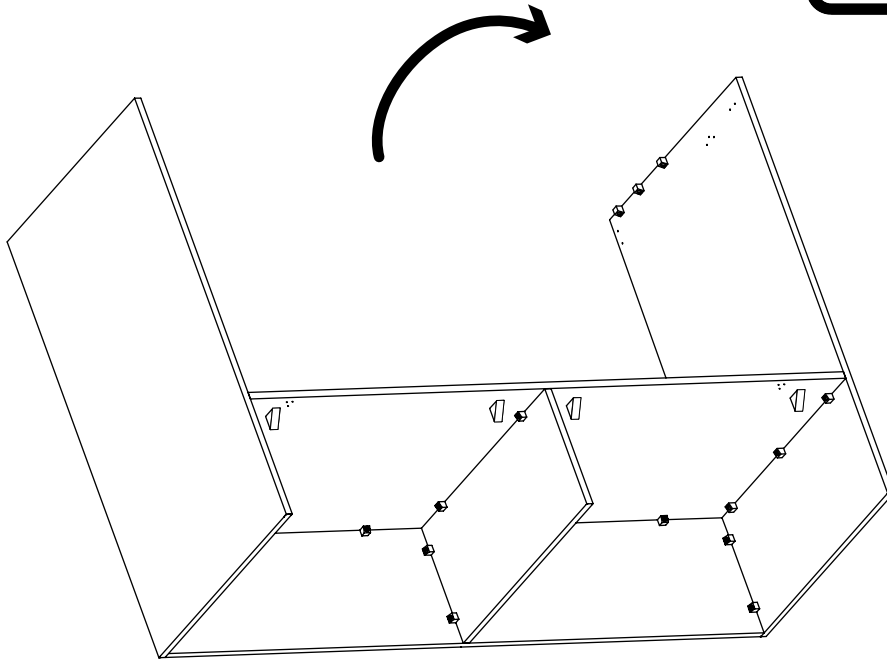

2 personnes requises pour
mettre le meuble debout

2 people required to
stand the furniture

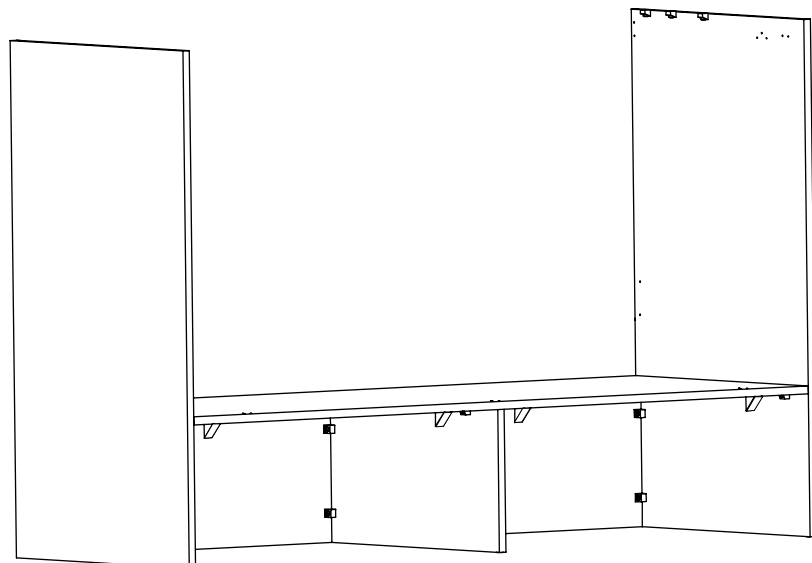

10

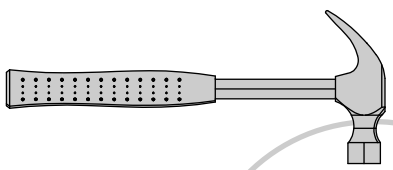

x2

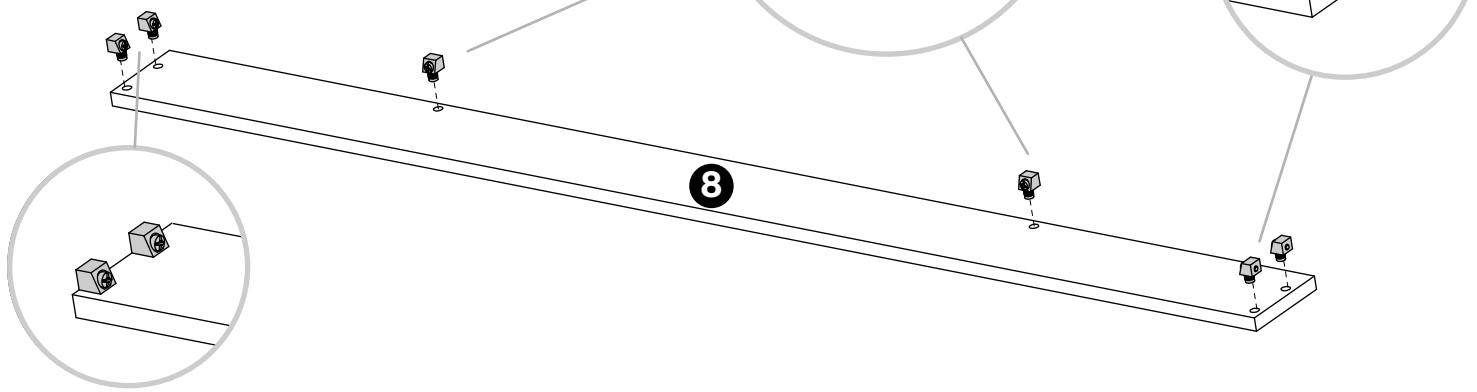

11

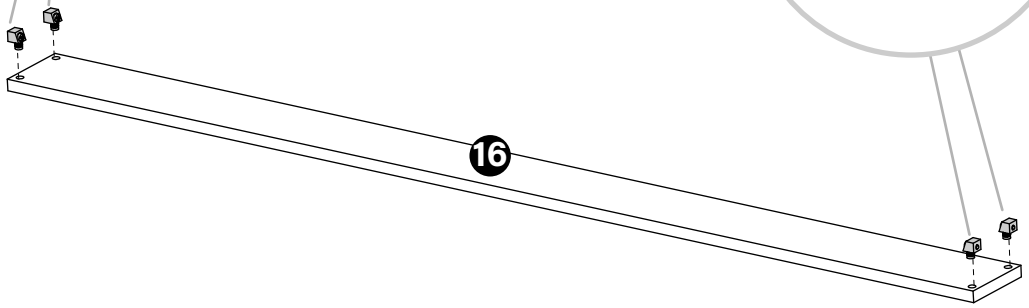
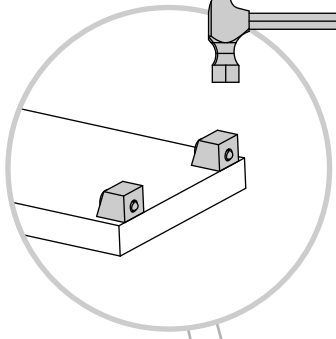
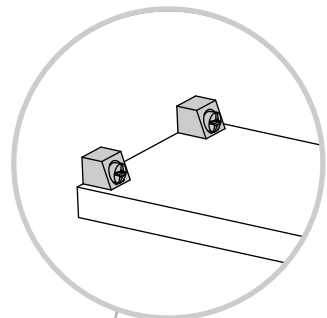
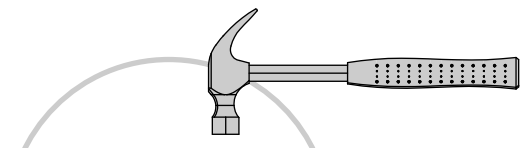
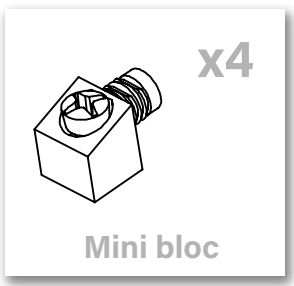

12

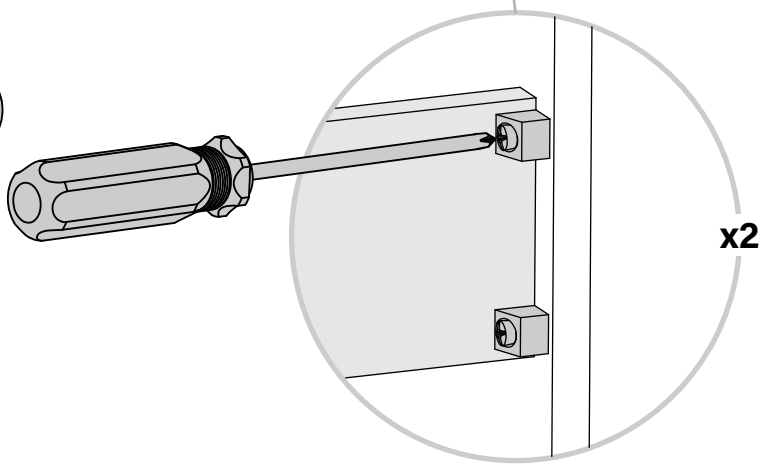
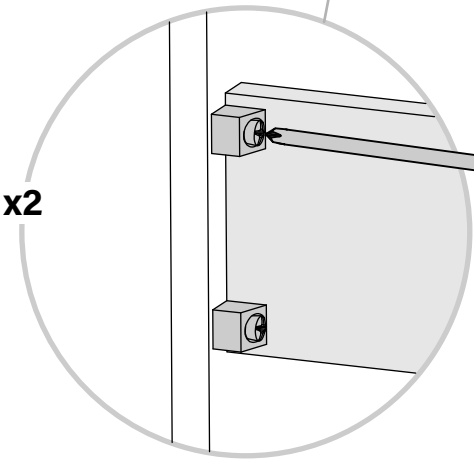
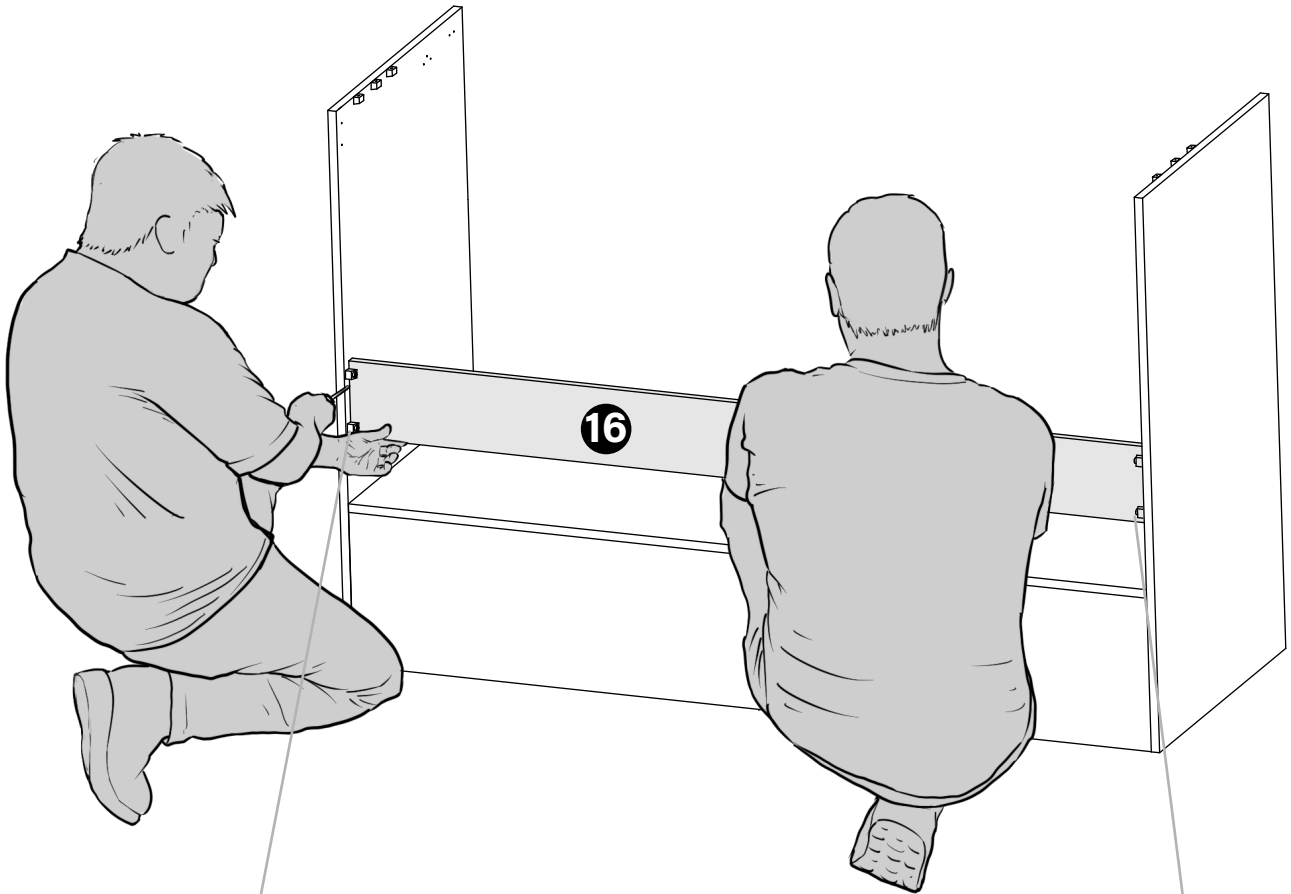

13

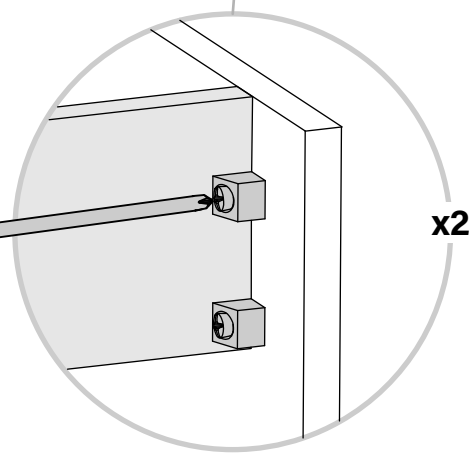
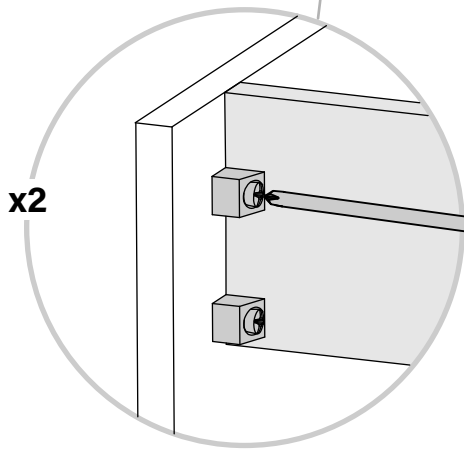
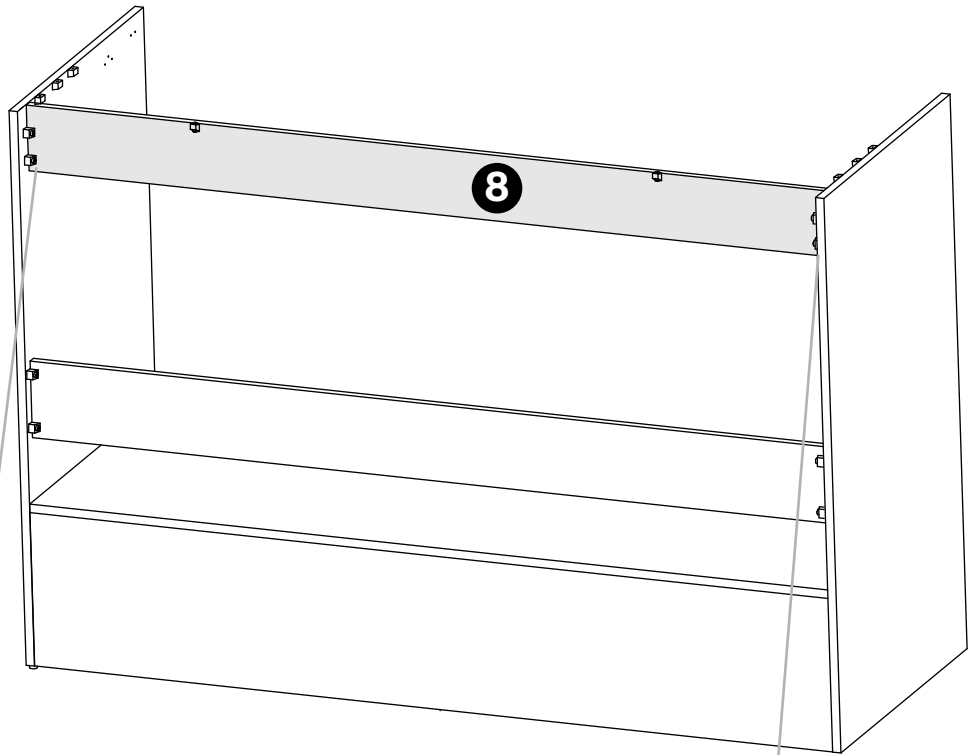

14

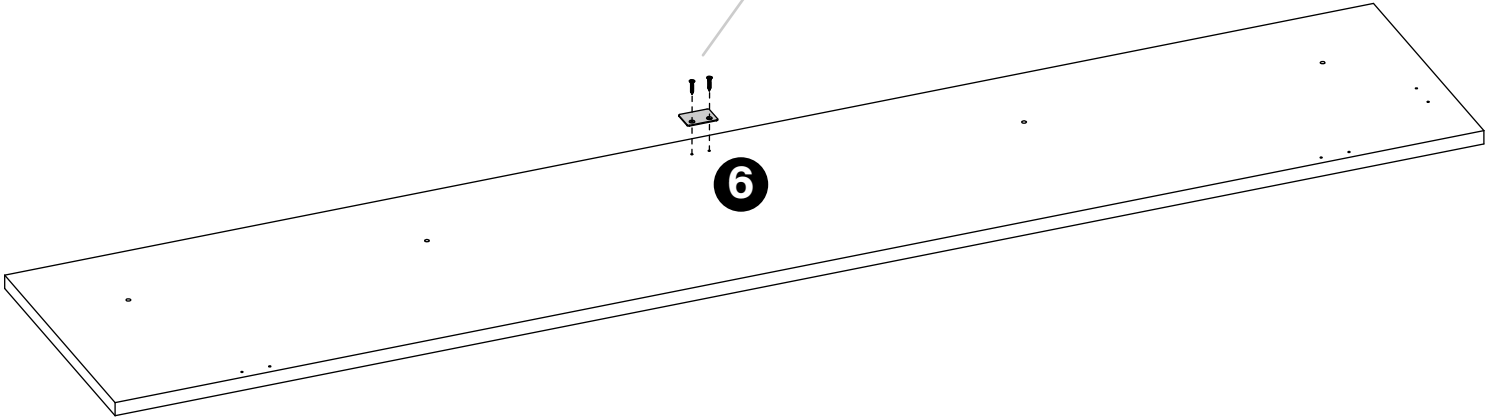
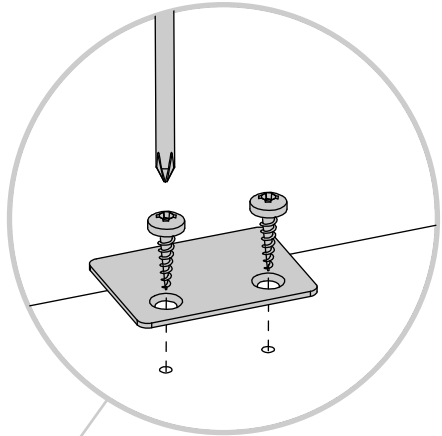
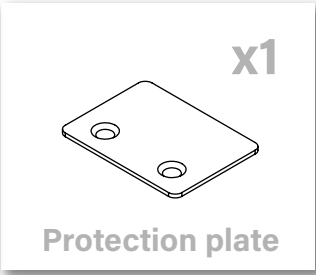
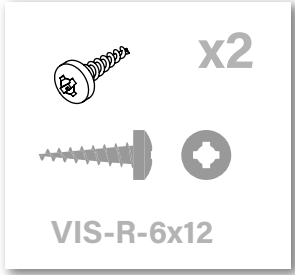

15

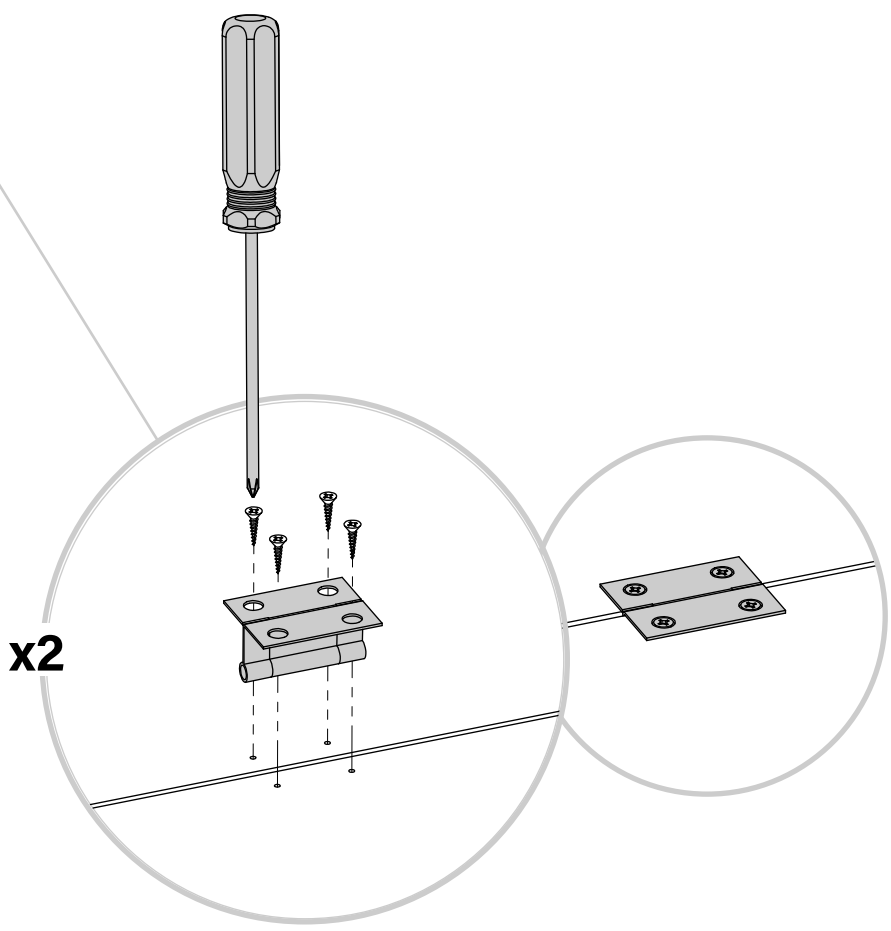
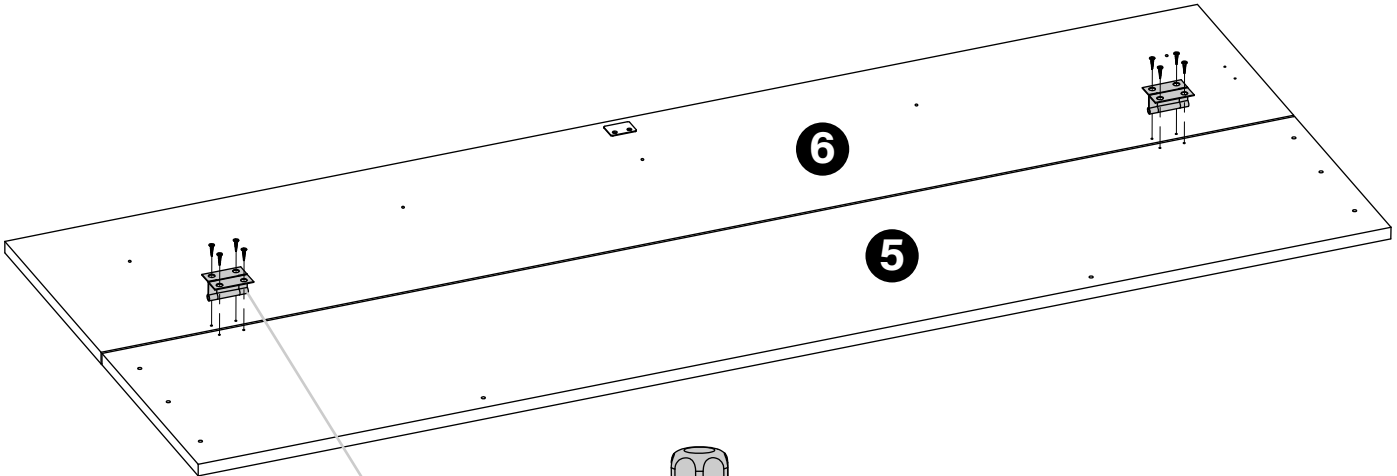
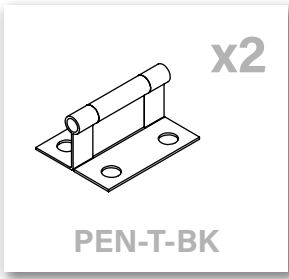
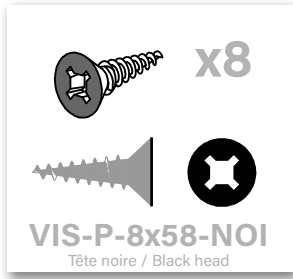

16

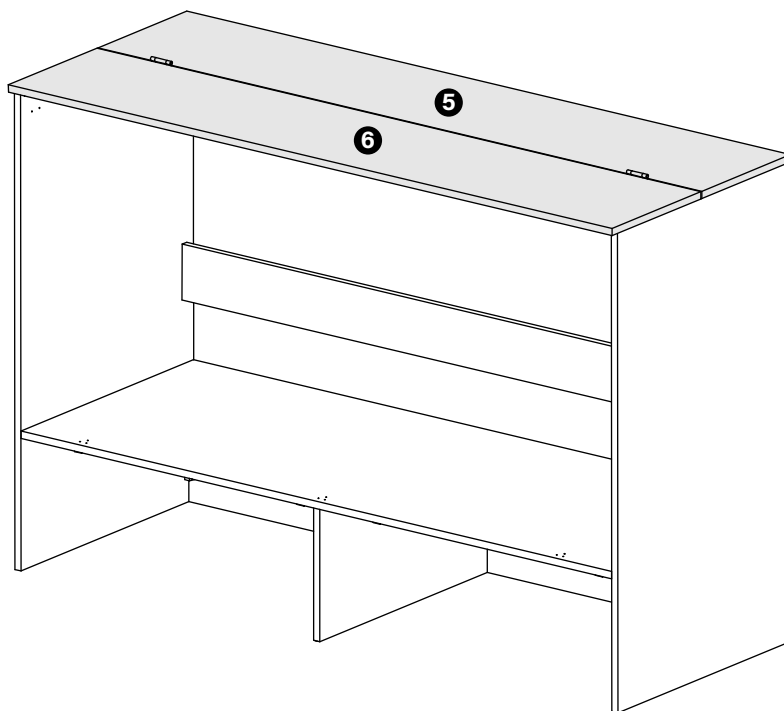
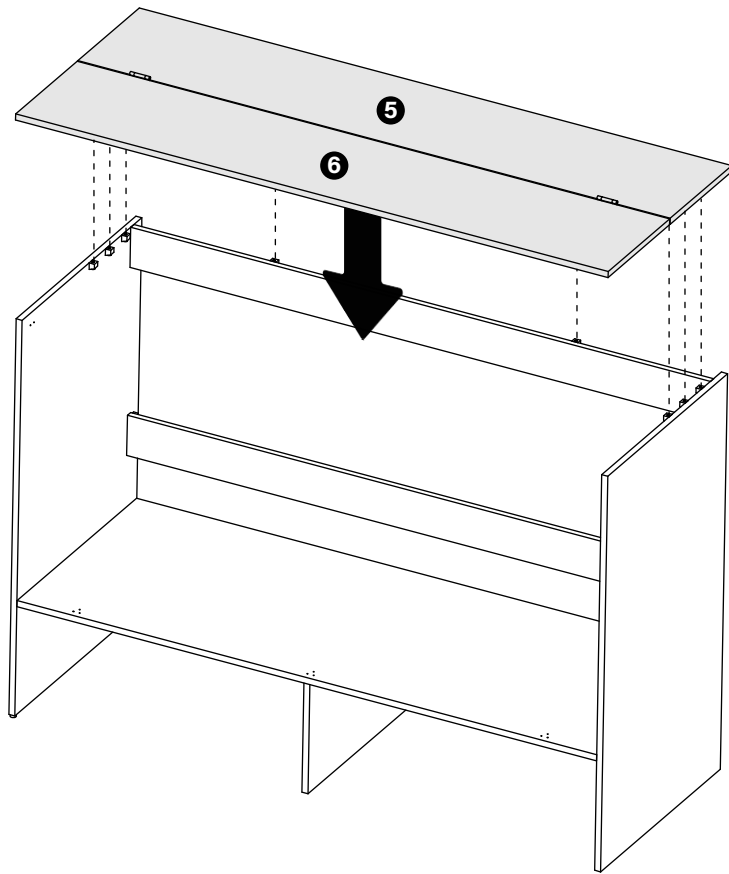

17

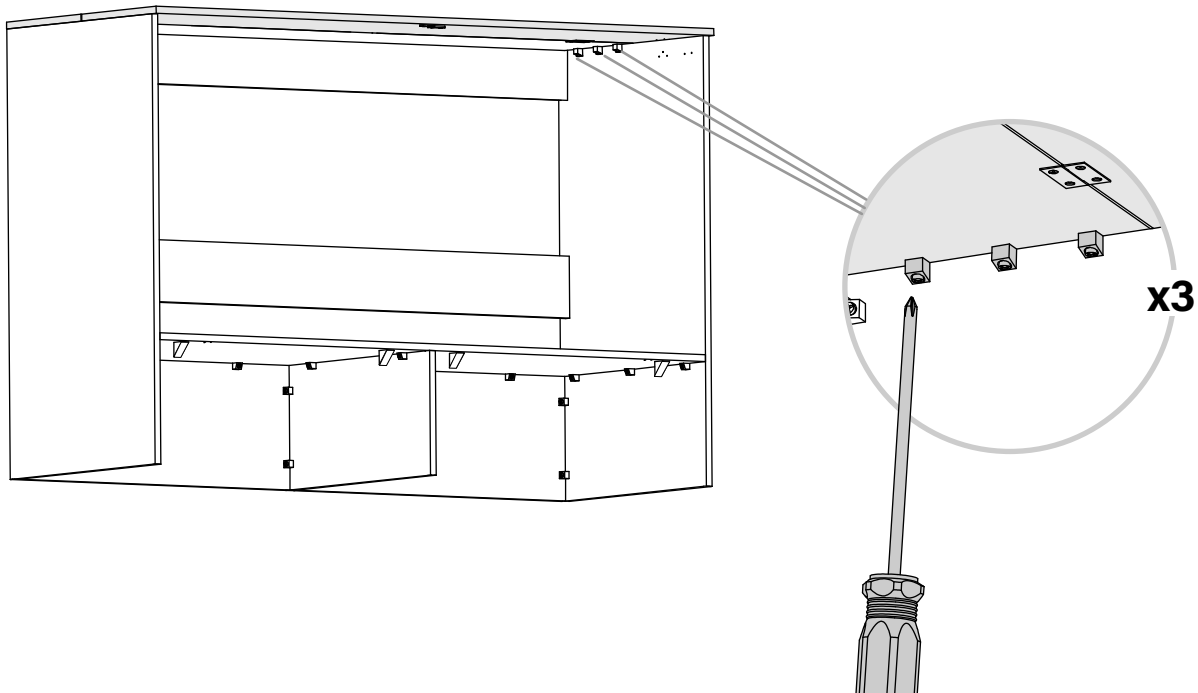
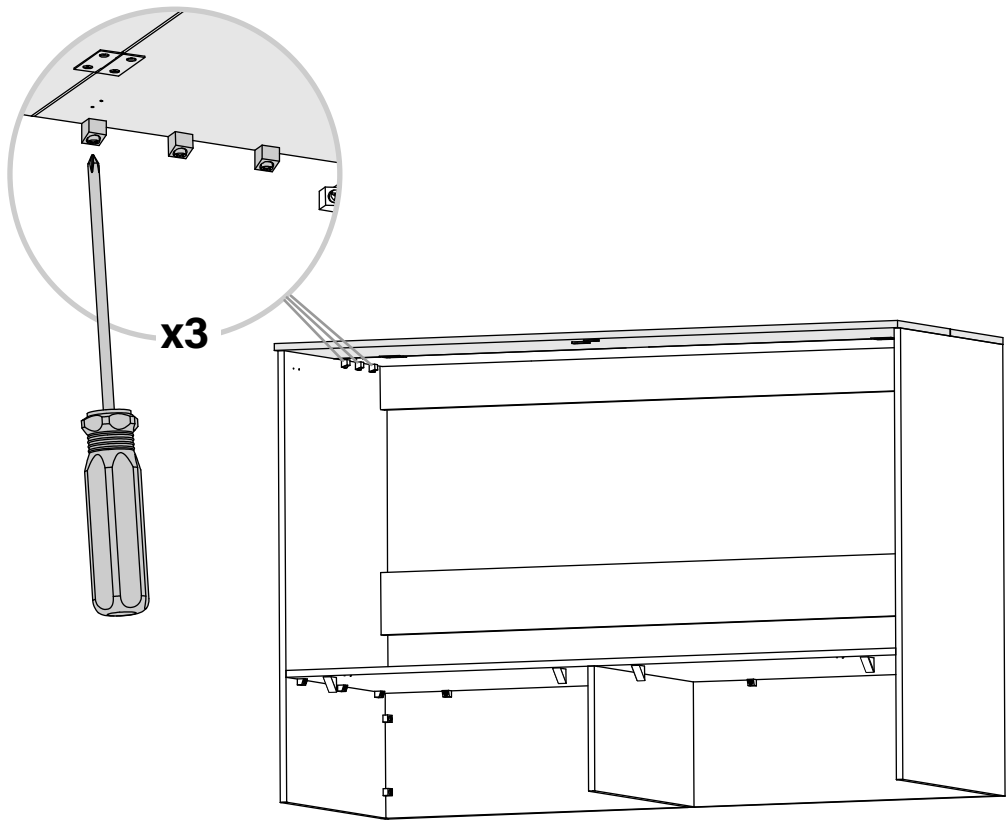

18

DERRIÈRE
BACK

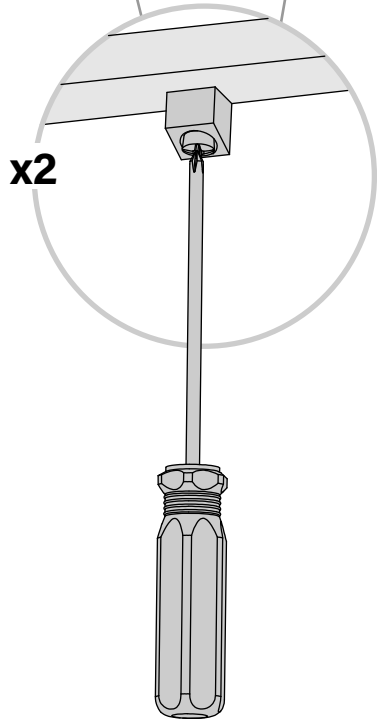
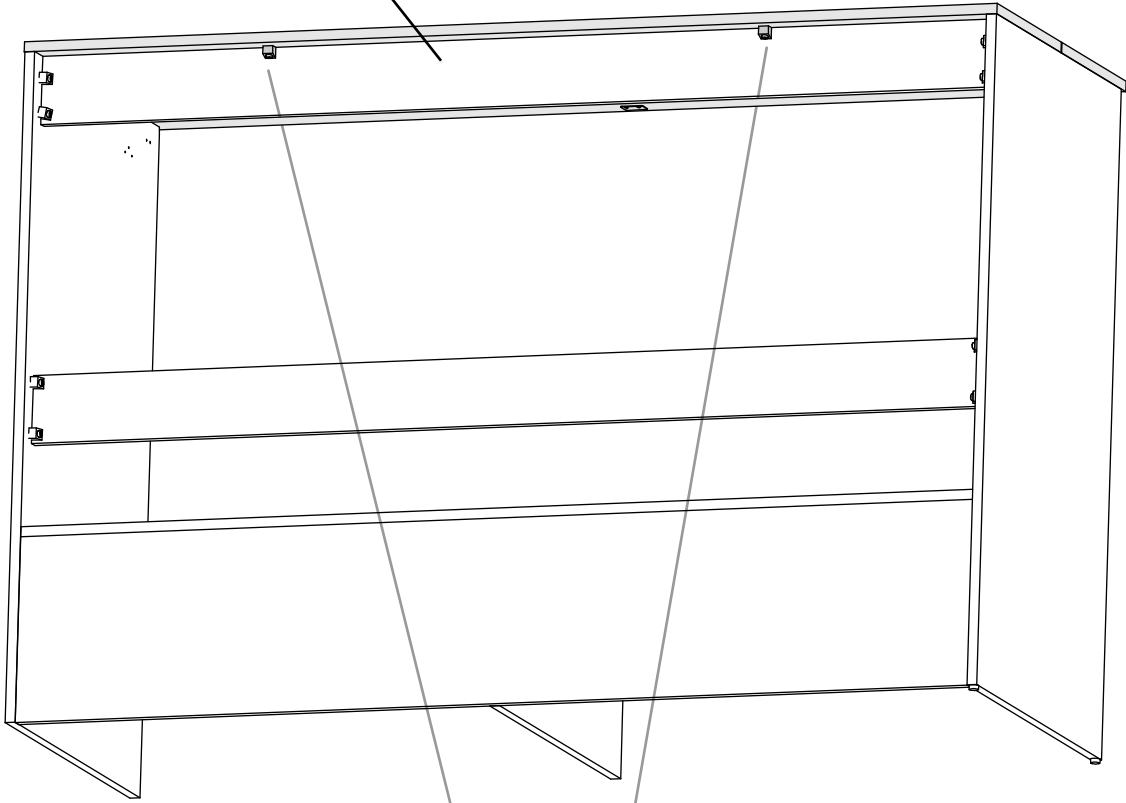

ASSEMBLAGE DU TIROIR / DRAWER ASSEMBLY

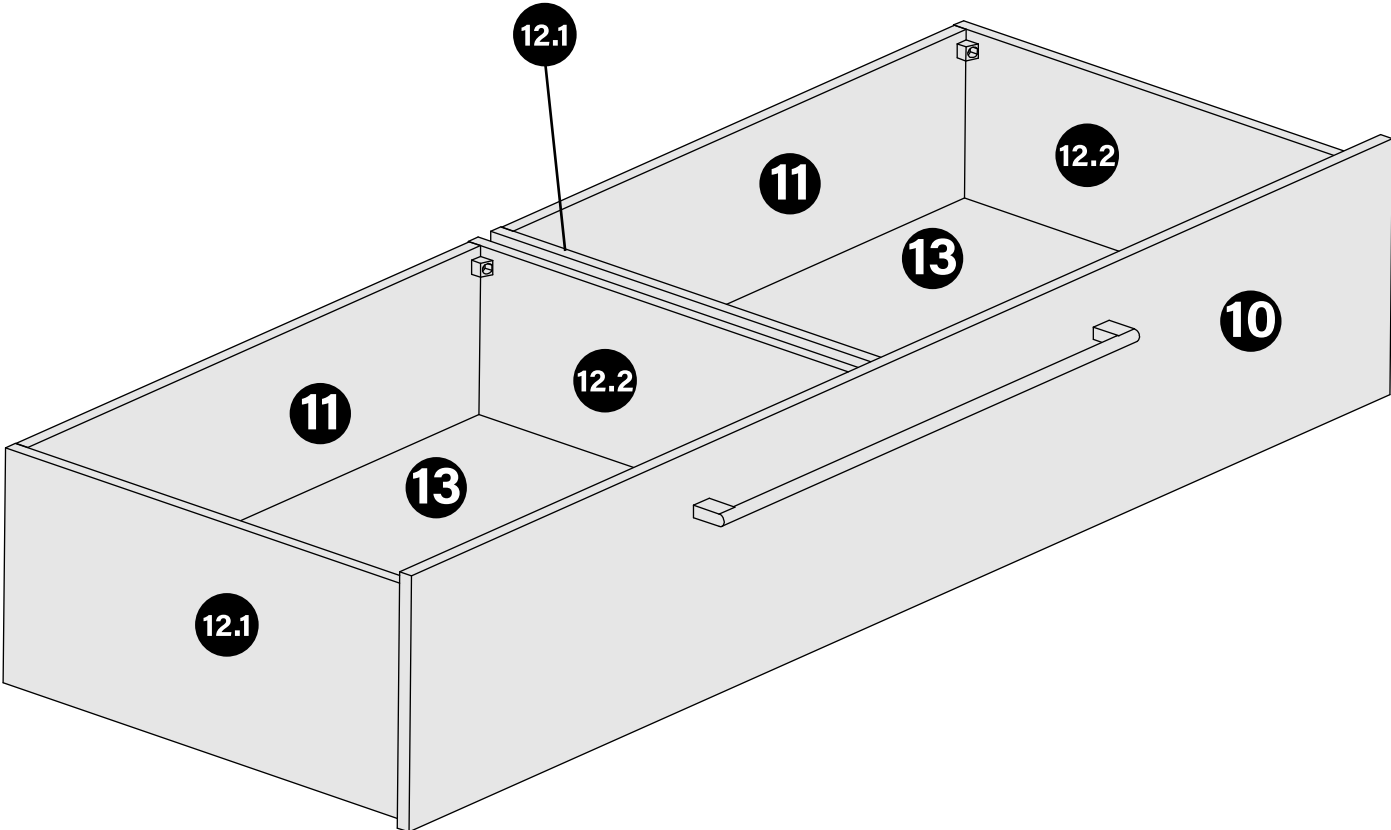

19

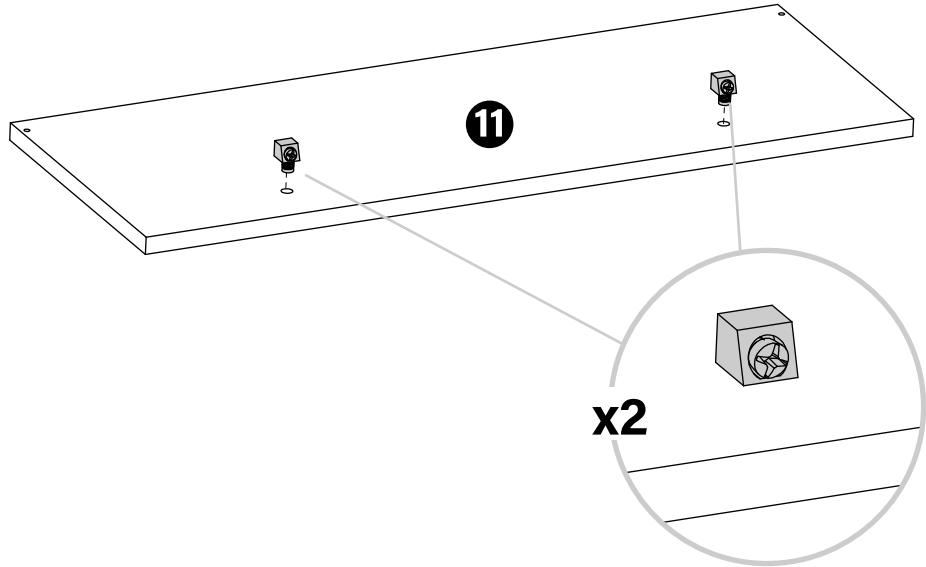

20

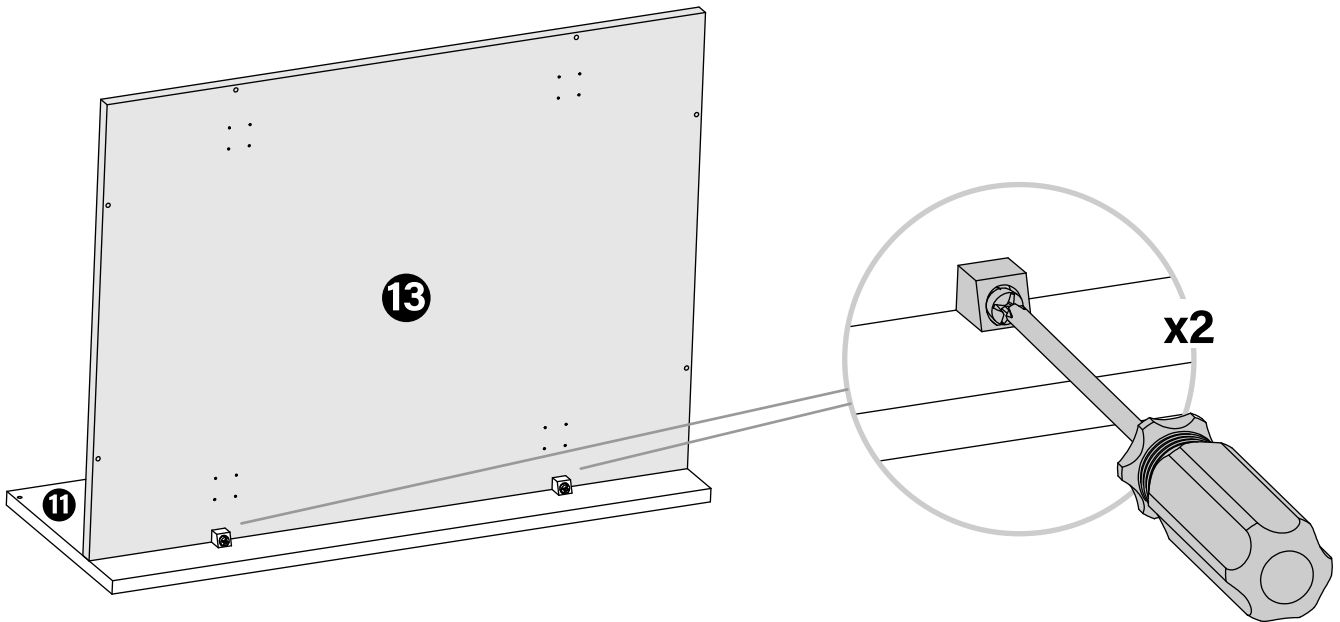

21

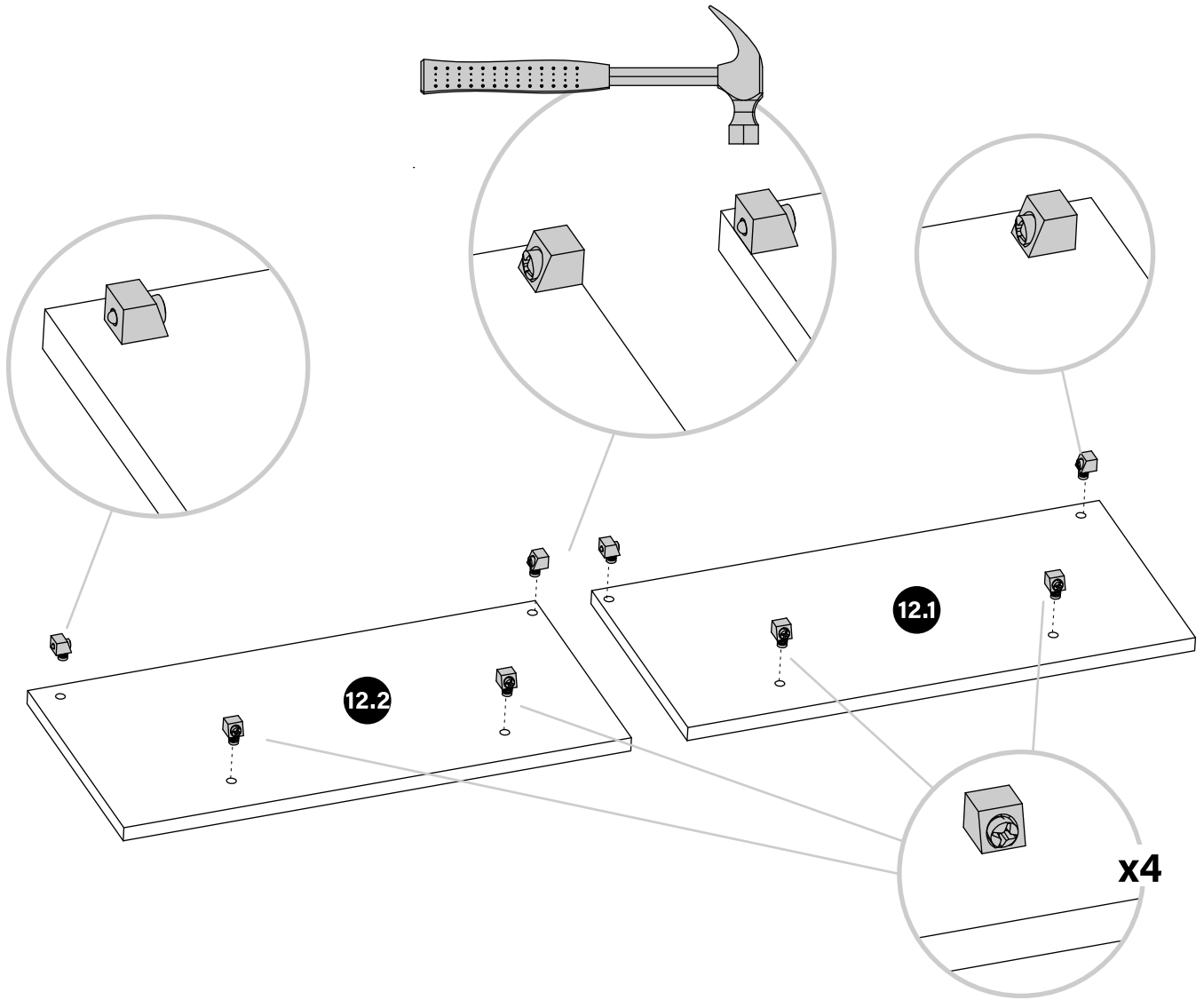

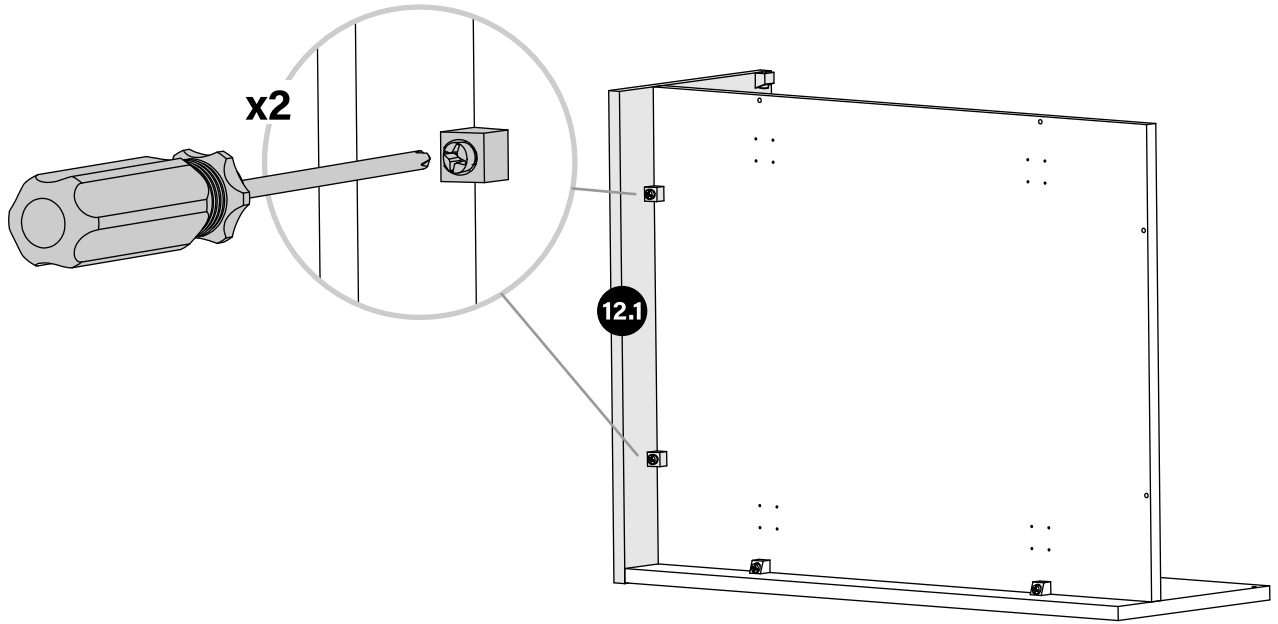

22

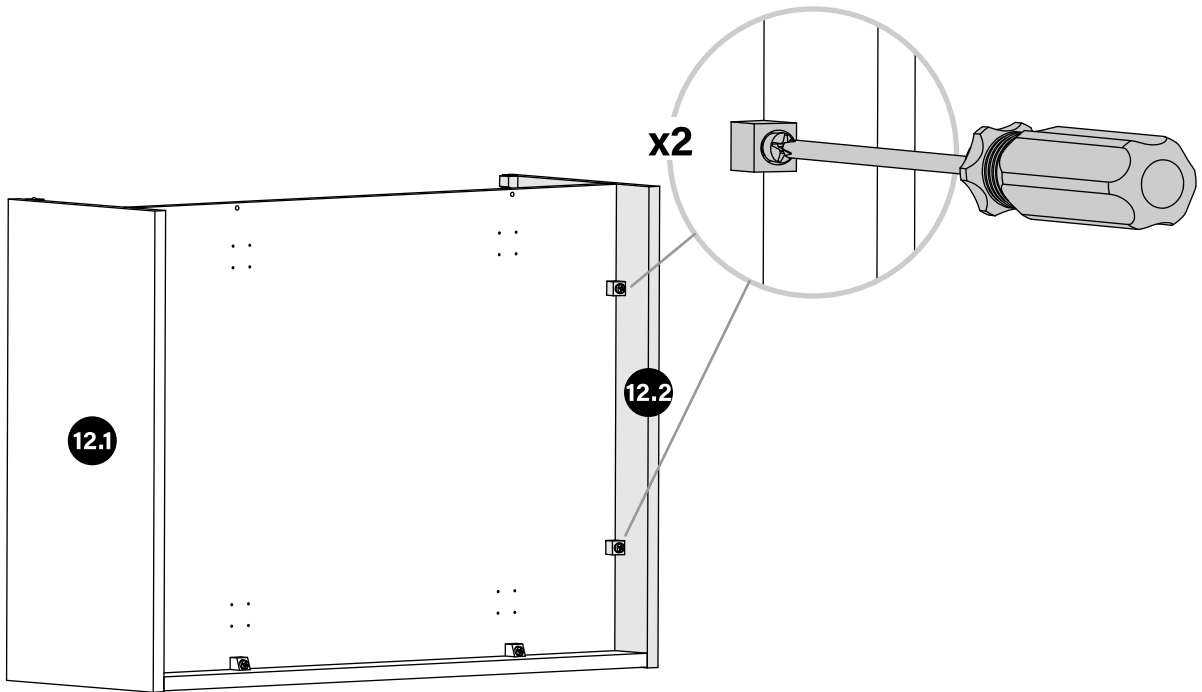

23

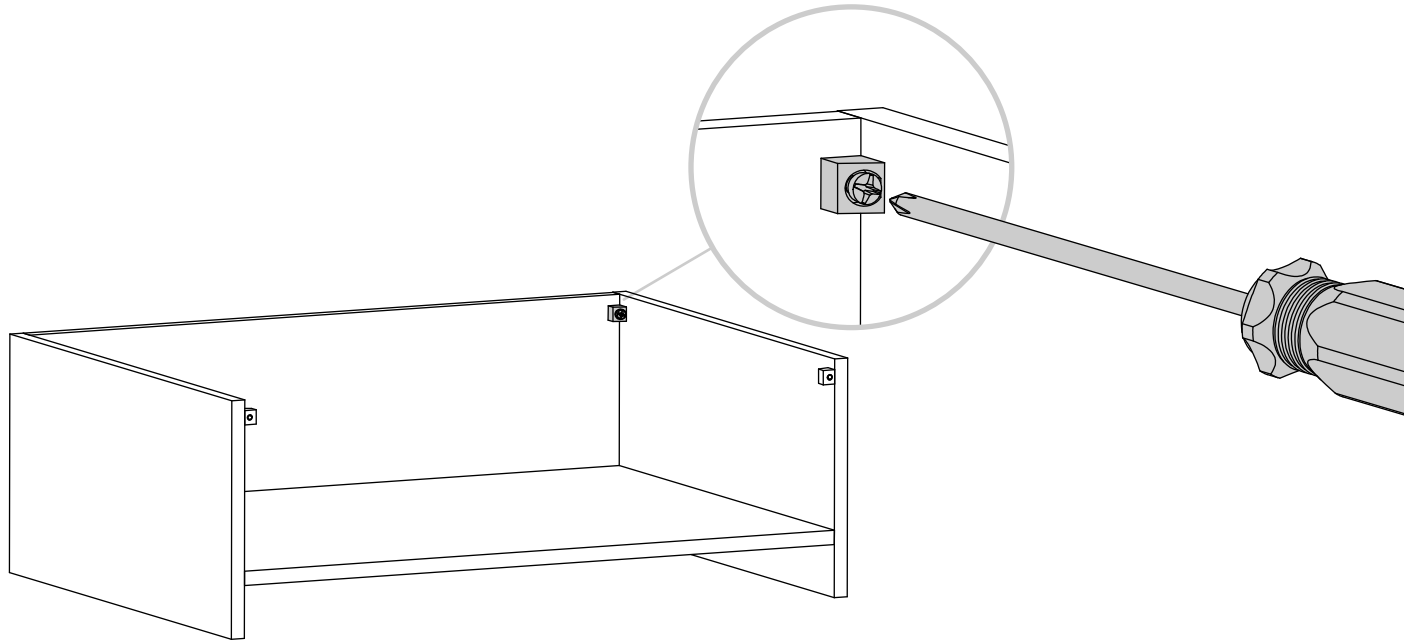
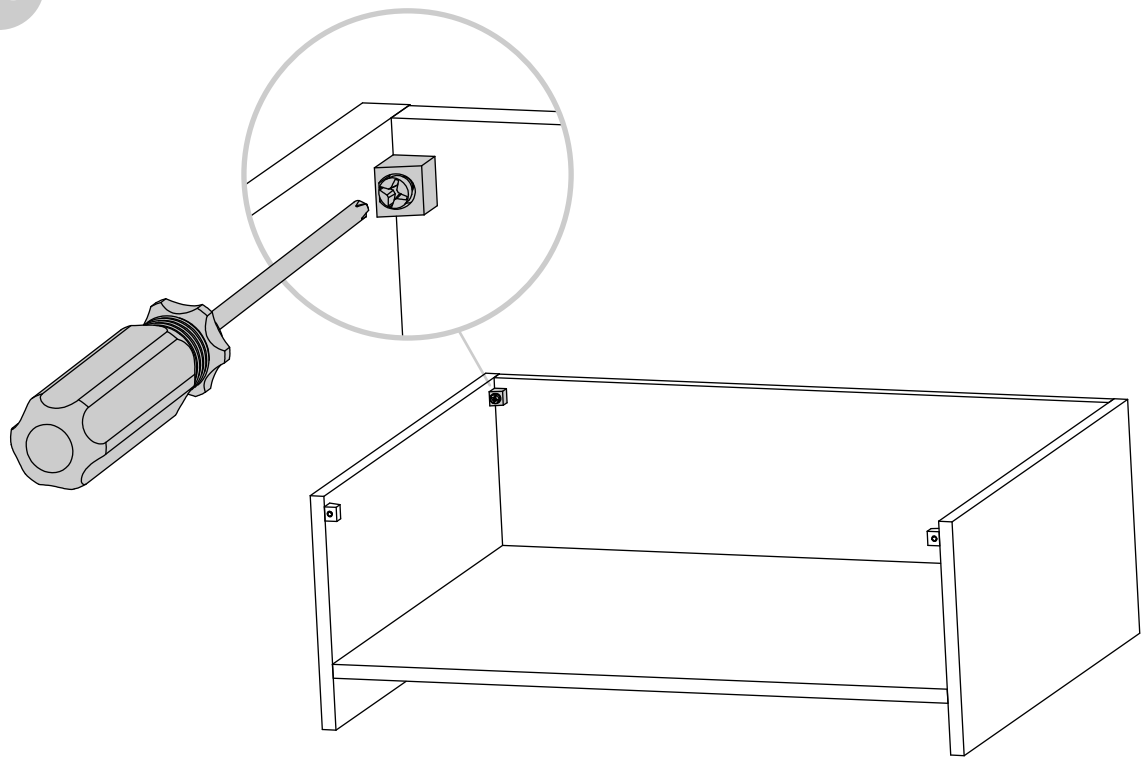

x2



25

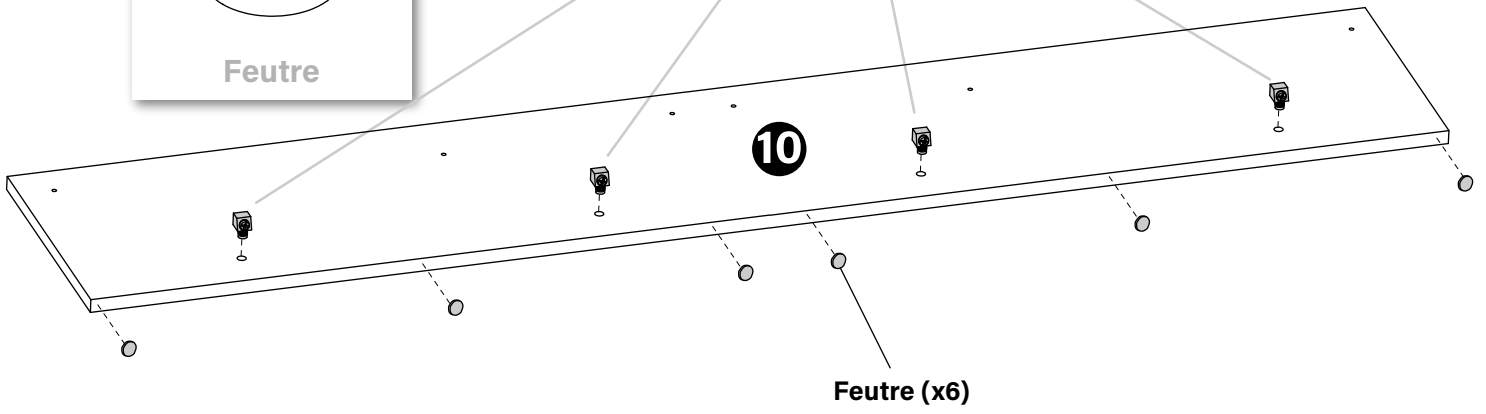
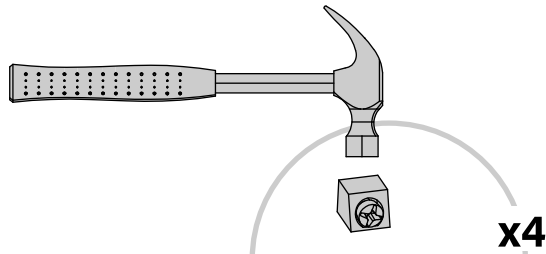

Feutre (x6)

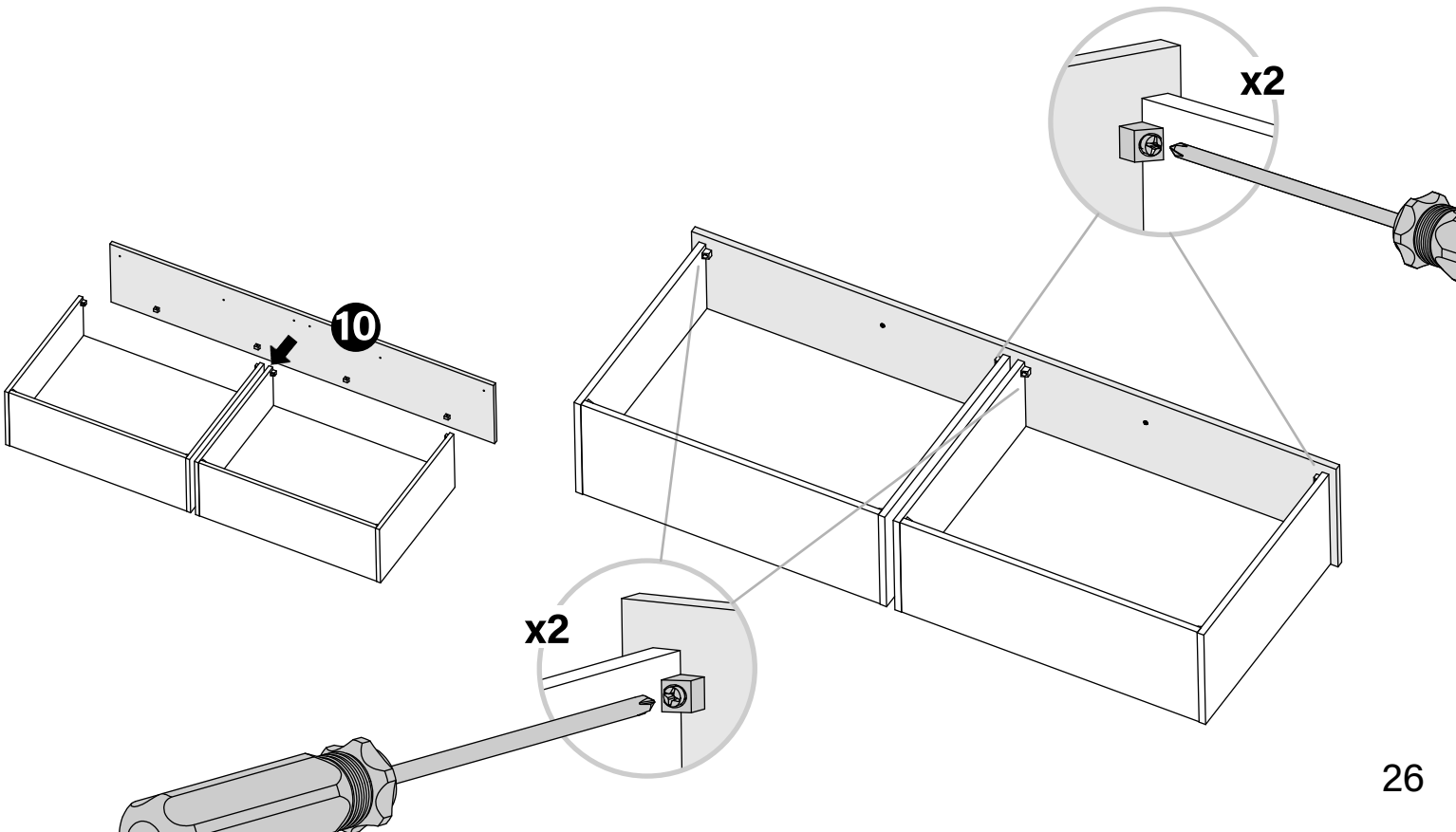

26

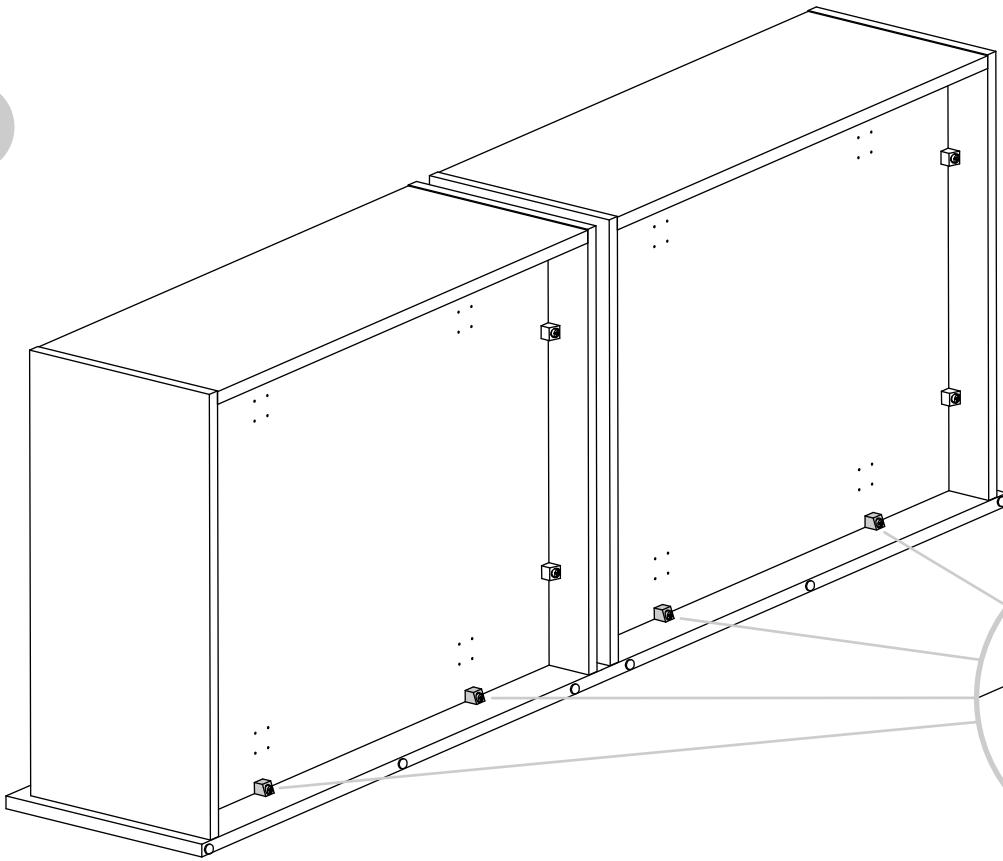

x4

27

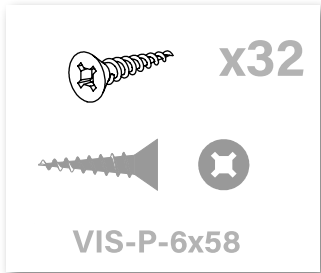

VIS-P-6x58

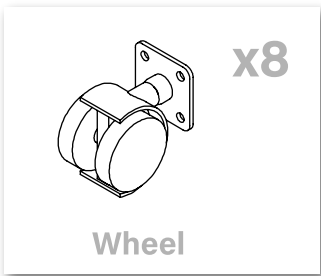

x8

Wheel

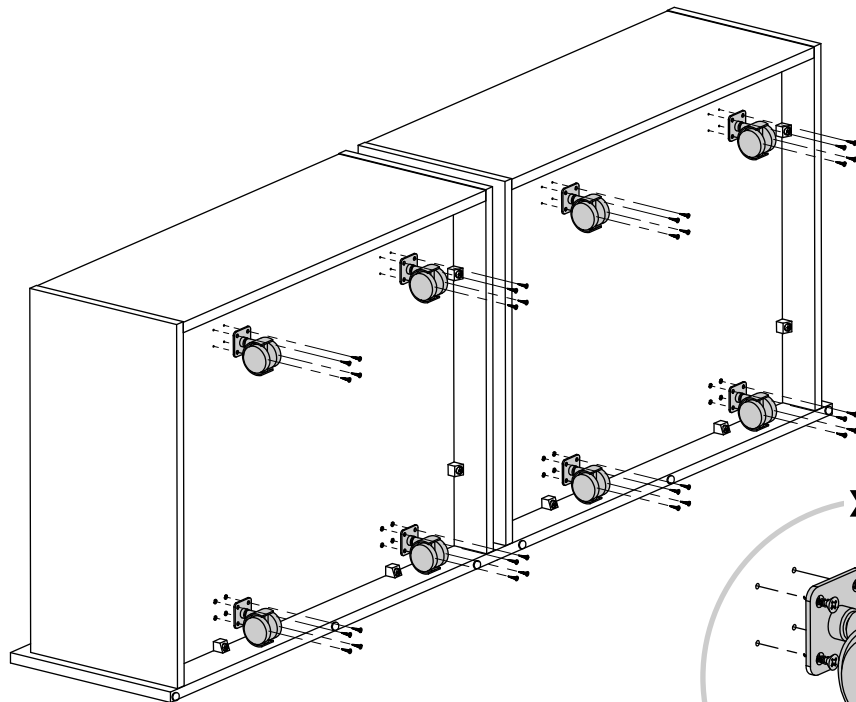

x8

28

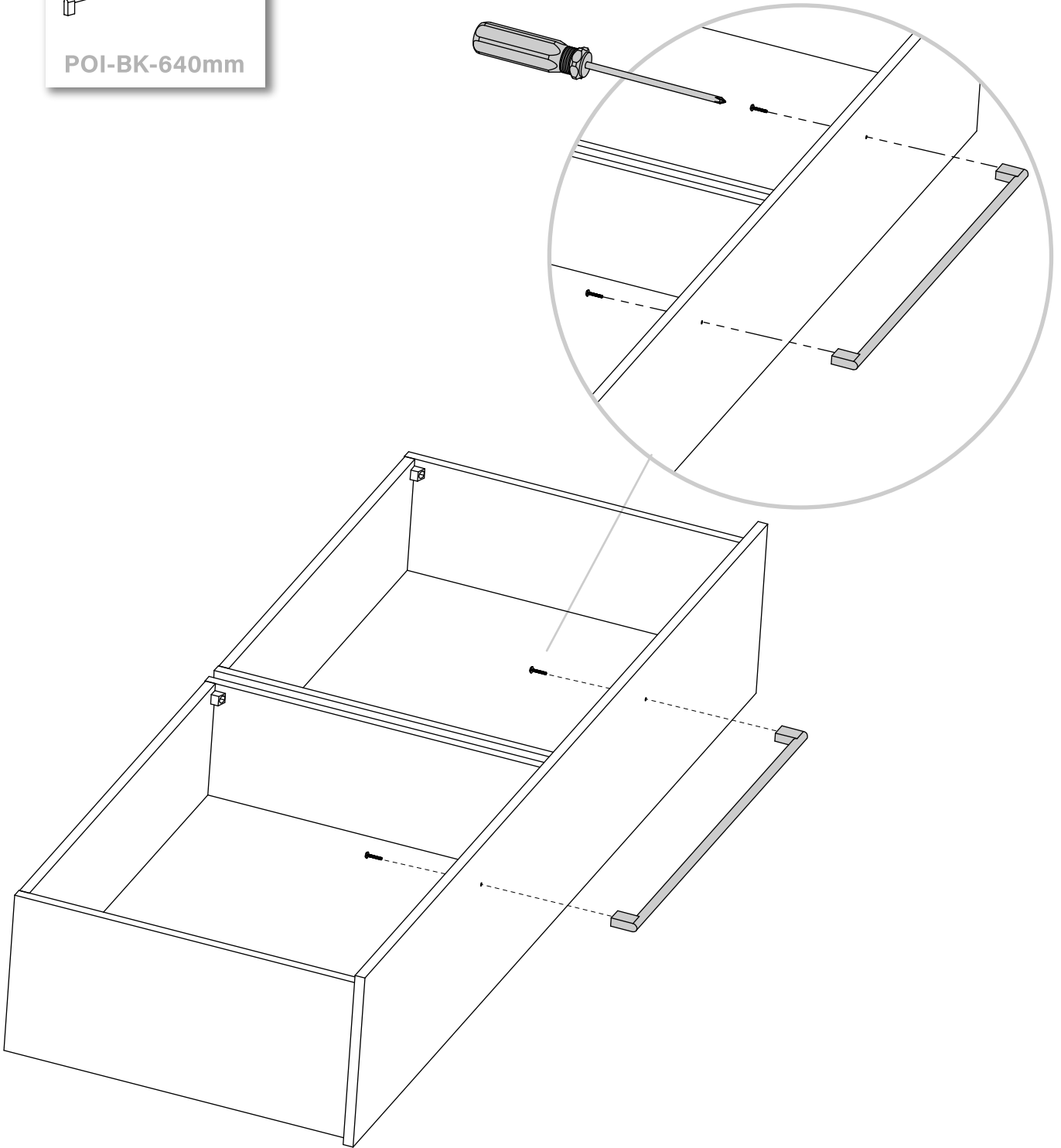
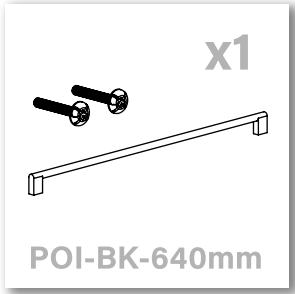

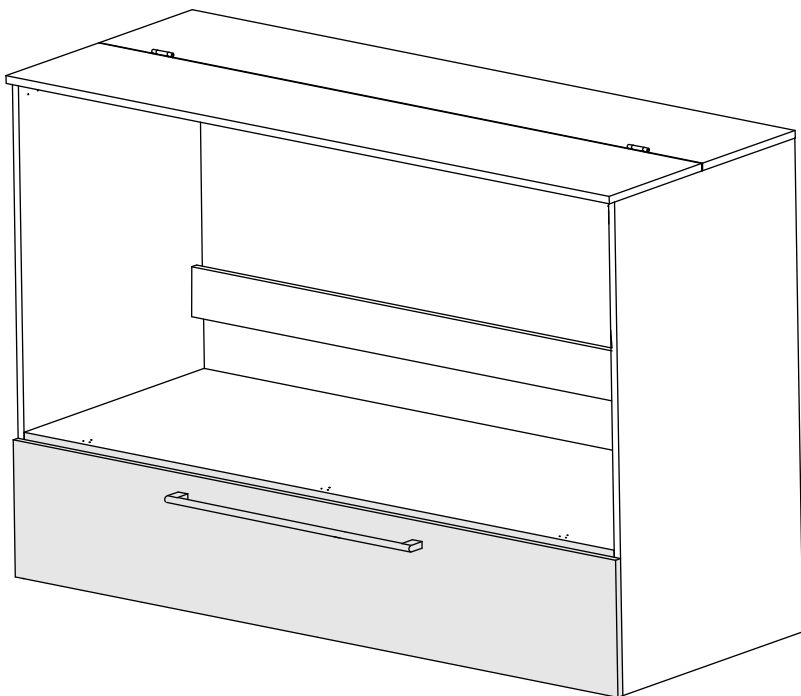
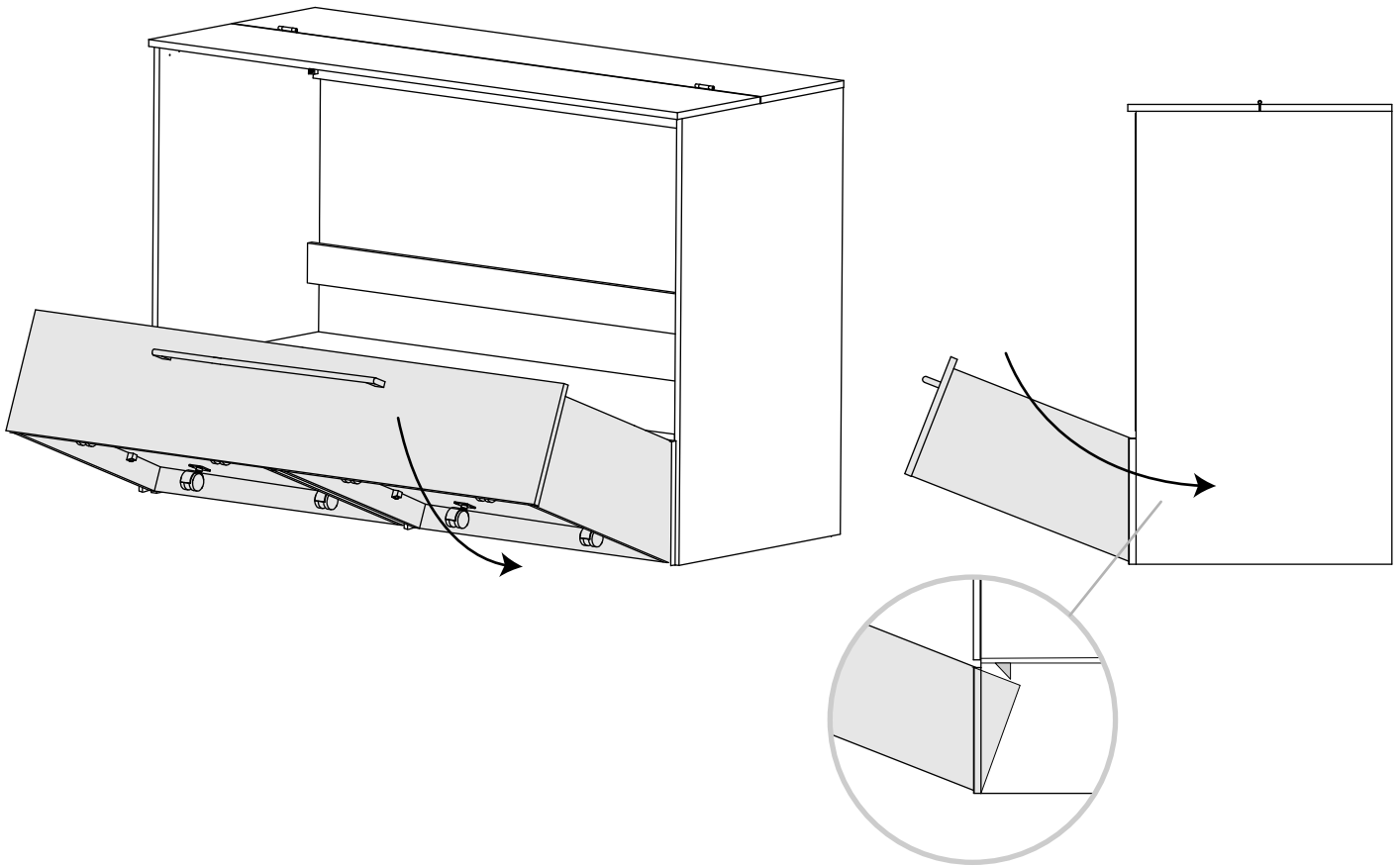

ASSEMBLAGE DES PORTES / DOORS ASSEMBLY

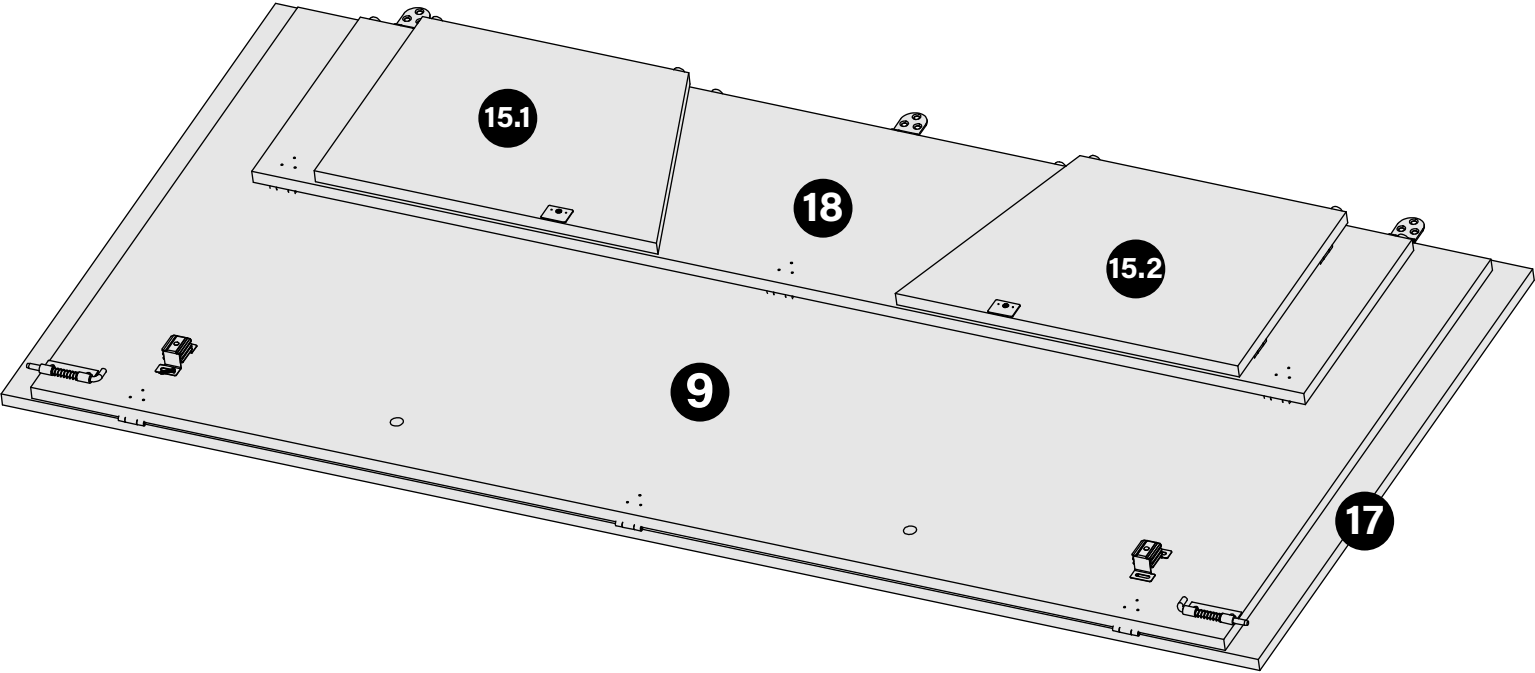

32

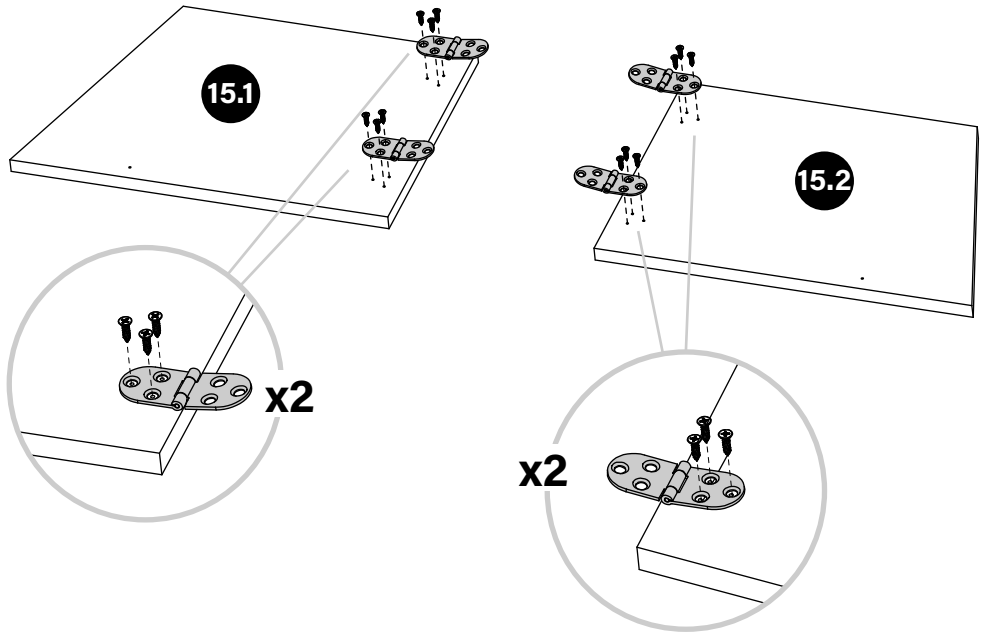
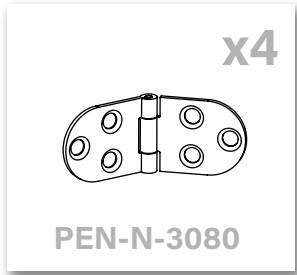

33

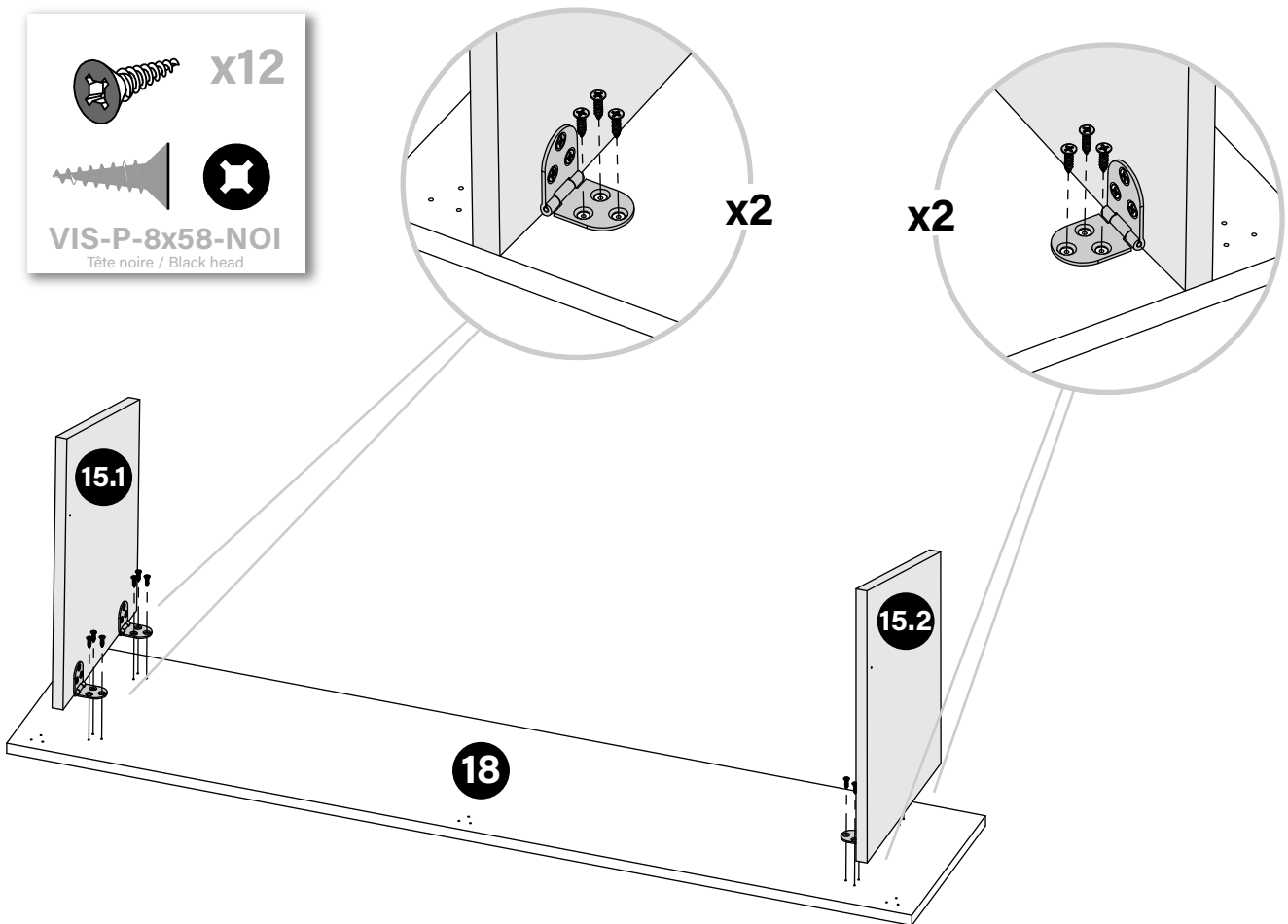

34

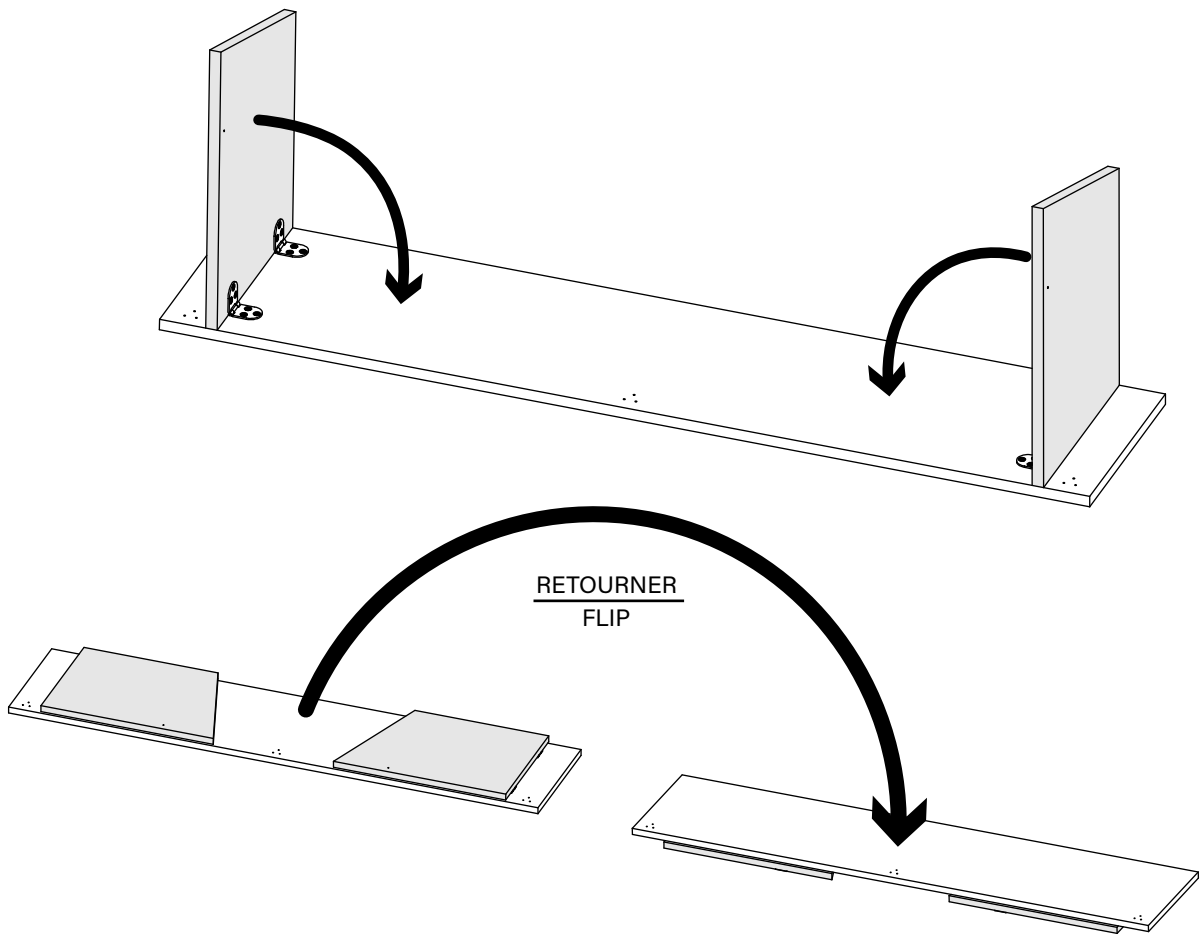

35

x9

VIS-P-8x58-NOI
Tête noire / Black head

x3

PEN-N-3080

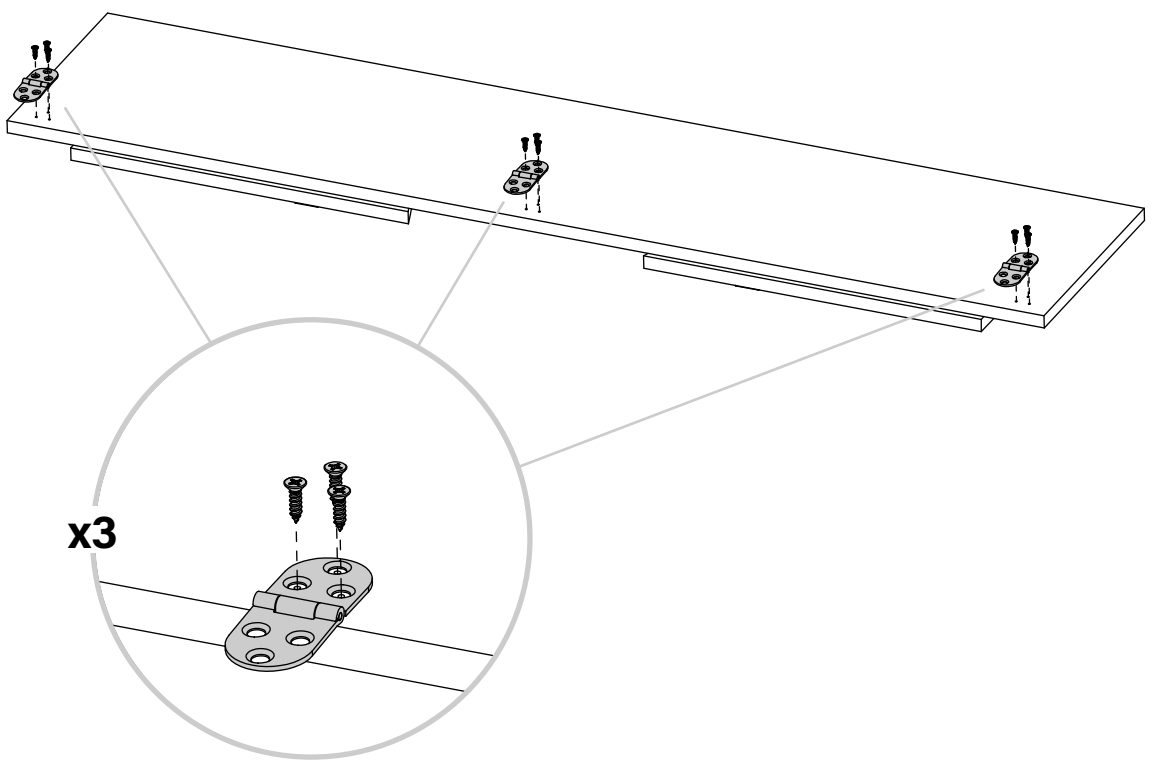

36

x18

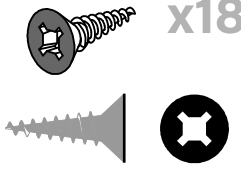

VIS-P-8x58-NOI
Tête noire / Black head

x6

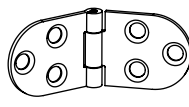

PEN-N-3080

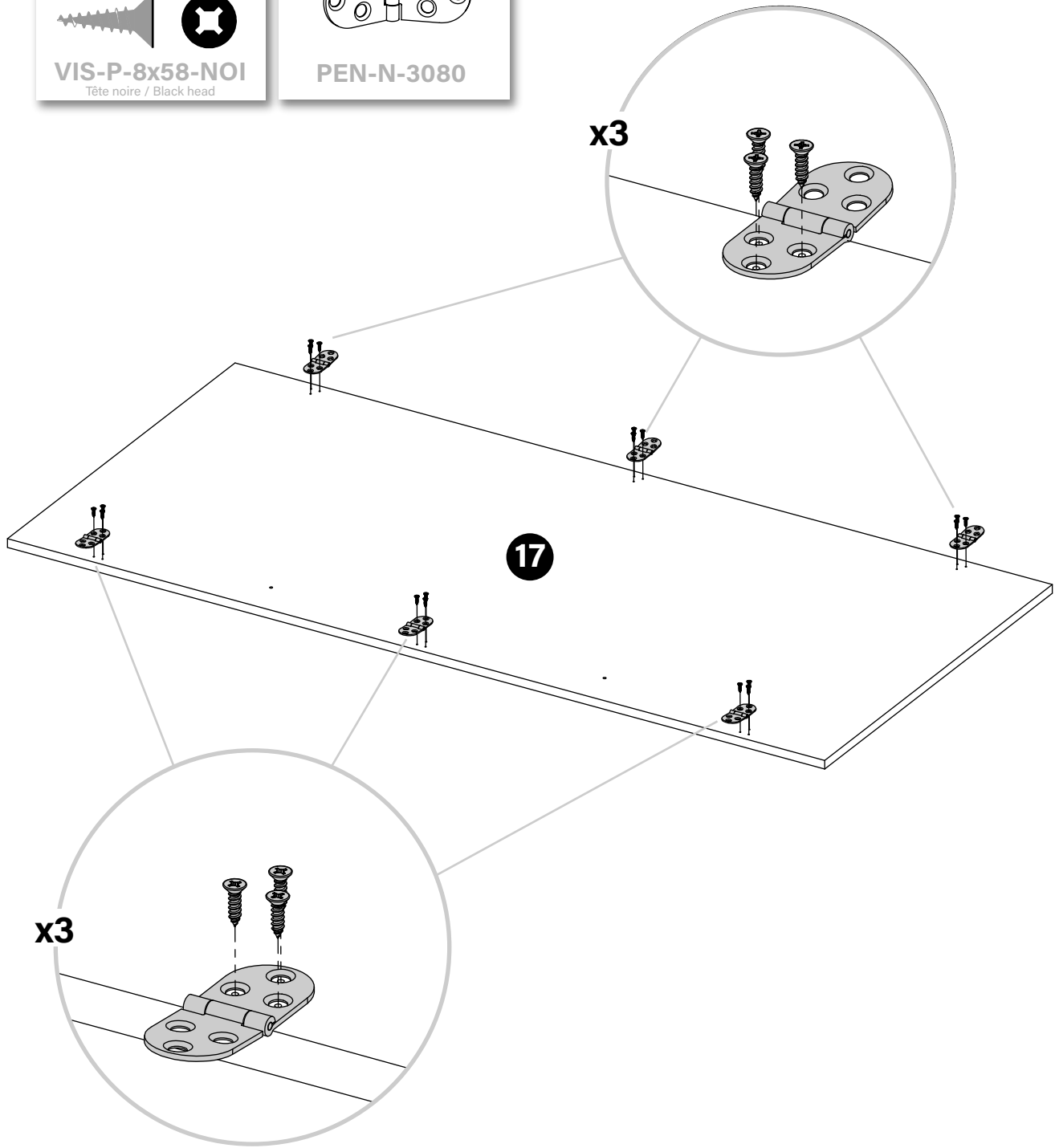

37

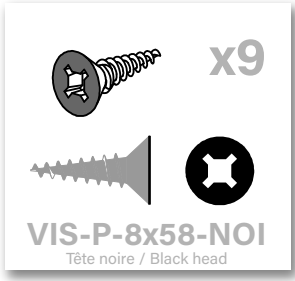

Ces trous doivent être de ce côté.
These holes should be on this side.

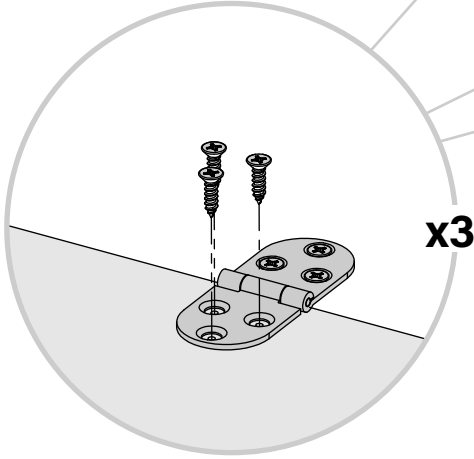
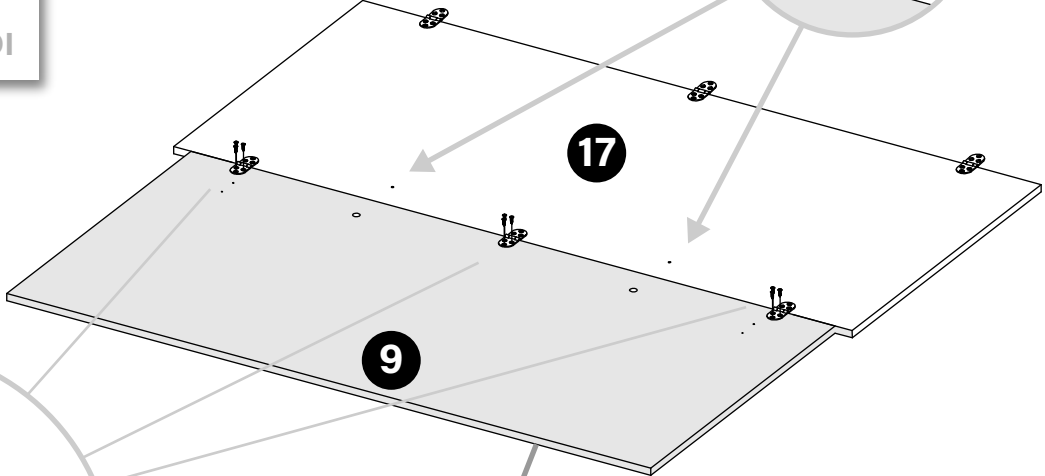
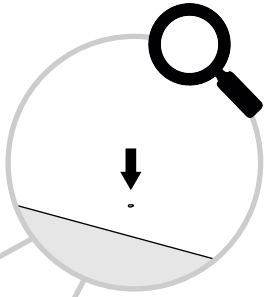

Assurez-vous que le panneau est sur le bon côté.
Make sure the panel is on the correct side.



Ce côté vers le haut
This side up

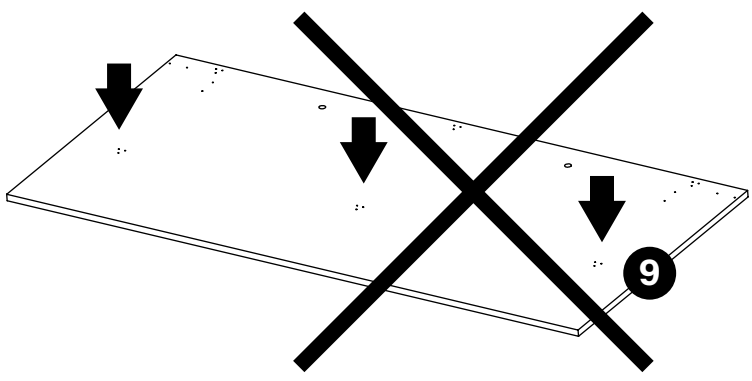
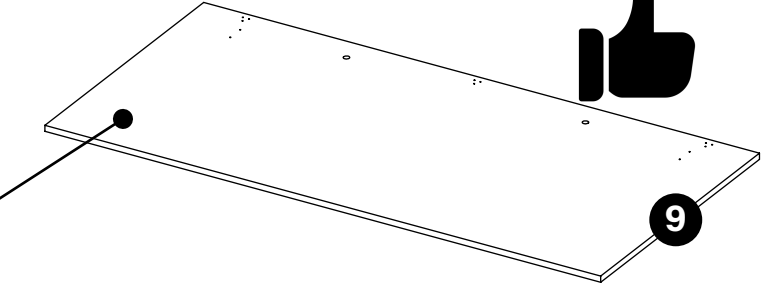

38

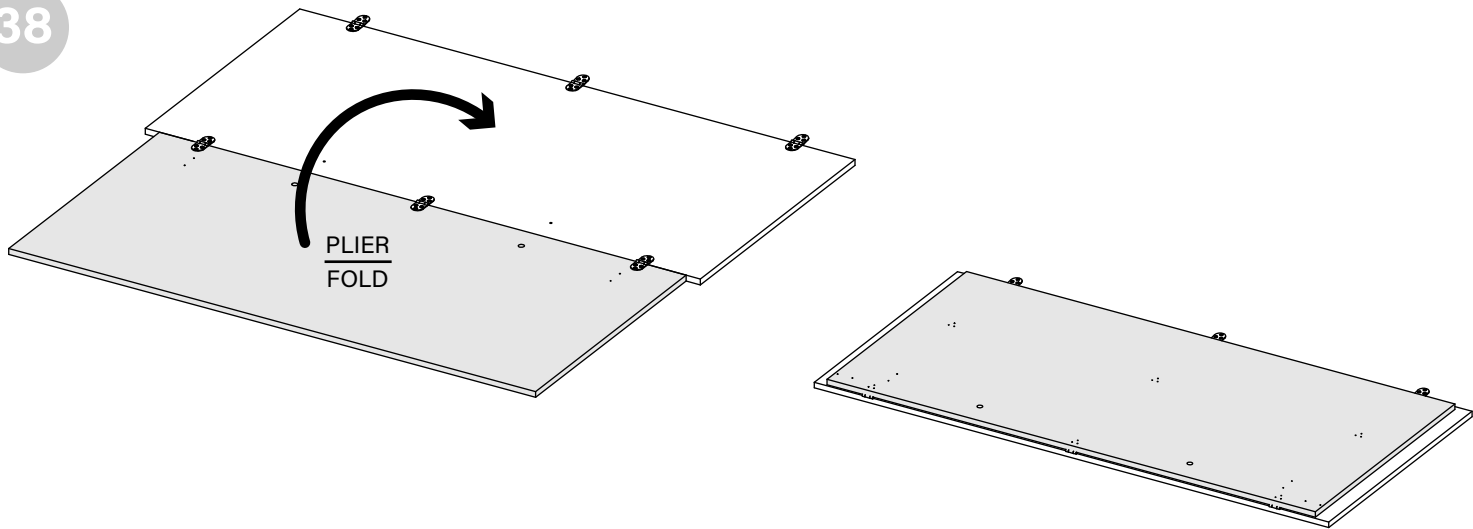

39

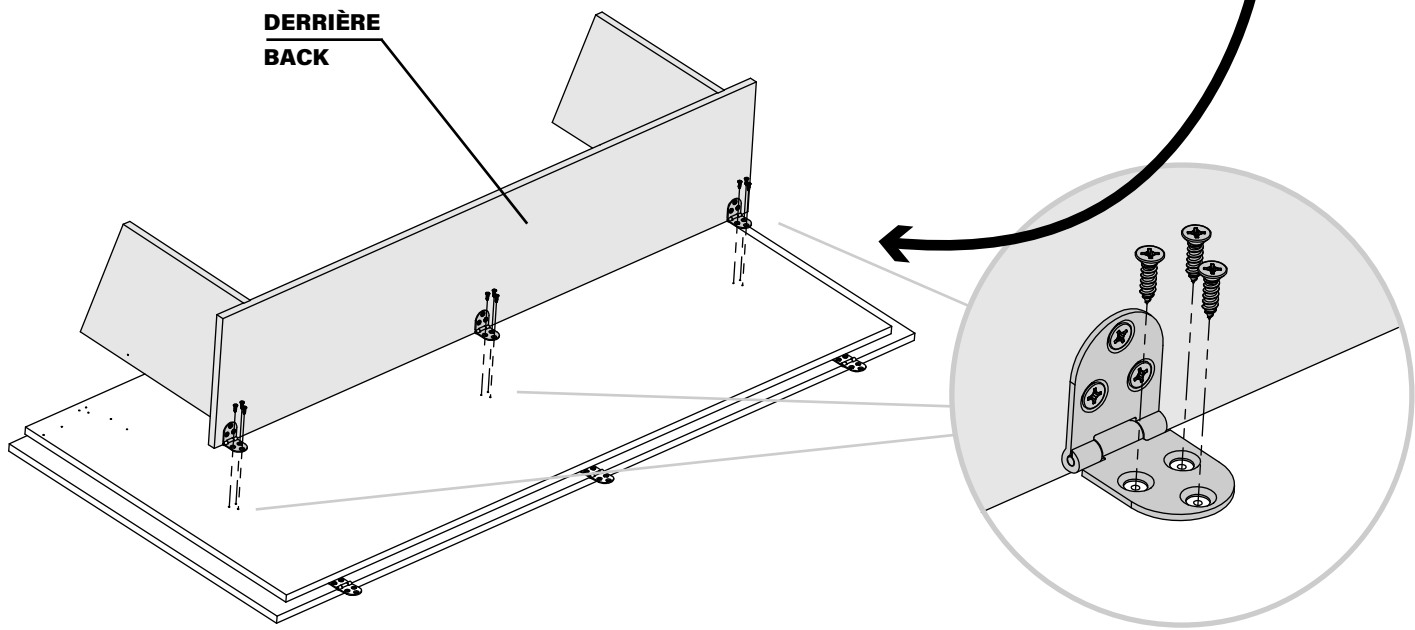
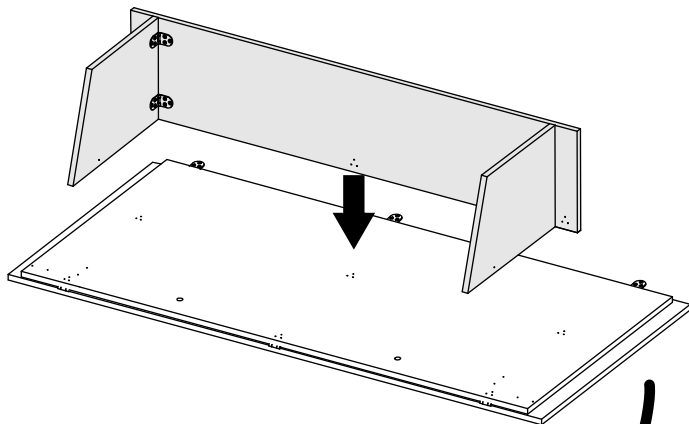

40

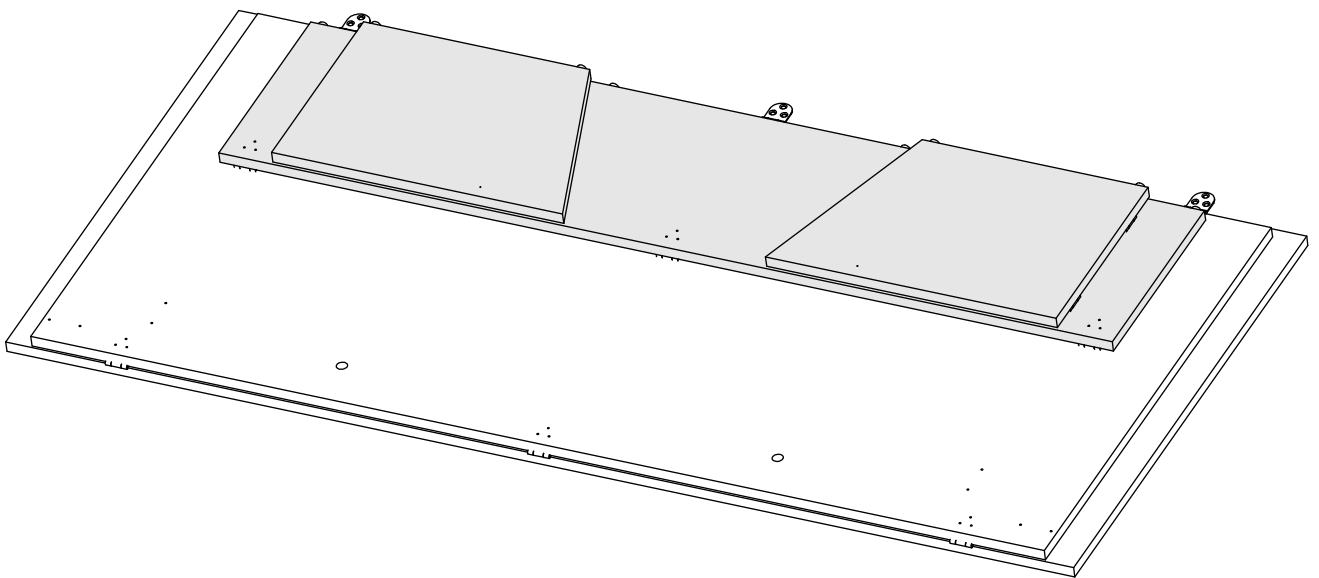
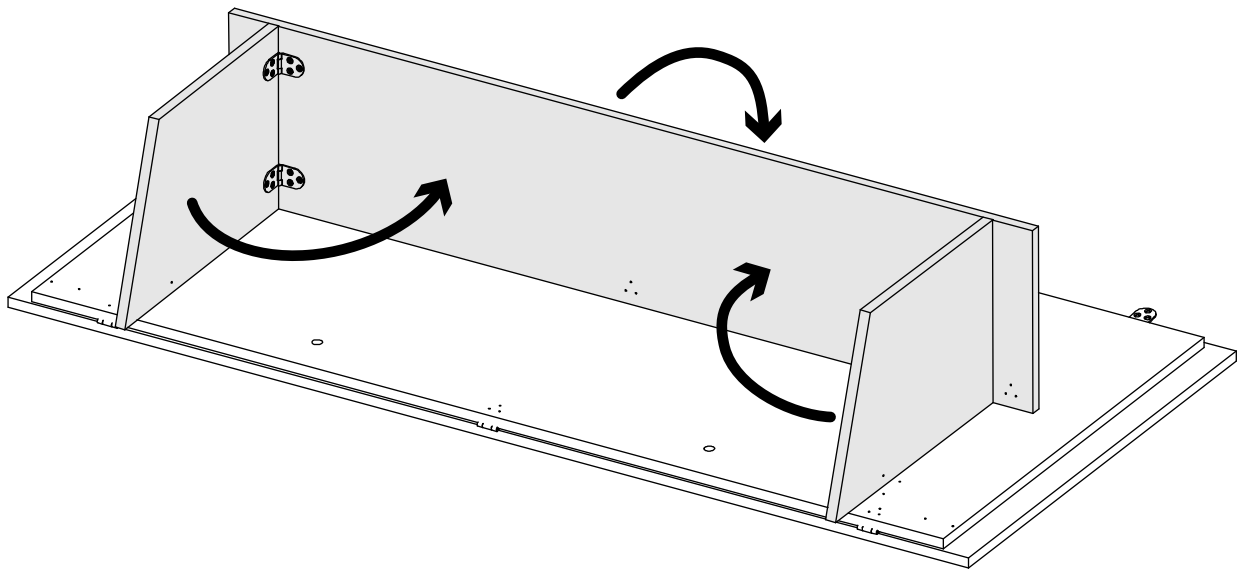

41

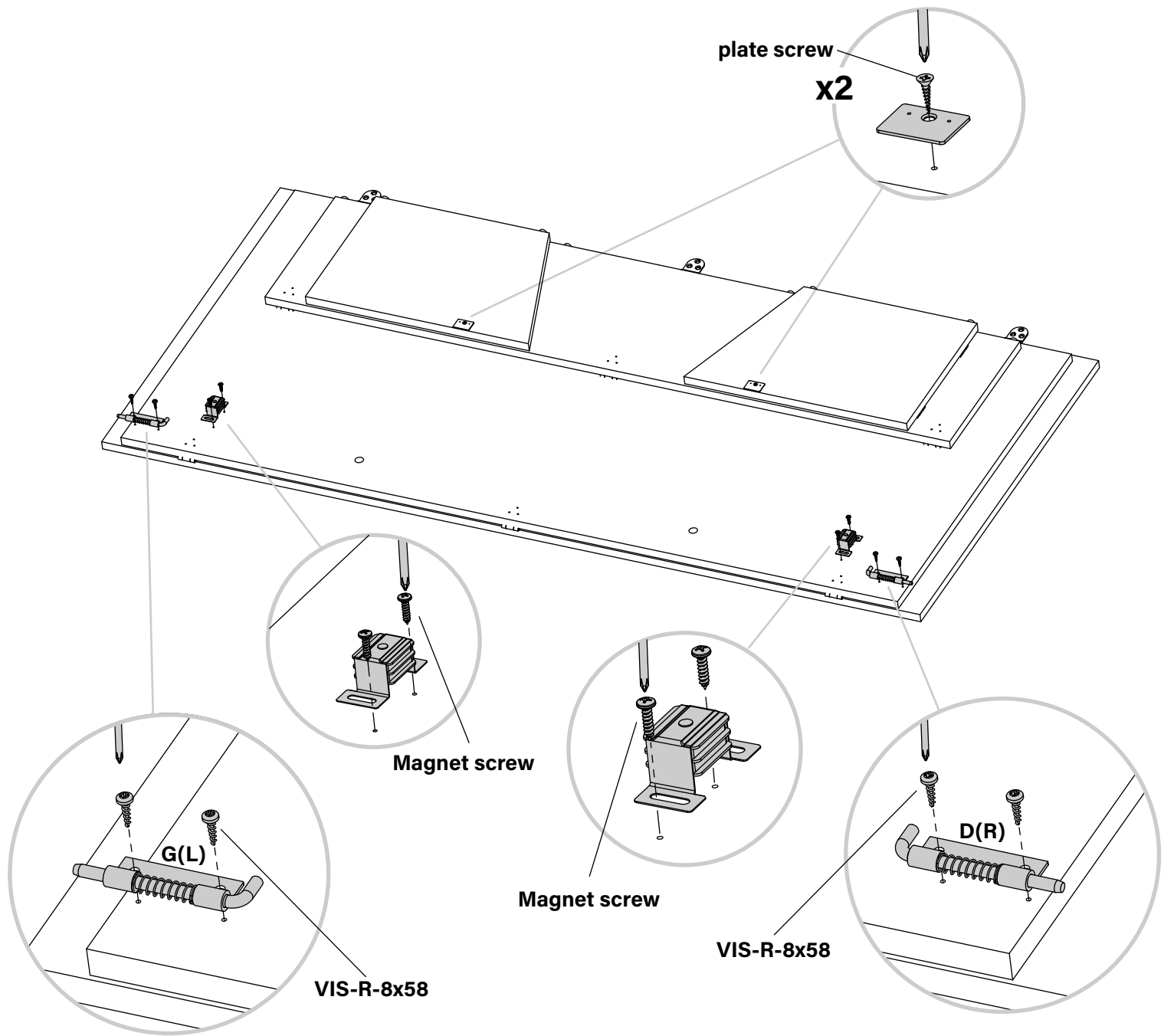
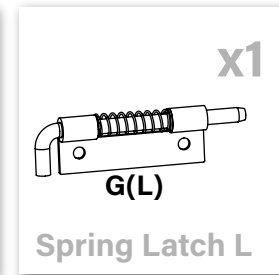
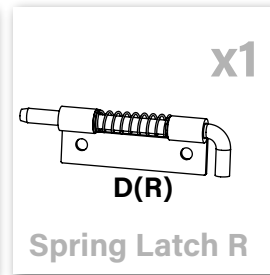
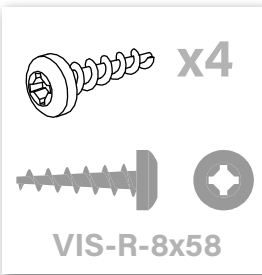
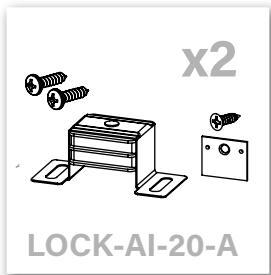

42

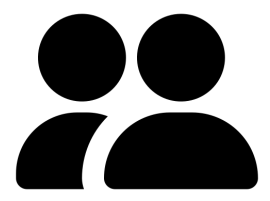
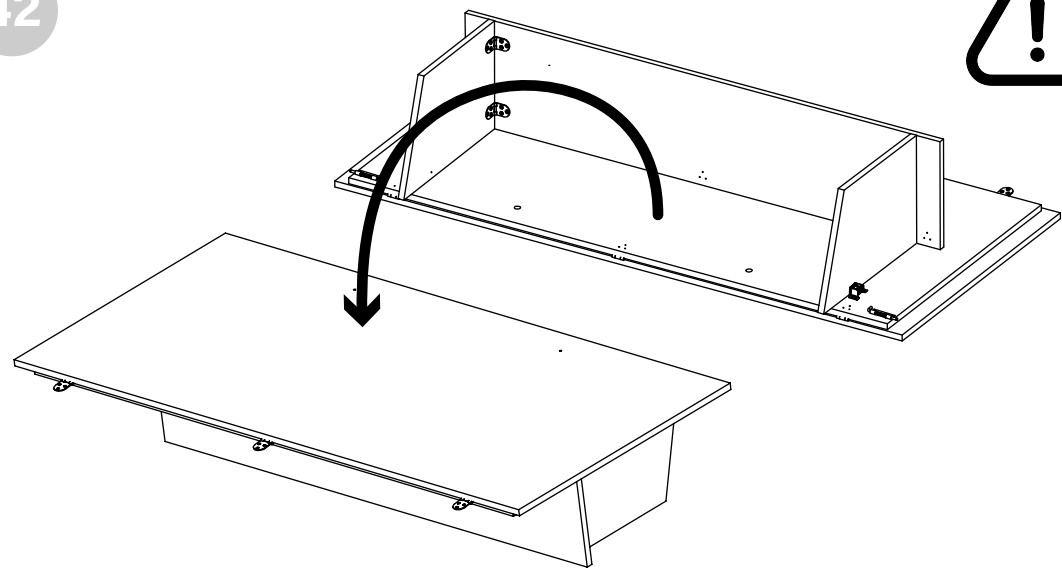

2 personnes requises pour retourner l'assemblage

2 people required to flip the assembly

43

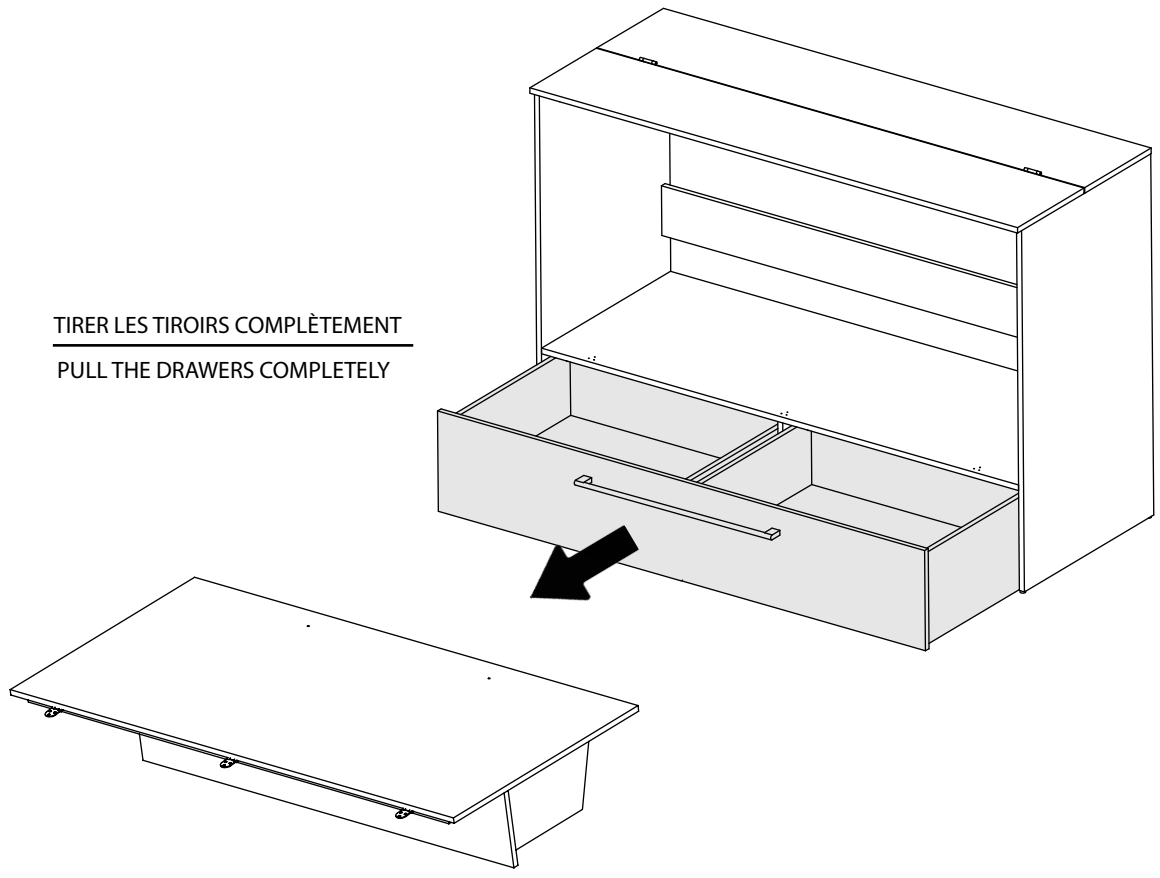

TIRER LES TIROIRS COMPLÈTEMENT
PULL THE DRAWERS COMPLETELY

44

DÉPLIER
UNFOLD

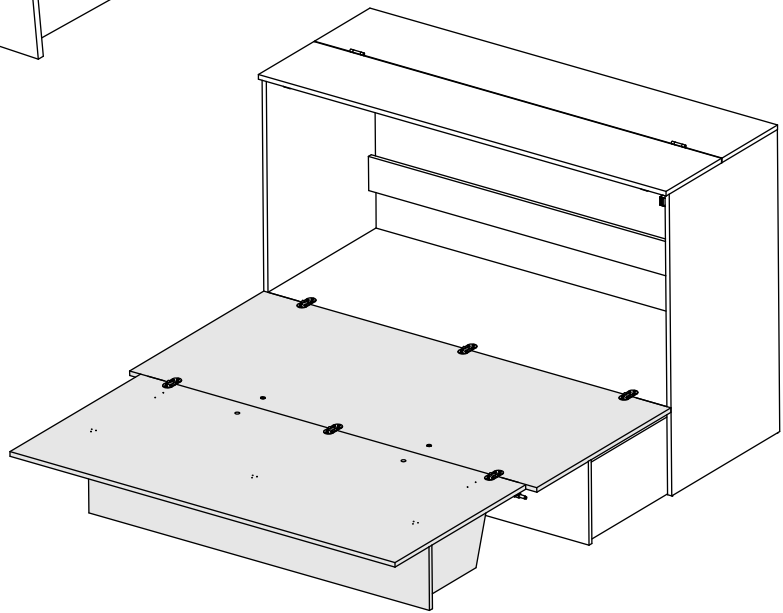
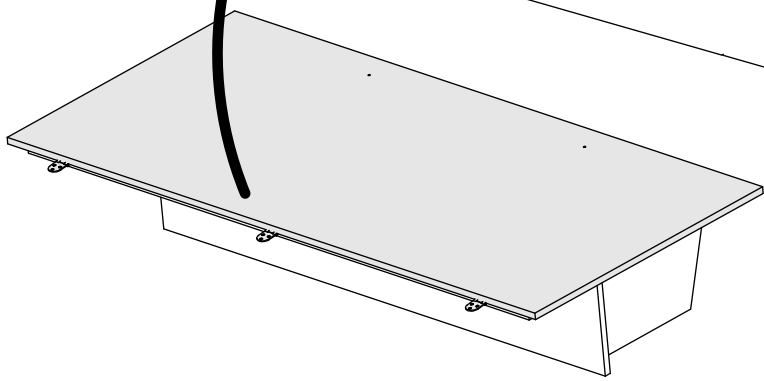
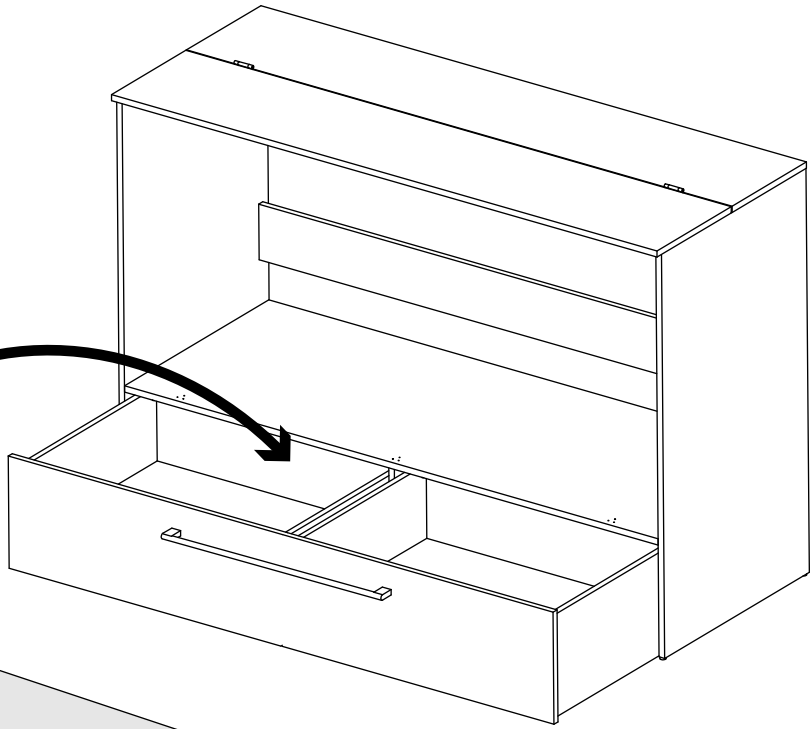

45

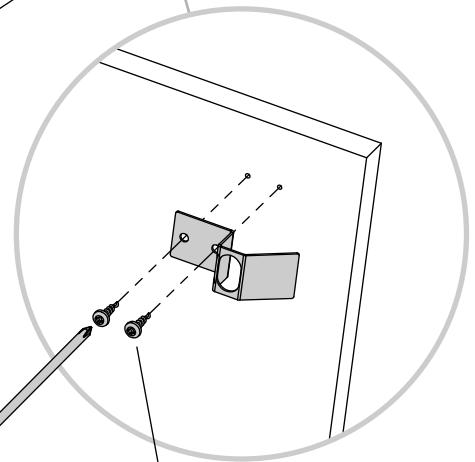
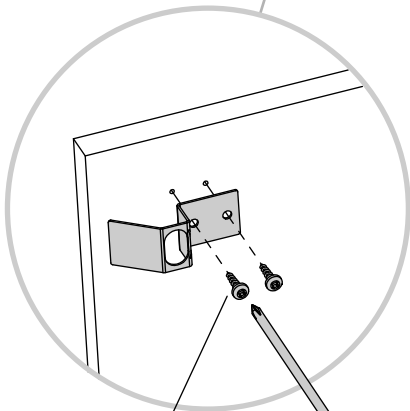
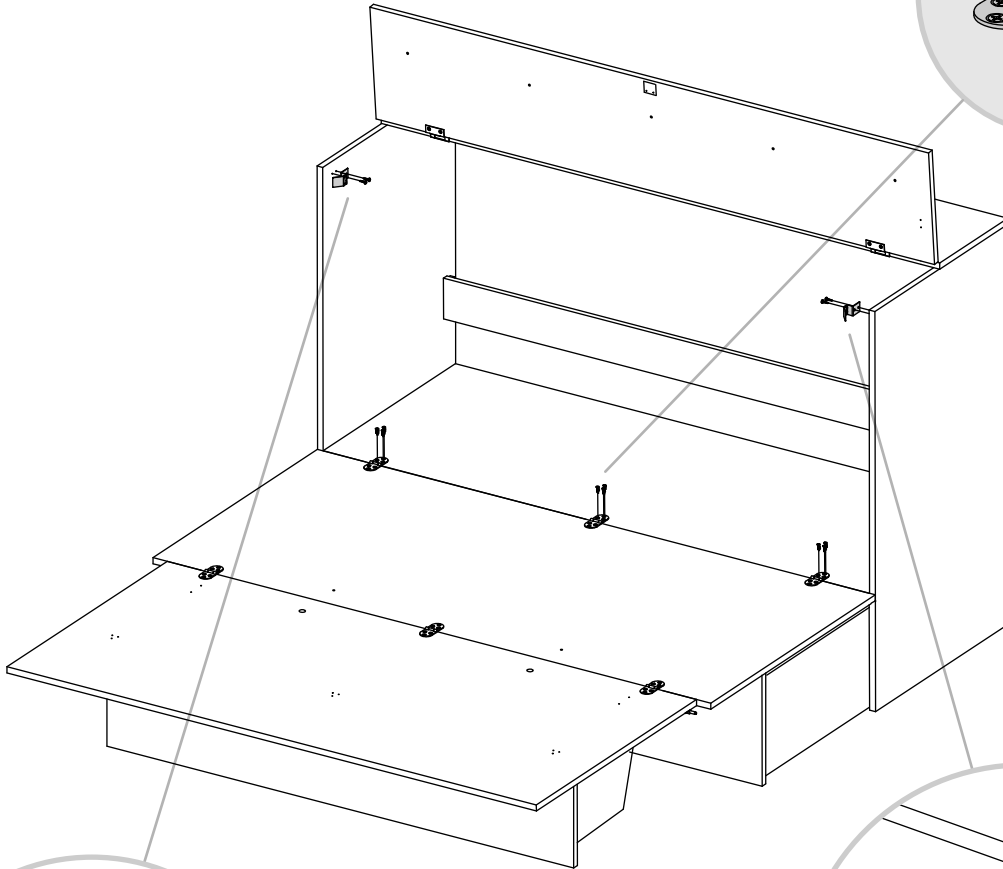
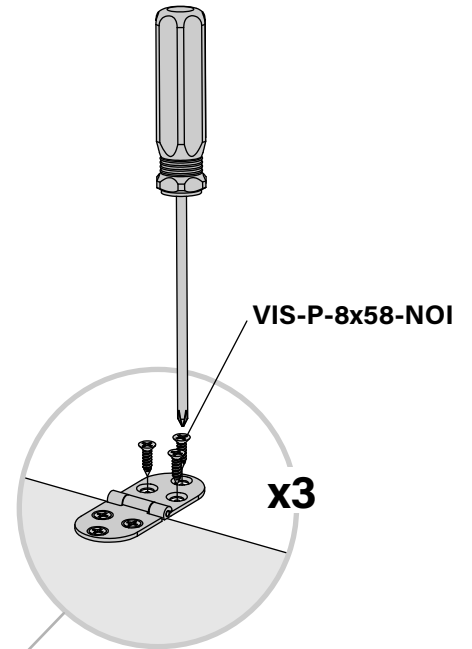
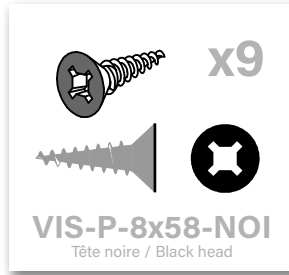
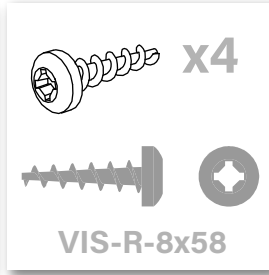
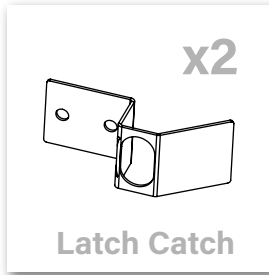

46

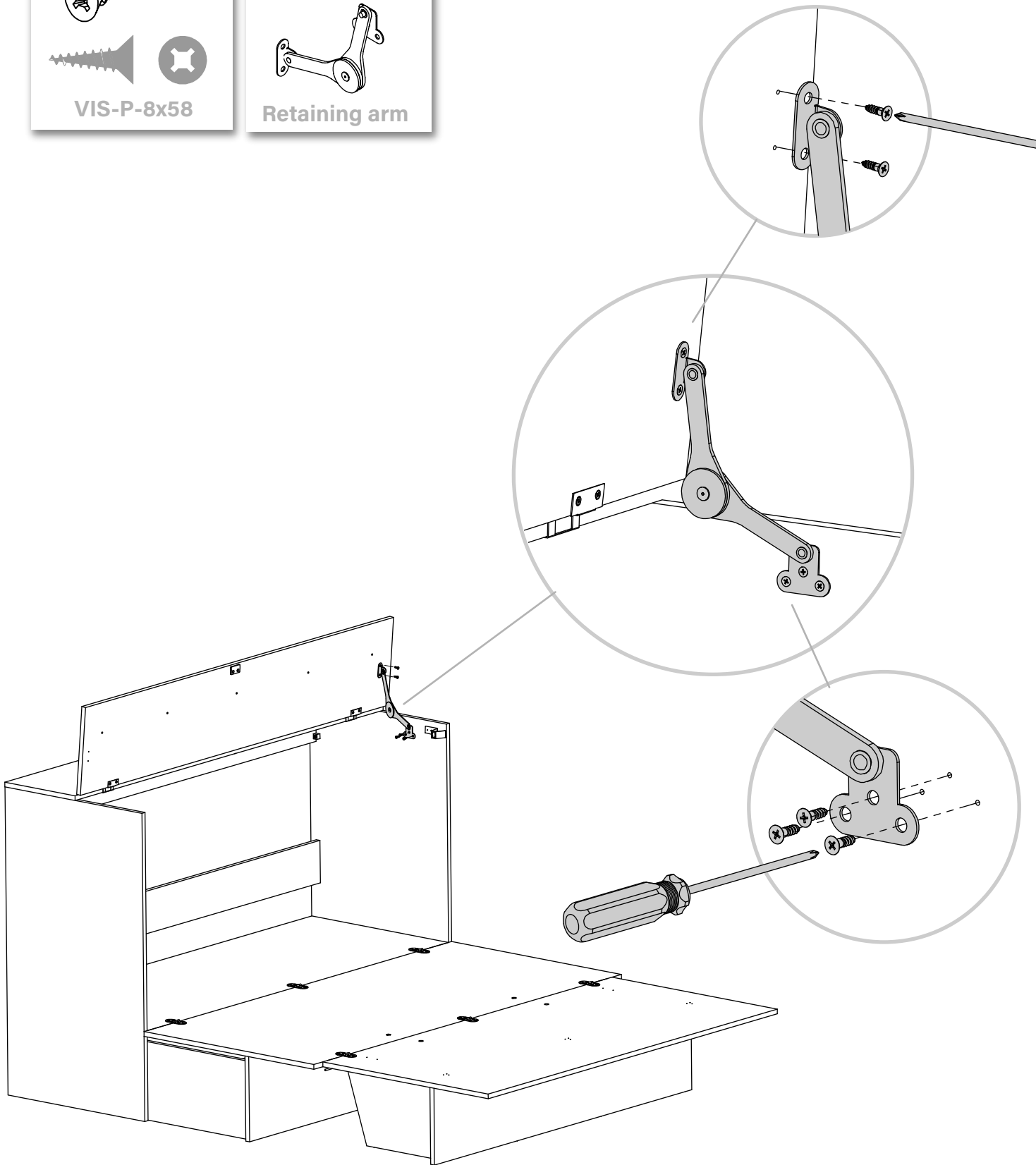
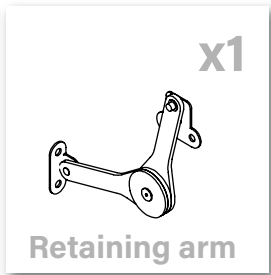
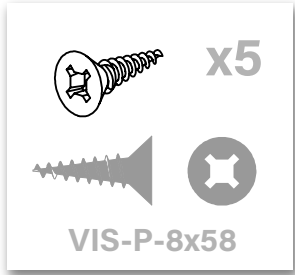

47

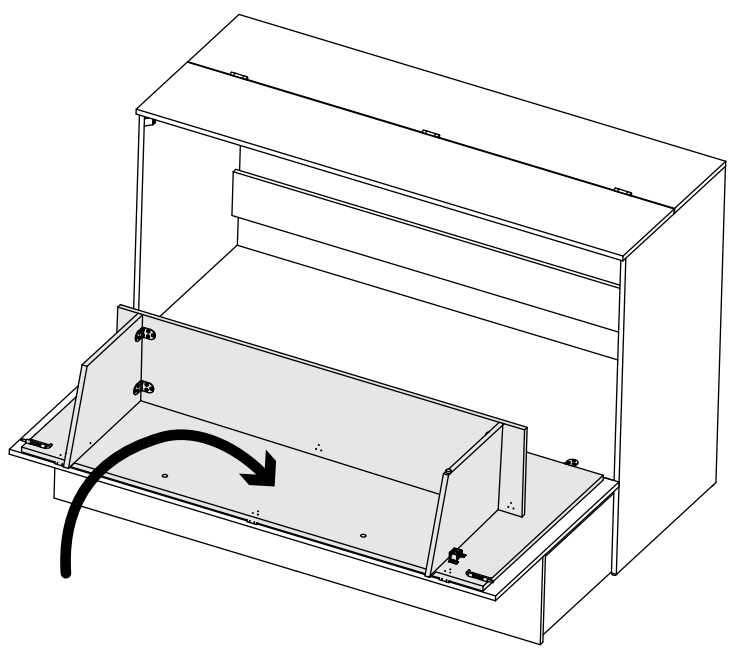

48

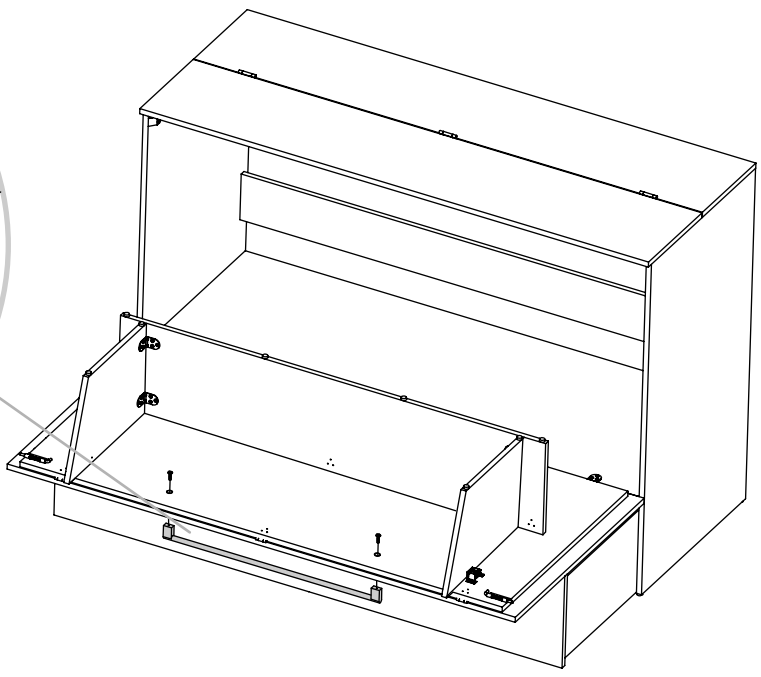
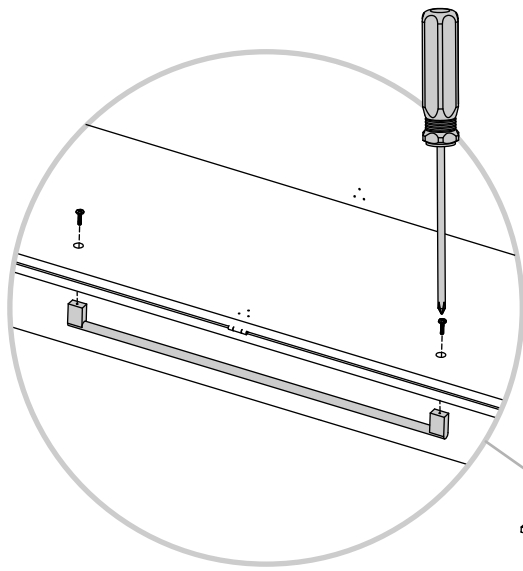
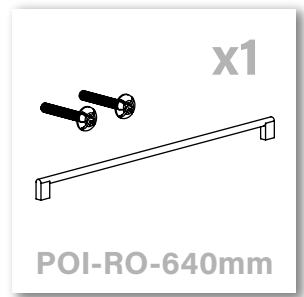

FERMETURE / CLOSING (1/3)

49

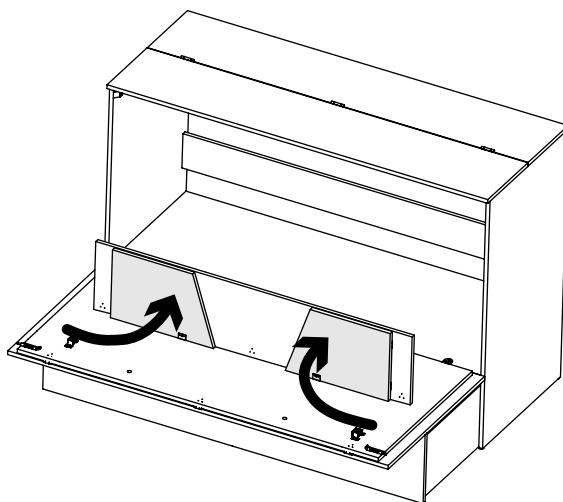

50

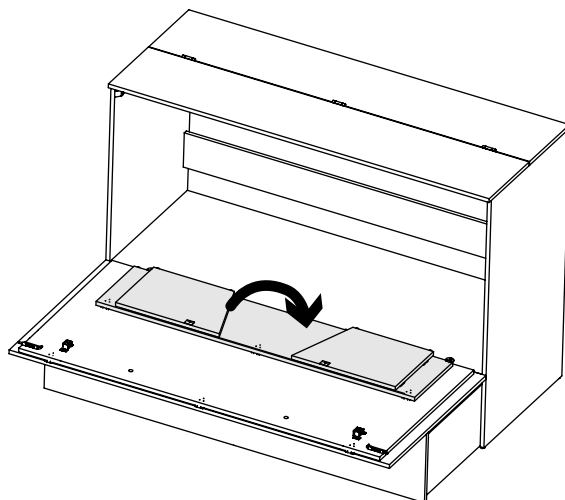

51



ATTENTION

Les barres devraient bien s'enclencher lors de la fermeture de la porte. Si la porte ne se verrouille pas comme il se doit, veuillez communiquer avec le service à la clientèle.

WARNING

The latches should engage securely when the door is closed. If the door does not lock properly, please contact customer service.

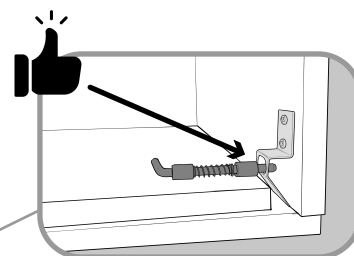
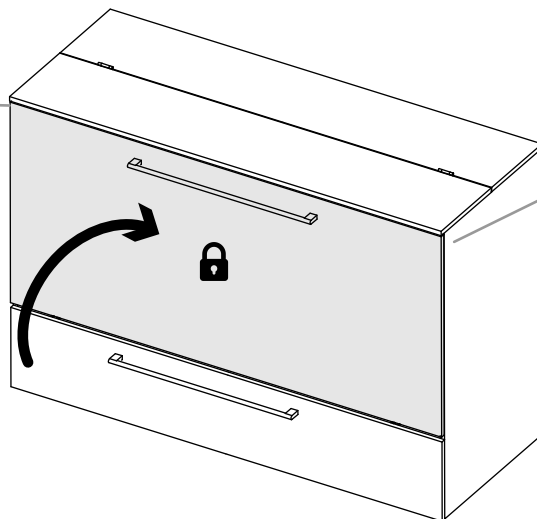
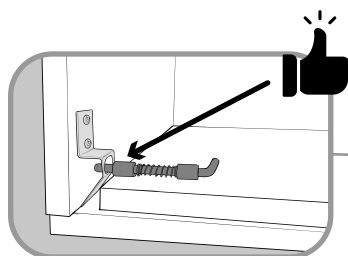

OUVERTURE / OPENING (1/2)

1

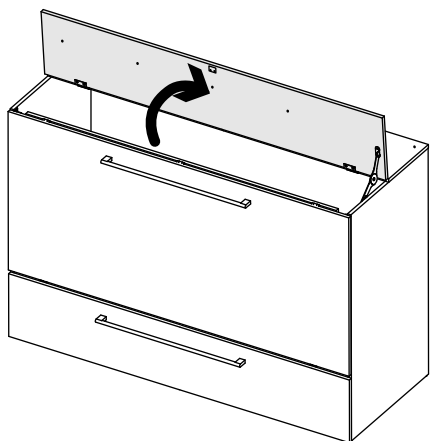

2

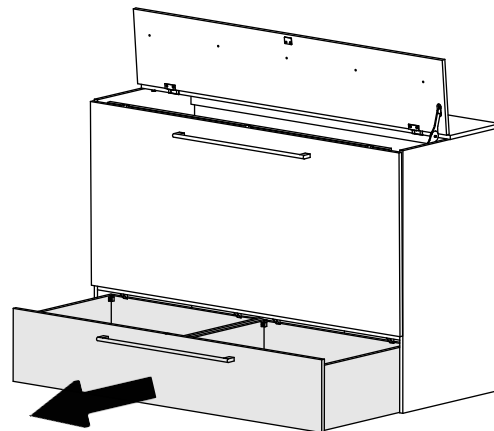

ATTENTION:

Toujours ouvrir les tiroirs avant d'ouvrir la porte.

L'ouverture de la porte sans que les tiroirs ait été ouverts risque de faire basculer le meuble pouvant ainsi causé des blessures graves ou même la mort et des dommages au meuble.

WARNING:

Always open the drawers before opening the door.

Opening the door without the drawers having been opened may cause the cabinet to tip over which can cause serious injury or even death and damage to the furniture.

3

1.

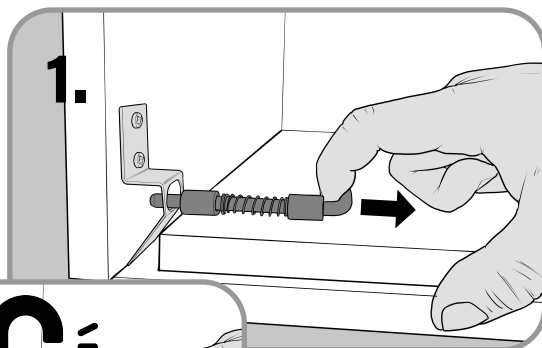

2.

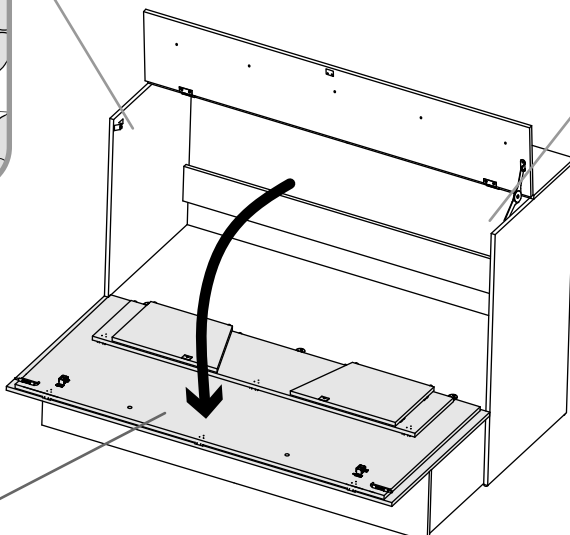
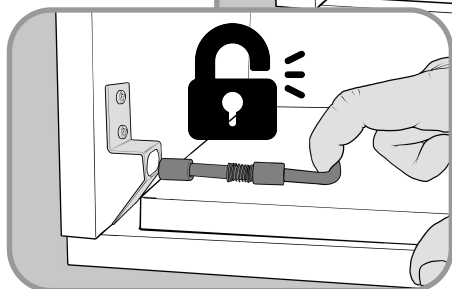
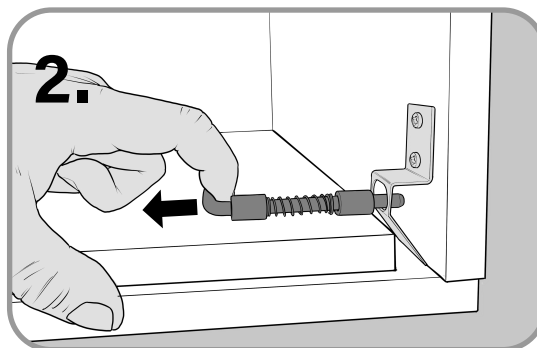

ATTENTION

L'ouverture et la fermeture nécessite un adulte. Un enfant qui fermerait ou ouvrirait le lit risque de l'endommager, de se blesser gravement ou même mourir.

WARNING

Opening and closing requires an adult. A child who closes or opens the bed risks damaging it, injuring himself or even die.

ATTENTION LOURD
WARNING HEAVY



OUVERTURE / OPENING (2/2)

4

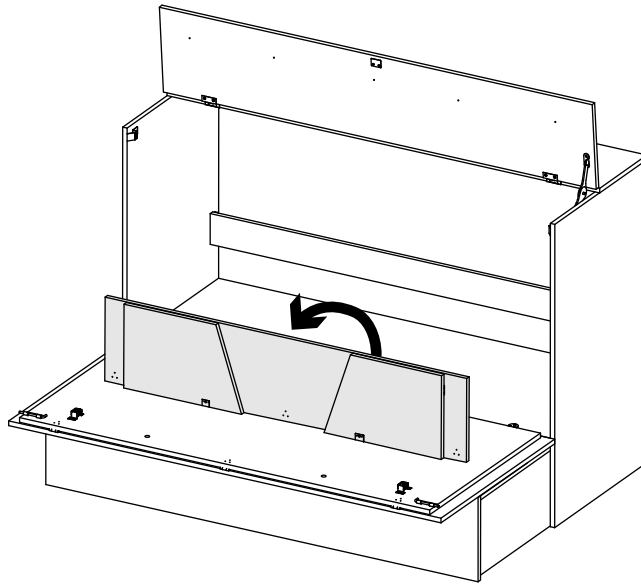

5

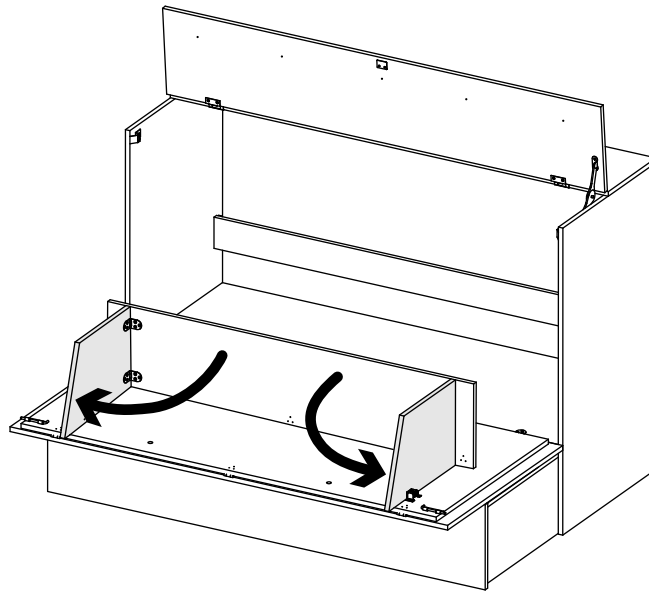

6

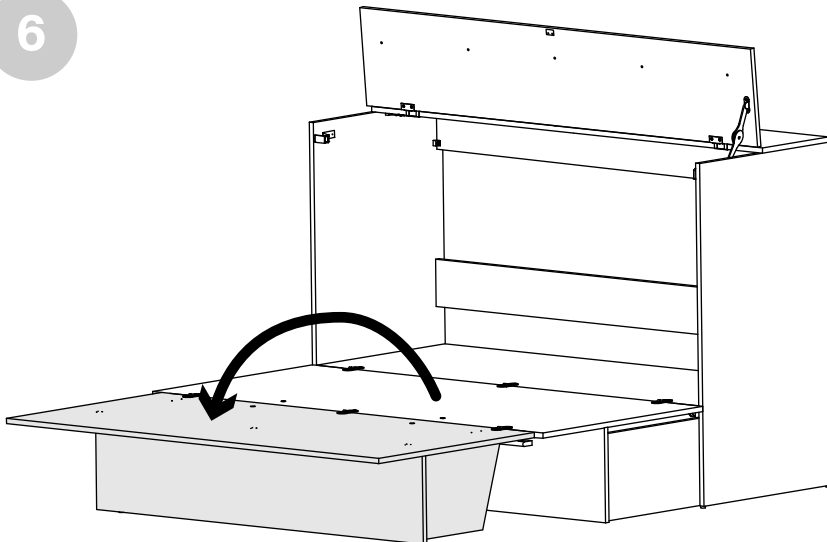

ATTENTION

L'ouverture et la fermeture nécessite un adulte. Un enfant qui fermerait ou ouvrirait le lit risque de l'endommager, de se blesser gravement ou même mourir.

WARNING

Opening and closing requires an adult. A child who closes or opens the bed risks damaging it, injuring himself or even die.

1

ASSEMBLAGE TRAVERSE / CROSSPIECE ASSEMBLY (1/2)

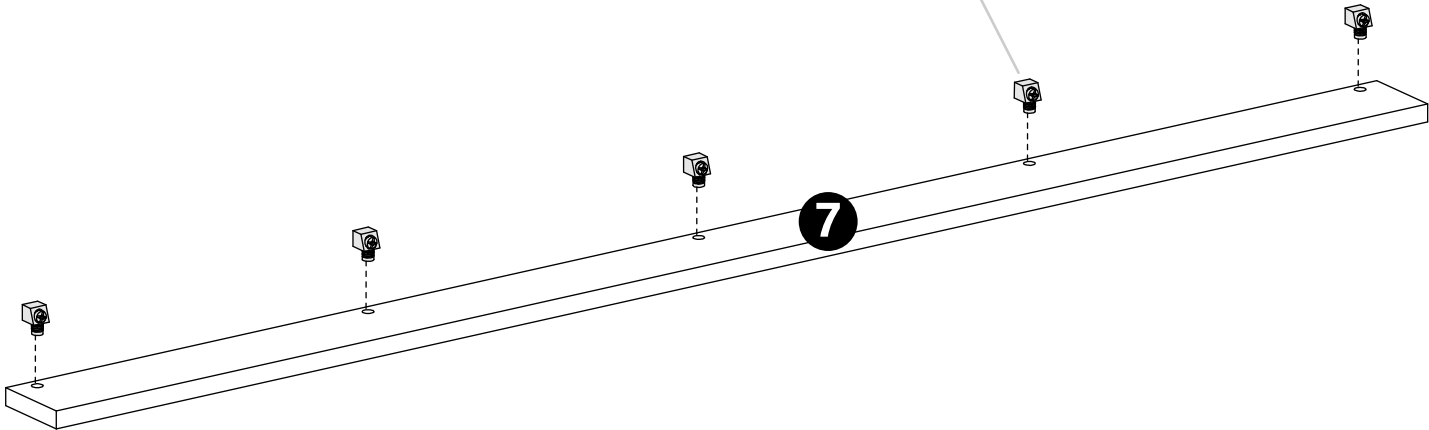
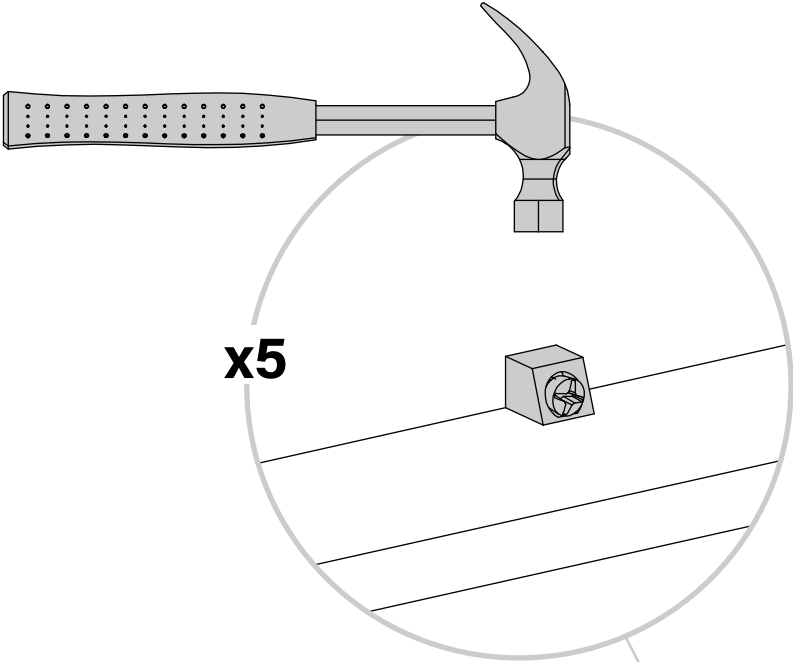

2

ASSEMBLAGE TRAVERSE / CROSSPIECE ASSEMBLY (2/2)

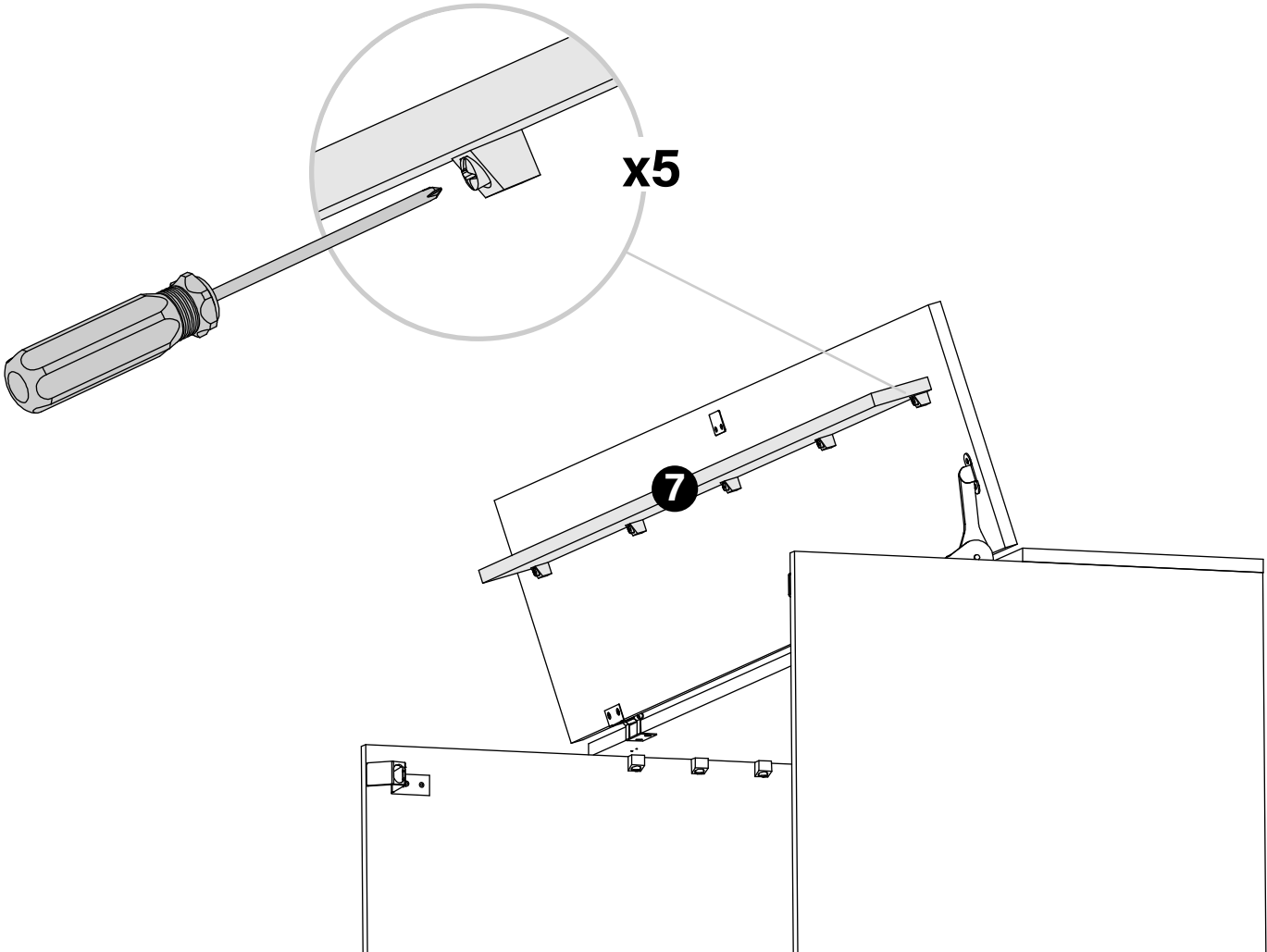
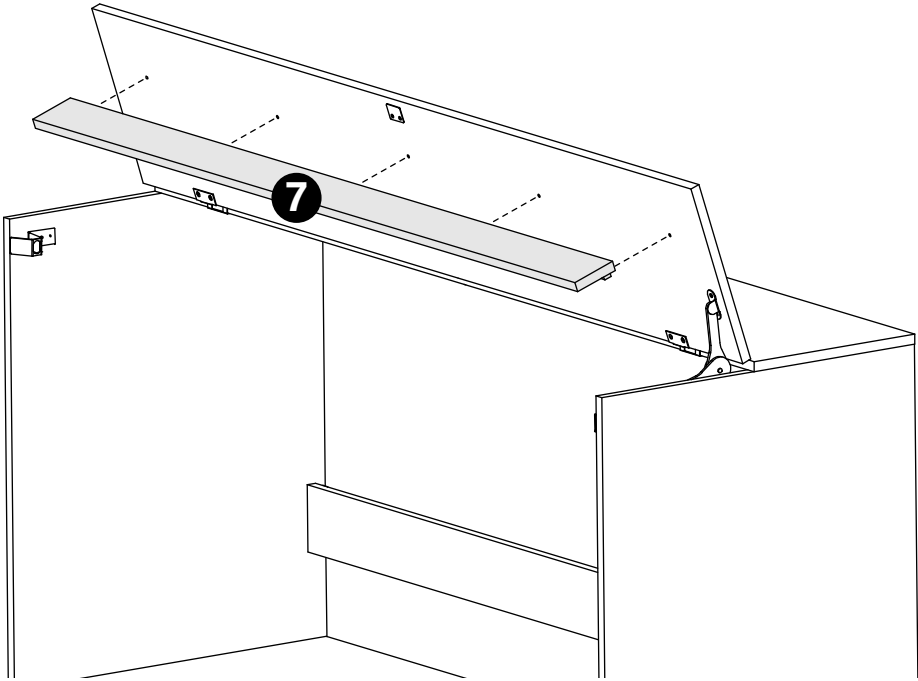

INSTALLATION SUR LE MUR / INSTALLATION AT THE WALL

1

Retirer la moulure du mur où sera installé le lit.

Remove the moulding from the wall where the bed will be installed.

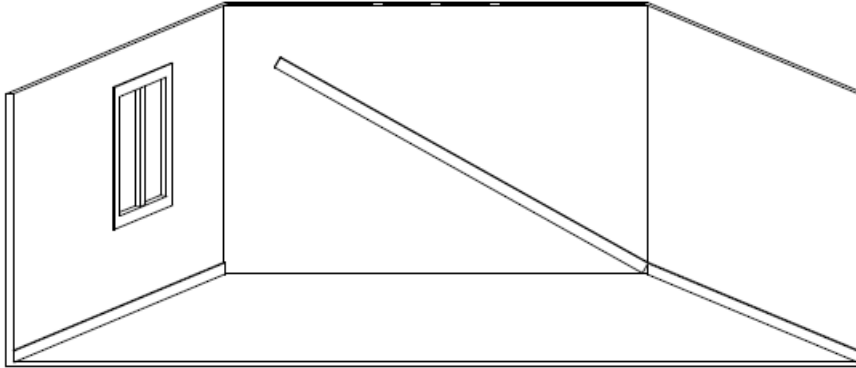

2

Positionner le lit à l'endroit désiré. / Place the bed at the desired location.

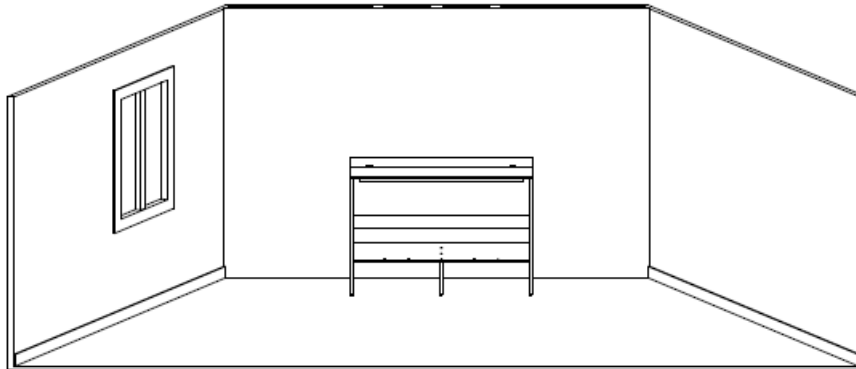

3

Placer le niveau sur le cabinet et corriger la verticale et l'horizontale au besoin. S'assurer que le cabinet est au niveau dans les deux sens, sinon la fermeture du lit sera compromise.

Place the level on the cabinet and correct the vertical and horizontal as needed. Ensure that the cabinet is level in both directions otherwise the closure of the bed will be compromised.

