

ASSEMBLY INSTRUCTION

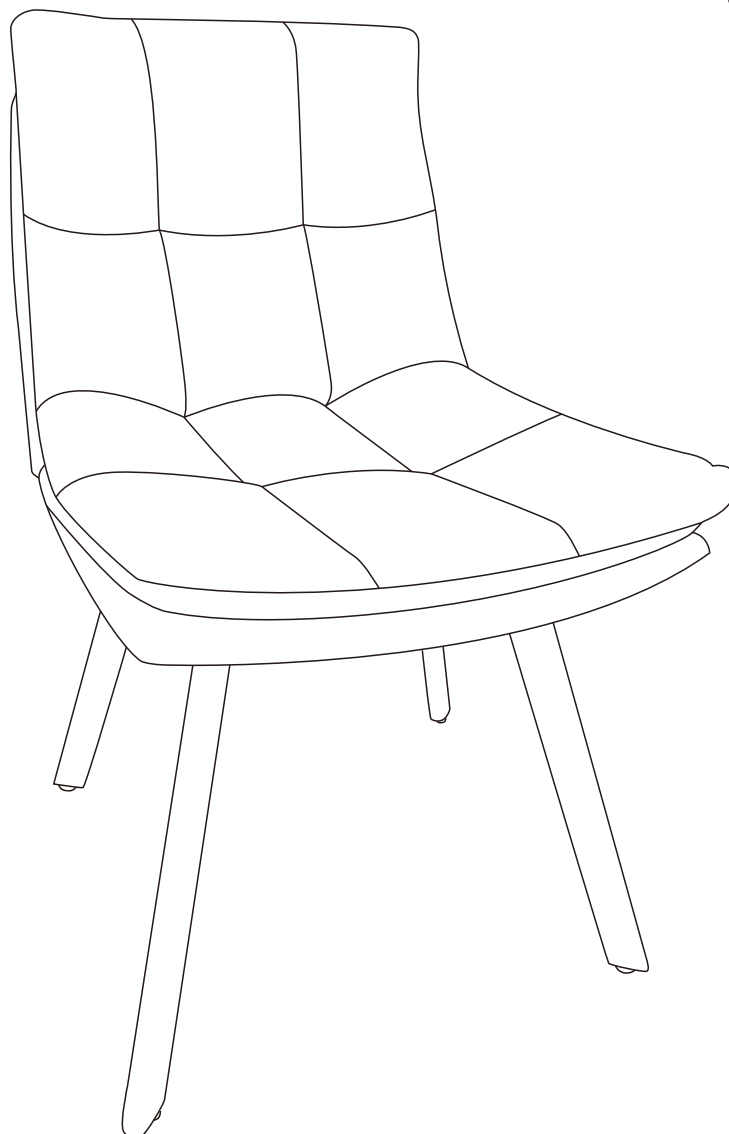

**THIS INSTRUCTION CONTAINS IMPORTANT SAFETY INFORMATION.
PLEASE READ BEFORE ASSEMBLY AND KEEP FOR FUTURE REFERENCE.**

Parts List

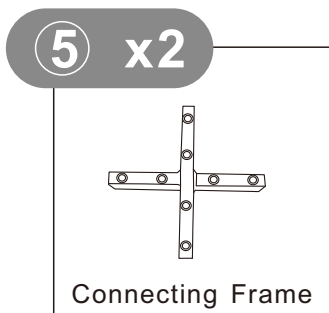
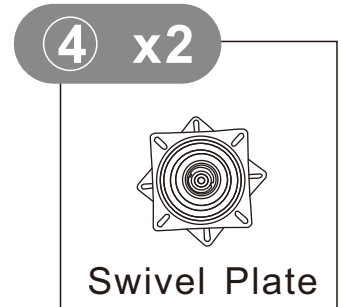
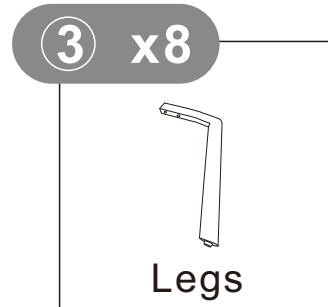
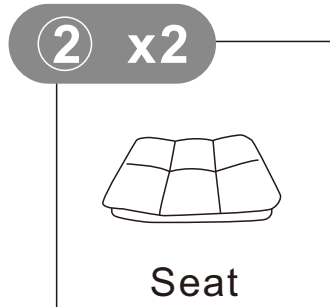
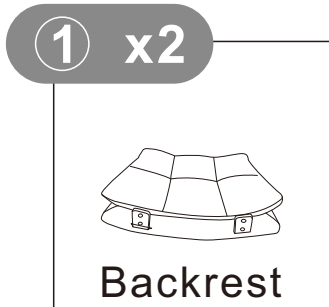

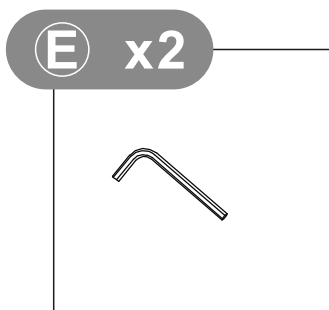
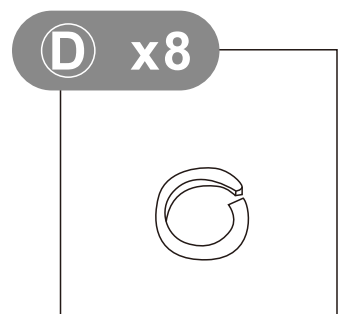
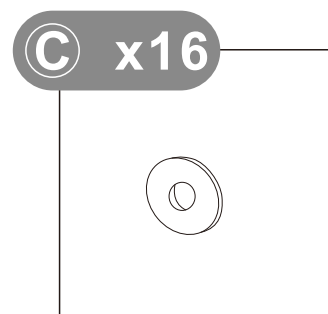
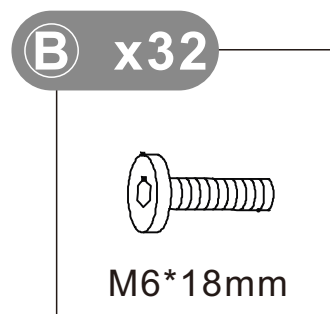
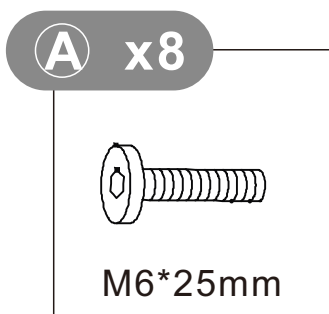

Hardware List

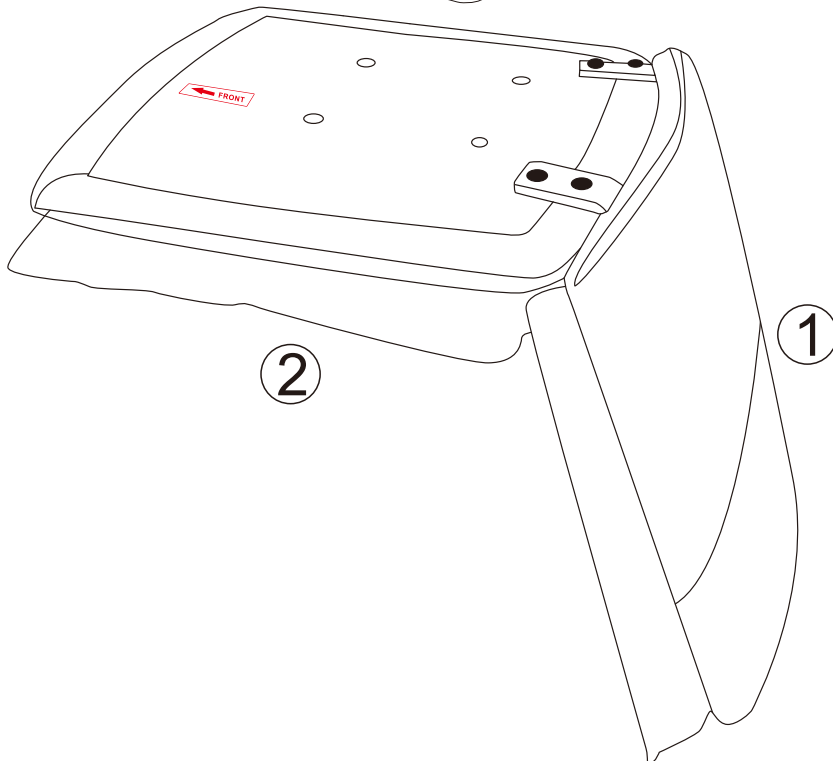
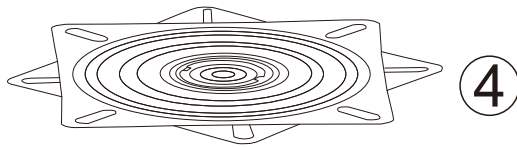
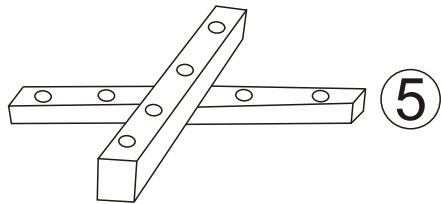
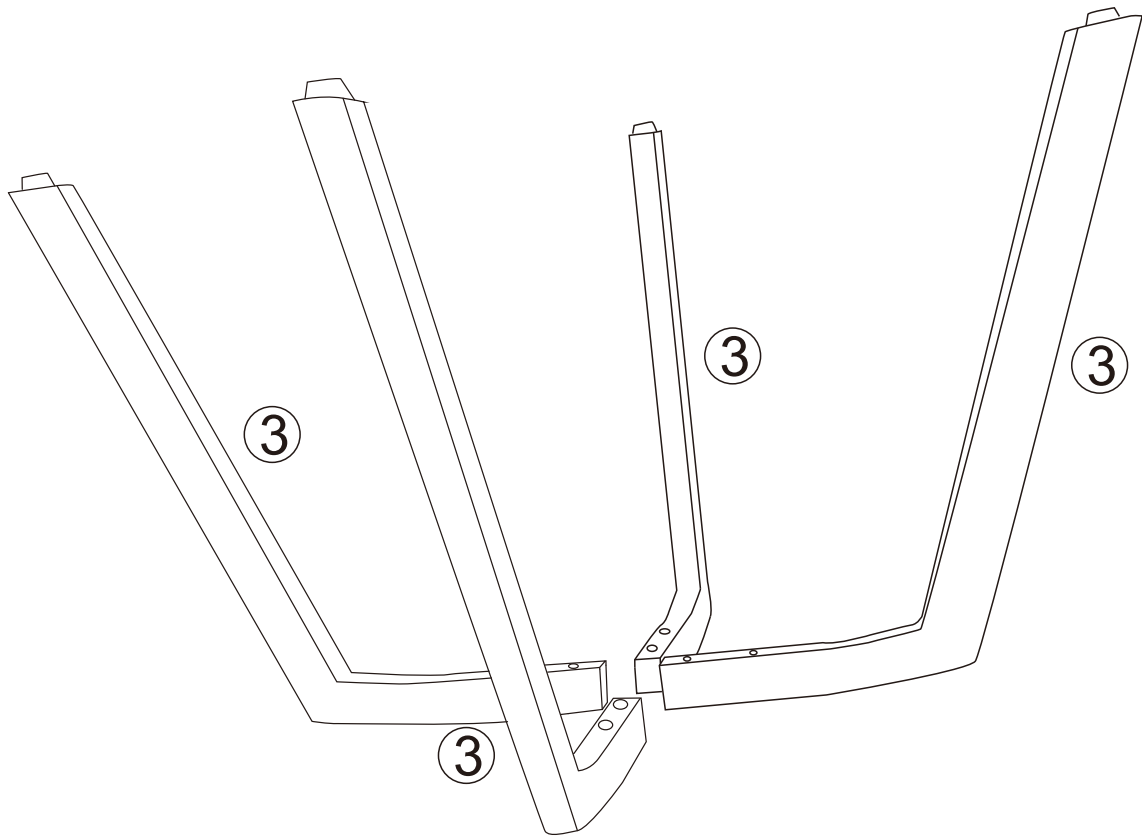



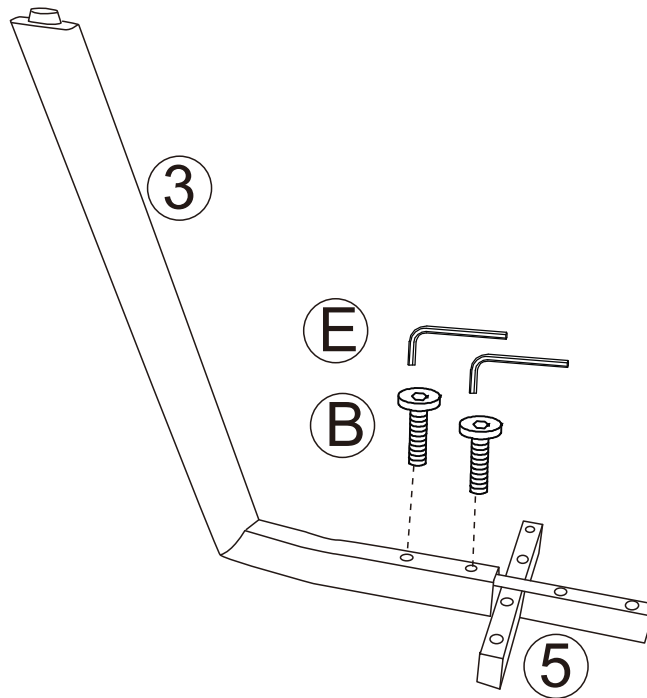

STEP1: Please tighten the screws to 80%.

E		x1
B		x2
 80%		



STEP2: Please tighten the screws to 80%.

E		x1
B		x6
 80%		

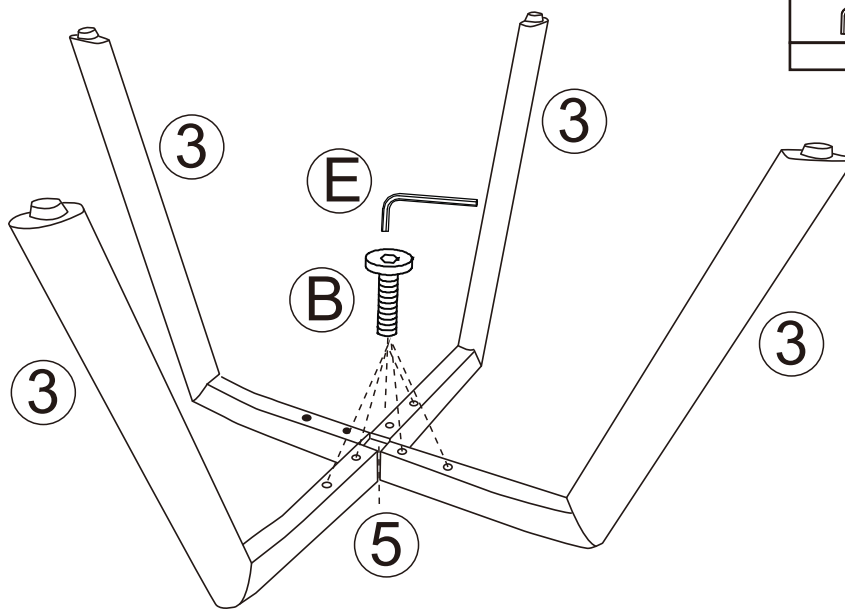

STEP3:

Please insert the 4 screws from step 3 into the holes and tighten them to 80%. Then, tighten all the screws from steps 1, 2, and 3 to 100%.

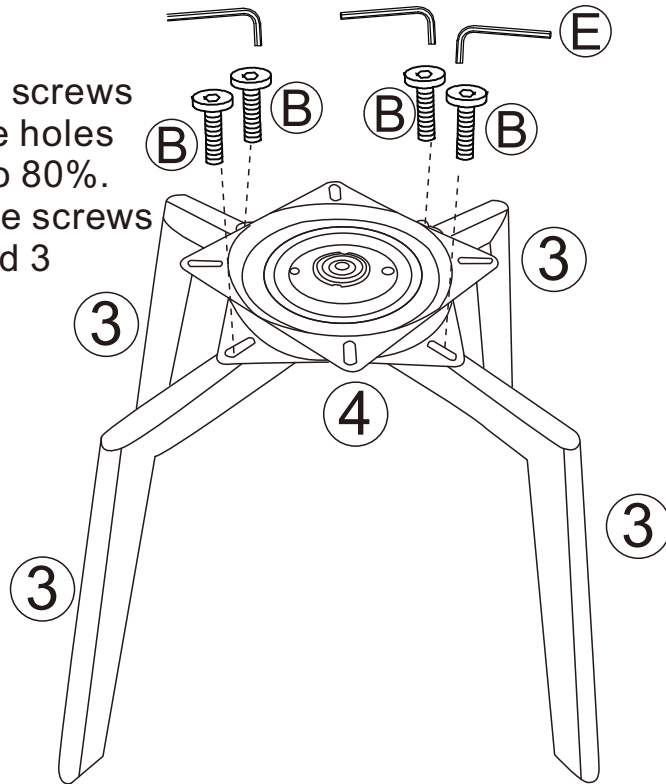

E		x1
B		x4
		100%

STEP4: Please tighten the screws to 80%.

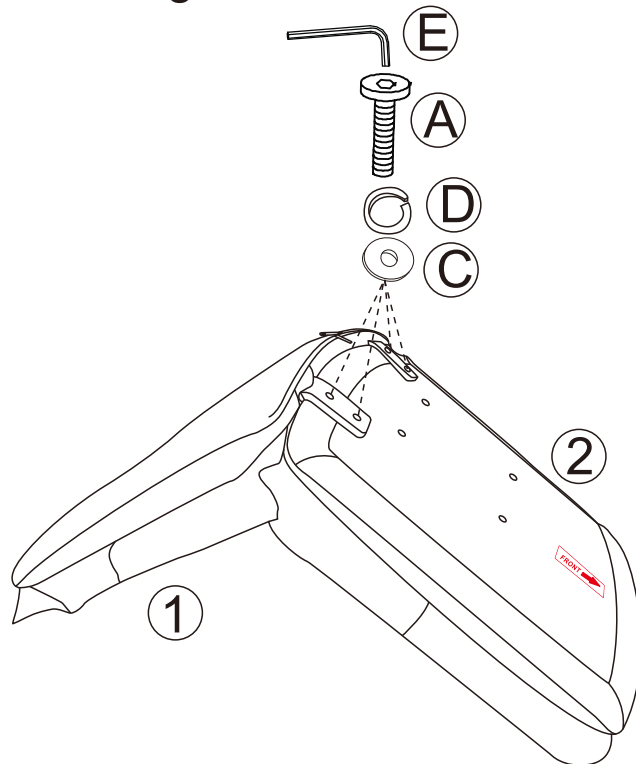

E		x1
A		x4
C		x4
D		x4
		80%

STEP5:Please lay the chair flat and put the hardware C upon the 4 holes

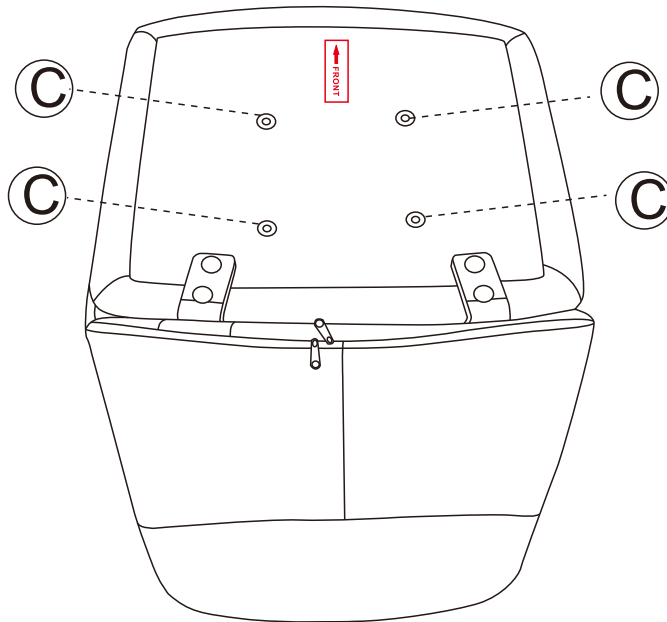
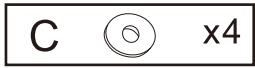

STEP6: Please tighten all screw B to 80% in step 6. Then tighten all screws from step 4 and step 6 to 100%.

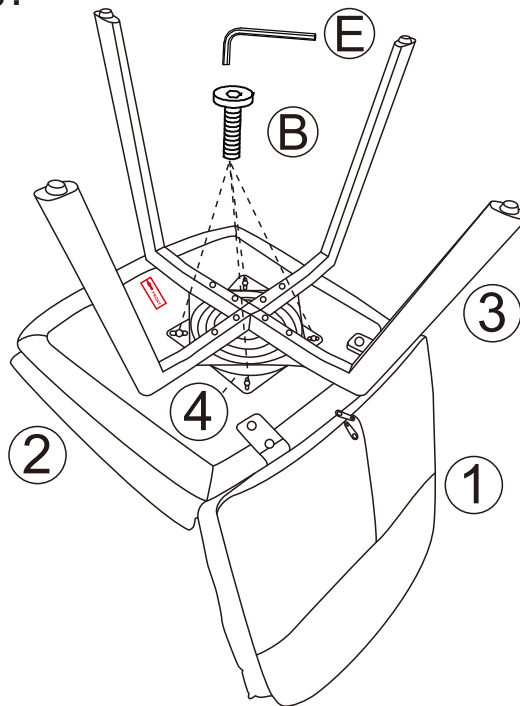
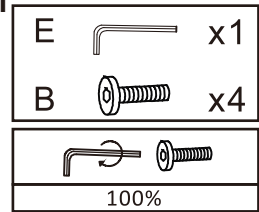

STEP 7:

Adjust the leveling feet for balance.

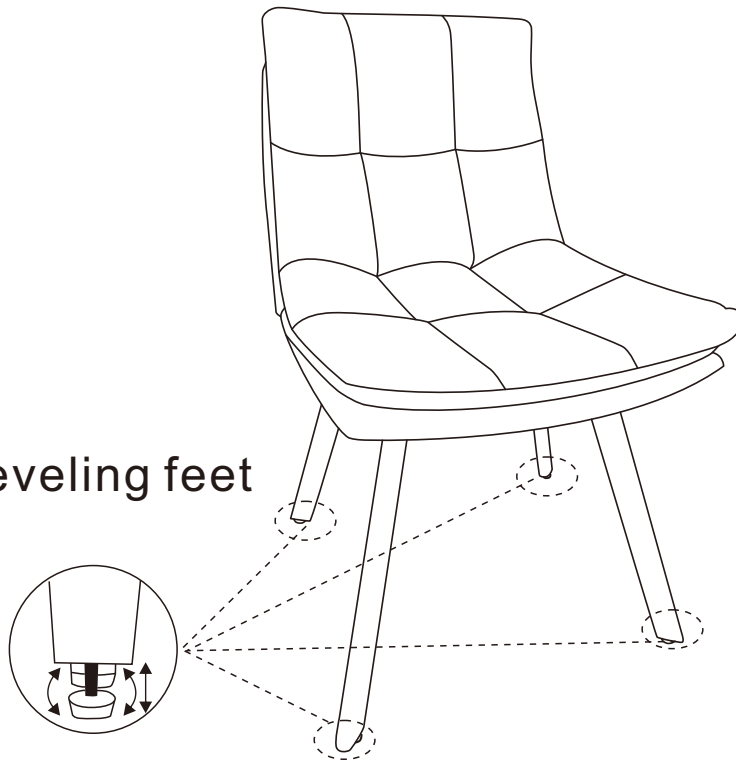

FINISH:

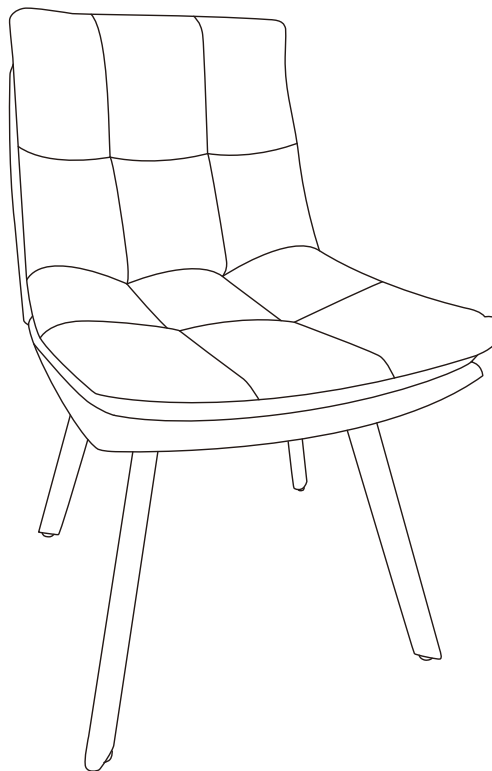

FQA & Warning

Q1: What should I do if I receive a wrong or damaged product?

A1: Please reach out to our Customer Service Team

Q2: What should I do if I want to return the product?

A2: Please keep the original package and email with order ID and return reason and we will help you return it.

Q3: What should I do if I don't receive the package when the logistics track shows it has been delivered?

A3: Please email with order ID and we will send a new one to you after we confirm with the carrier.

Q4: What should I do if the logistics track has not been updated for more than 3 days?

A4: Please email with order ID and tracking number and we will urge the carrier to deliver the product to you as soon as possible.

Q5: What should I do if I have assembly problems?

A5: Please email with order ID and detailed description and we will provide you the professional technical support.

Q6: What should I do if there is some parts or screws missing?

A6: Please email with order ID and the number or letter of the missing part or screws, we will send it to you.

Warning:

1. There are small screws in the package, please keep them out of reach of children to prevent any accident.
2. Children are forbidden to climb or play on the product to avoid any injury.
3. Keep plastic packing bags out of reach of children to avoid any potential danger.
4. This product is intended for indoor use only.
5. Keep the product away from fire sources and high temperatures. Do not expose the product to direct sunlight.