

# ASSEMBLY INSTRUCTIONS

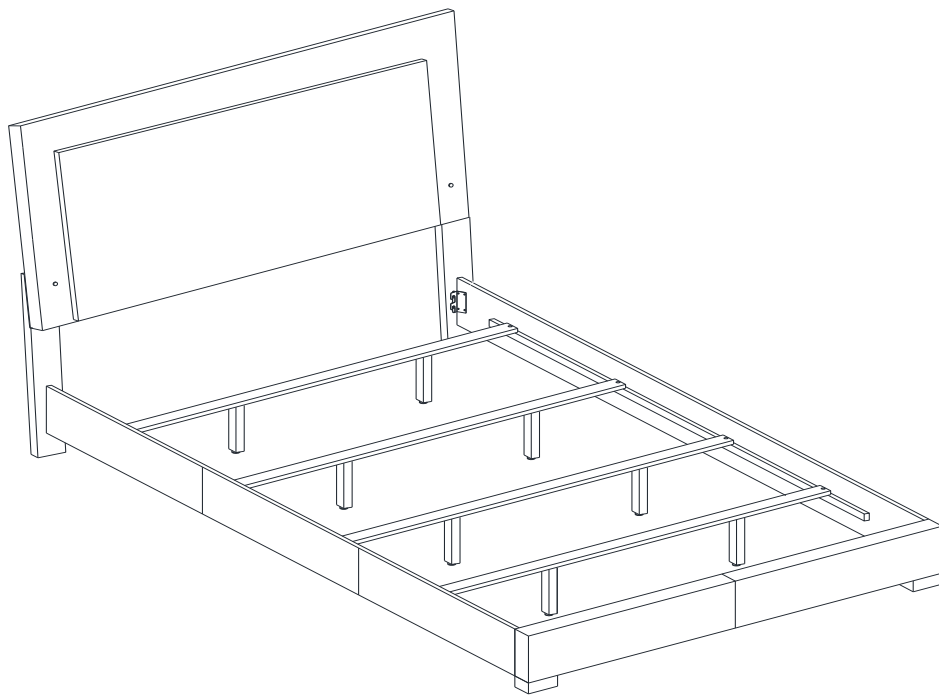

*Fine Furniture for every stage of life*

## **(B1&B2)** ***California King Bed***

REVISION 0 : 07/09/2015  
REVISION 1 : 07/25/2019

# ASSEMBLY INSTRUCTIONS

## ASSEMBLY TIPS:

1. Remove hardware from box and sort by size.
2. Please check to see that all hardware and parts are present prior to start of assembly.
3. Please follow attached instructions in the same sequence as numbered to assure fast & easy assembly.



## WARNING!

1. Don't attempt to repair or modify parts that are broken or defective. Please contact the store immediately.
2. This product is for home use only and not intended for commercial establishments.





ASSEMBLY TIME

20 MINUTES





## PARTS IDENTIFICATION

### B1 ( BOX 1 )

A	HEADBOARD PANEL		1PC
B	RIGHT HEADBOARD LEG		1PC

C	LEFT HEADBOARD LEG		1PC
---	--------------------	---	-----

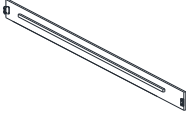
### B2 ( BOX 2 )

D	BED SLAT		4PCS
E	BED SLAT SUPPORT WITH LEVELER		8PCS
F	BED RAIL		2PCS
G	FOOTBOARD LEG		2PCS

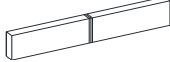
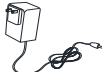
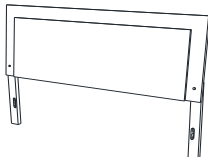
H	FOOTBOARD PANEL		1PC
I	ADAPTER PLUG		1PC
HB	HEADBOARD COMPLETE		1PC

## NOTE:

Phillips head screw driver is required in the assembly process; however, manufacturer does not provide this item.

# ASSEMBLY INSTRUCTIONS

## ASSEMBLY TIPS:

1. Remove hardware from box and sort by size.
2. Please check to see that all hardware and parts are present prior to start of assembly.
3. Please follow attached instructions in the same sequence as numbered to assure fast & easy assembly.





## WARNING!



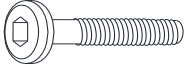

1. Don't attempt to repair or modify parts that are broken or defective. Please contact the store immediately.
2. This product is for home use only and not intended for commercial establishments.

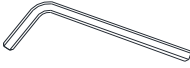
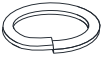
## HARDWARE IDENTIFICATION

### Z-B1 (BOX 1) - HARDWARE PACK IS LOCATED IN (B1)

1	<b>BOLT</b> (M6 x 30mm - BLK)		6PCS	3	<b>FLAT WASHER</b> (1/4" X 13mm - BLK)		6PCS
2	<b>SMALL ALLEN WRENCH</b> (M4 x 60mm - BLK)		1PC	4	<b>LOCK WASHER</b> (1/4" - BLK)		6PCS

### Z-B2 (BOX 2) - HARDWARE PACK IS LOCATED IN (B2)

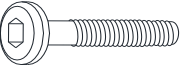
5	<b>SHORT FLAT HEAD SCREW</b> (M4 x 32mm - RBW)		8PCS	8	<b>SMALL ALLEN WRENCH</b> (M4 x 60MM - BLK)		1PC
6	<b>LONG FLAT HEAD SCREW</b> (M4 x 50mm - RBW)		6PCS	9	<b>BIG ALLEN WRENCH</b> (M5 x 65MM - BLK)		1PC
7	<b>BOLT</b> (M6 x 40mm - BLK)		8PCS				

## NOTE:

Phillips head screw driver is required in the assembly process; however, manufacturer does not provide this item.

# ASSEMBLY INSTRUCTIONS

## STEP 1

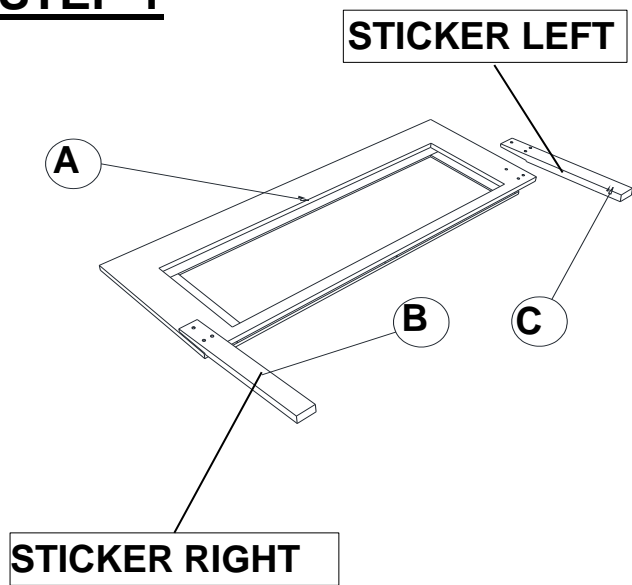

## STEP 2

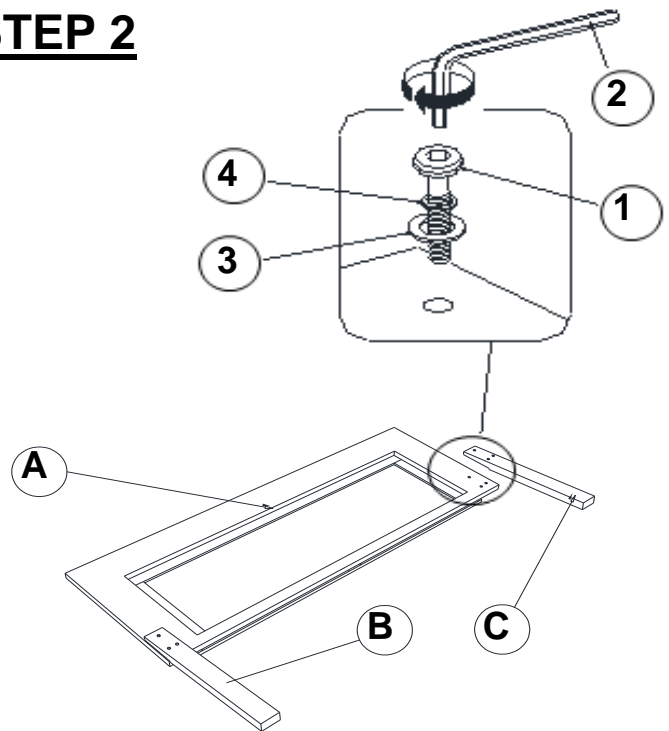

IF PURCHASE HEADBOARD ONLY, SKIP BELOW STEPS

## STEP 3

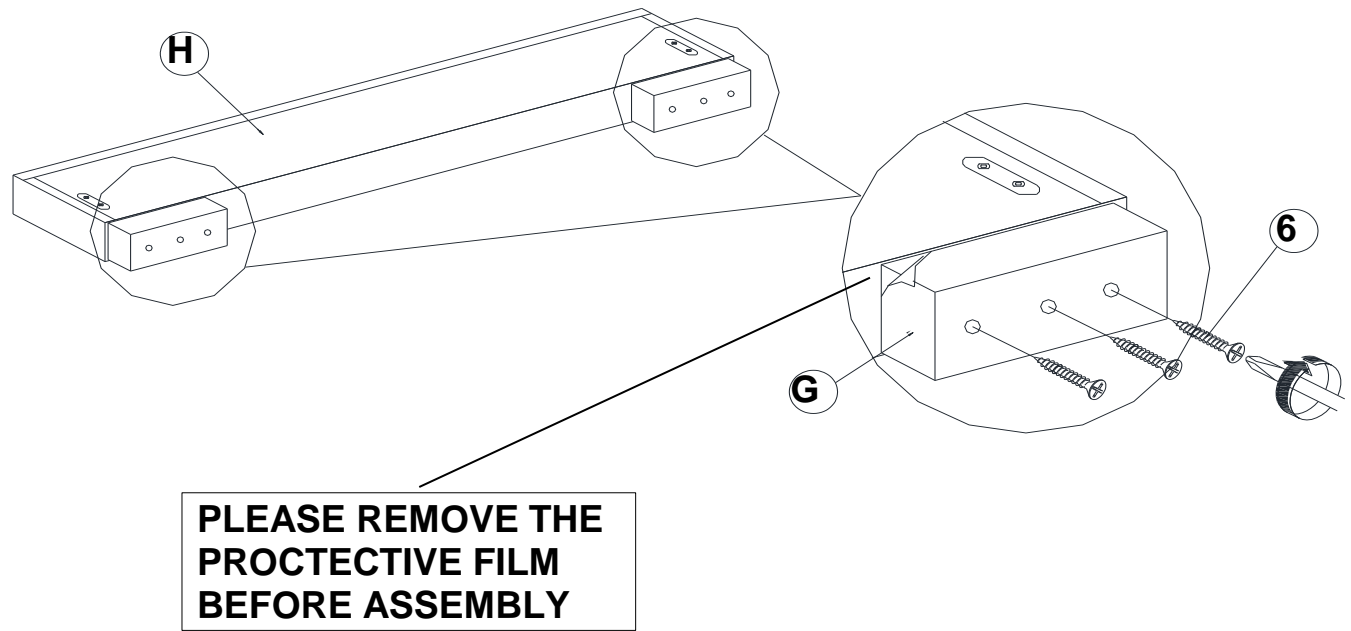

# ASSEMBLY INSTRUCTIONS

## STEP 4

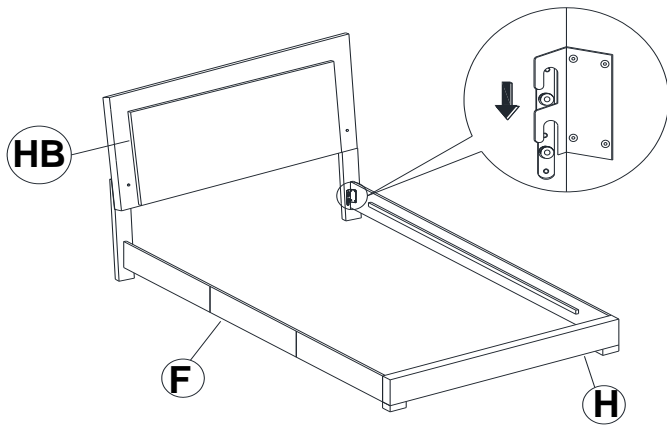

## STEP 5

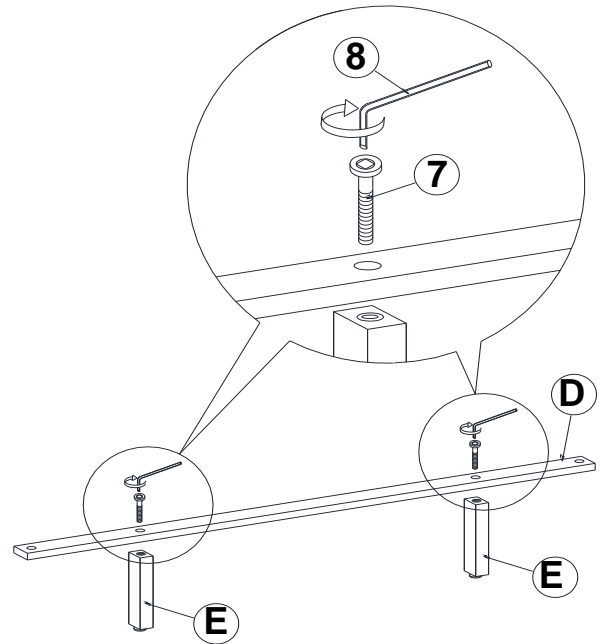

## STEP 6

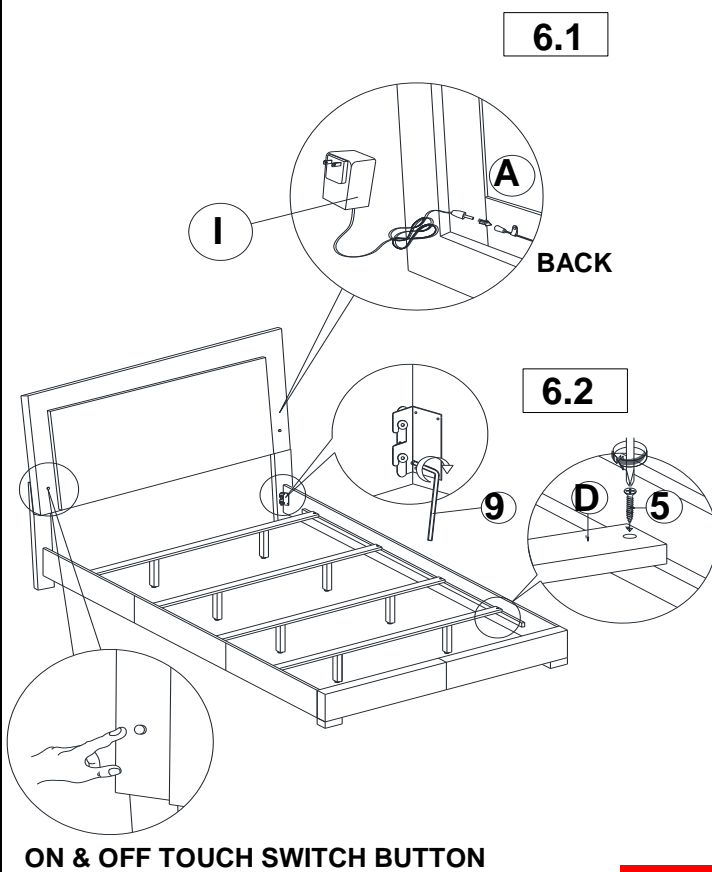

## STEP 7 COMPLETE

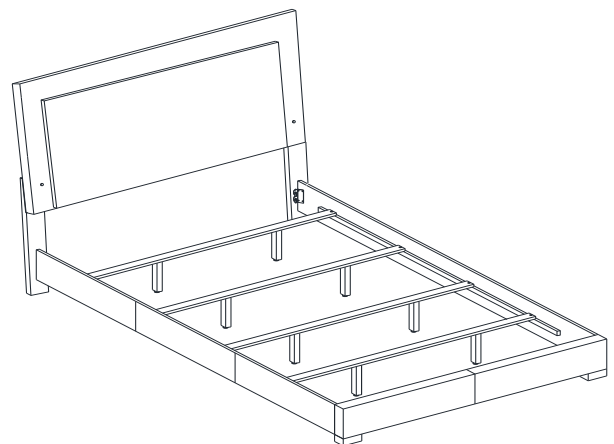

Inner Size : 72.75"W X 85.25"D

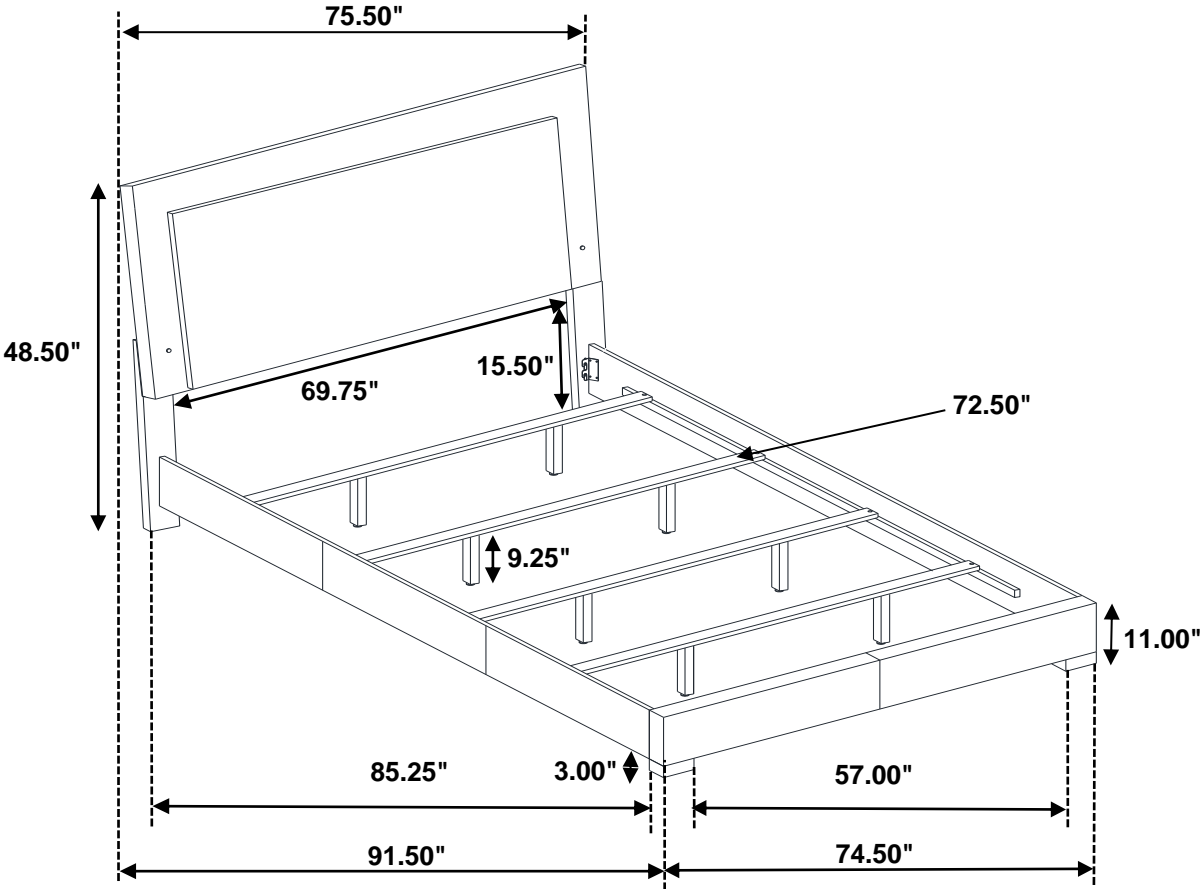

Note : Dimension tolerance  $\pm 5\%$