

Owner Manual

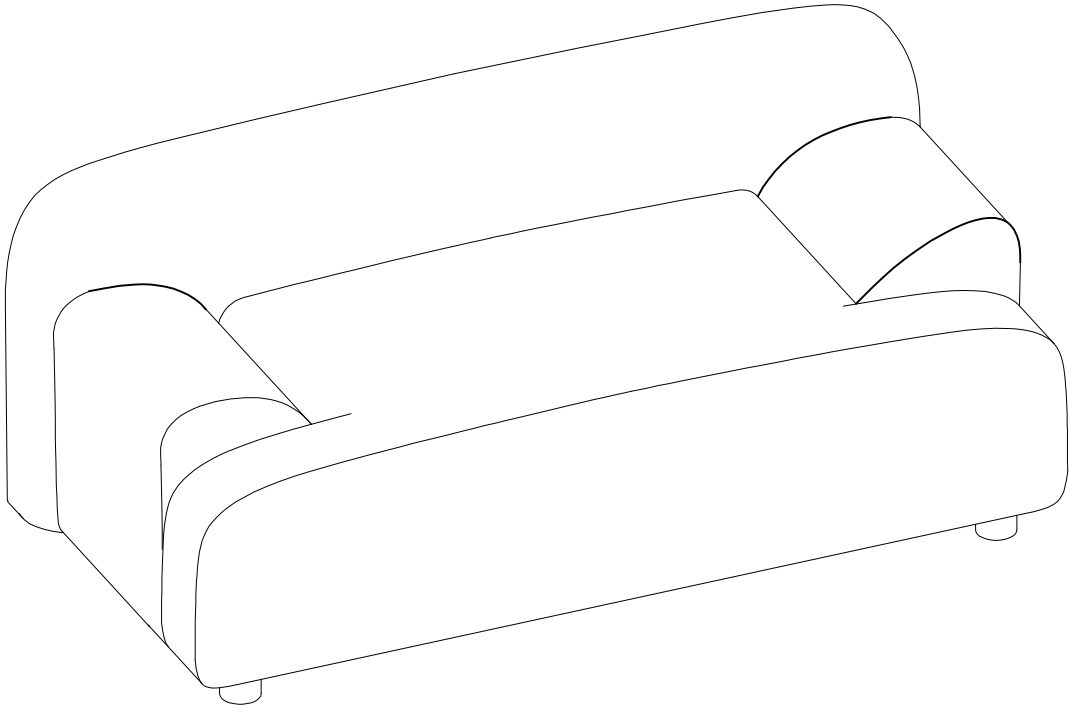

NOTE: This brochure contains **IMPORTANT** safety info.
Please read and keep for future reference.

MAINTENANCE AND WARNING

- 1.Keep furniture away from heat sources.
- 2.Do not clean furniture with harsh cleaner or polishes.Do not use detergents,solvents, abrasives,spray packs or leather cleaner.Use non-color mild soa with warm water to clean spills(Mix 1:10 soap to water).
- 3.Do not place furniture under direct sunlight,material will possibly fade over time.

4. Do not use on site dry cleaning machine. Children should not climb or jump on the furniture.

5. Do not write on furniture that is not protected by a padded barrier.

6. Not for commercial use, only for residential use.





Weight Limitation

900 LBS

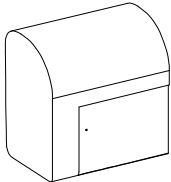
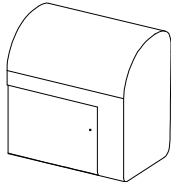
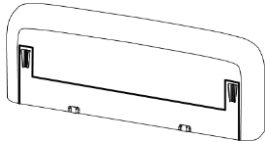
PARTS LIST

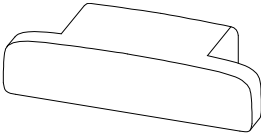
A	x1	B	x1	C	x1
					
Left Arm		Right Arm		Back Frame	

D	x1
	
Seat Frame	

E	x4
	
Legs	

Tools needed

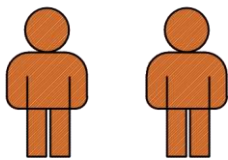
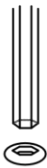

Two person

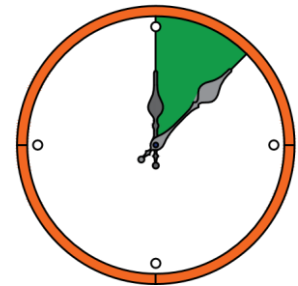



Around 20 min

03/11

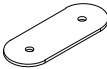
PARTS LIST

#1	x2
	
Bolt	
M8*65mm	
#5	x2
	
Bracket	

#2	x6
	
Flat washer	

#3	x6
	
Spring gasket	

#4	x4
	
Bolt	
M8*30mm	

Angle iron

TOOL LIST

#6	x1
	
Allen Key	
M8	

HARDWARE SPARE LIST

#1	x1
	
Bolt	
M8*65mm	

#2	x1
	
Flat washer	

#3	x1
	
Spring gasket	

#4	x1
	
Bolt	
M8*30mm	

ASSEMBLY INSTRUCTIONS

STEP-1

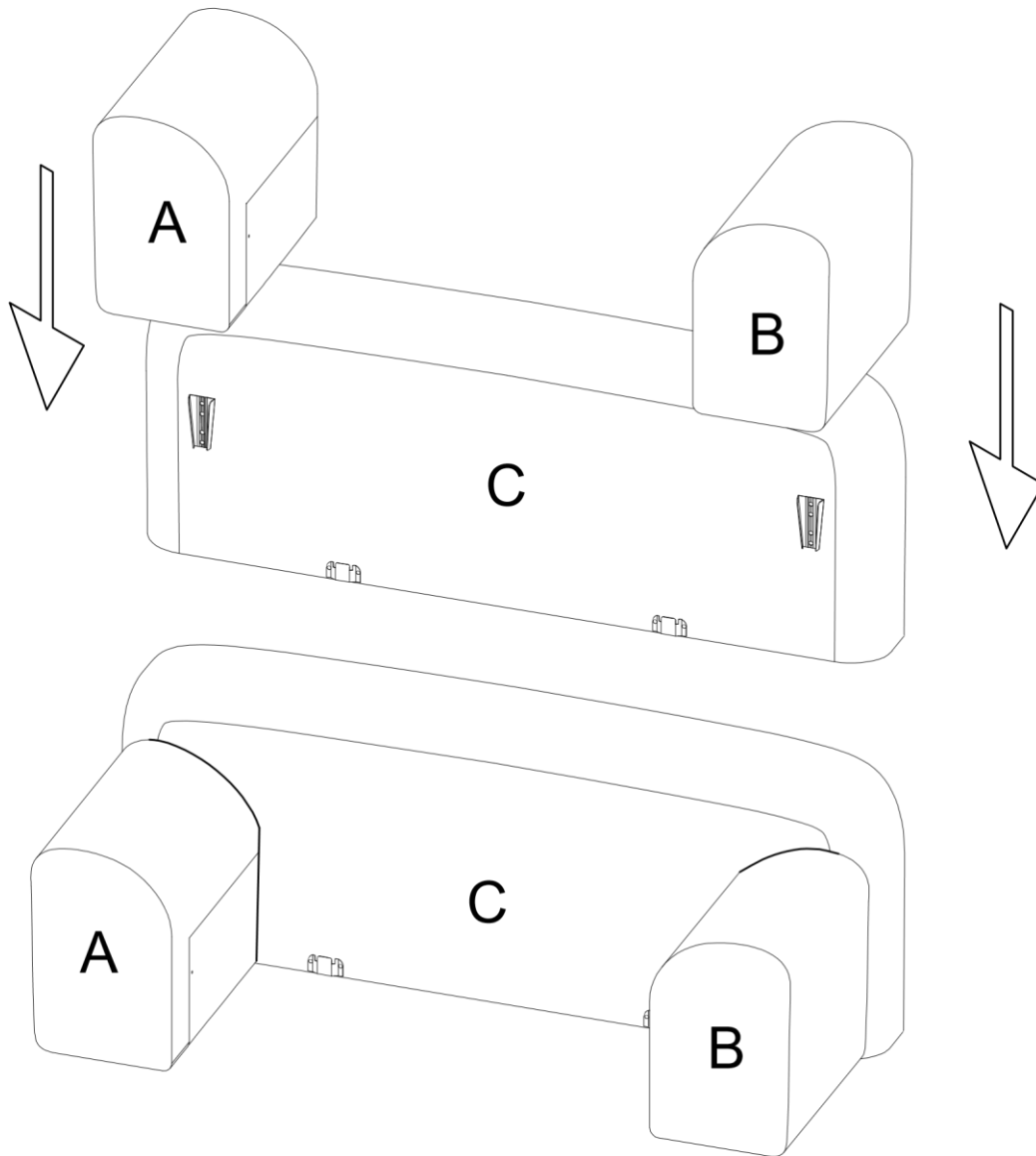

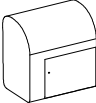
A	x1
	
Left Arm	

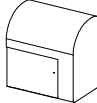
B	x1
	
Right Arm	

C	x1
	
Back Frame	

ASSEMBLY INSTRUCTIONS

STEP-2

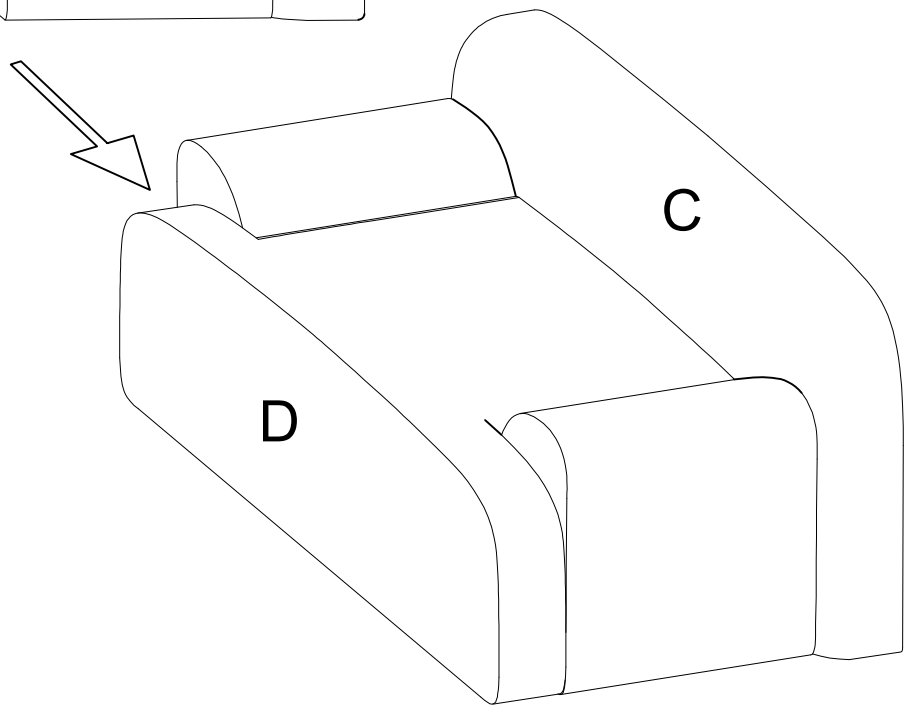
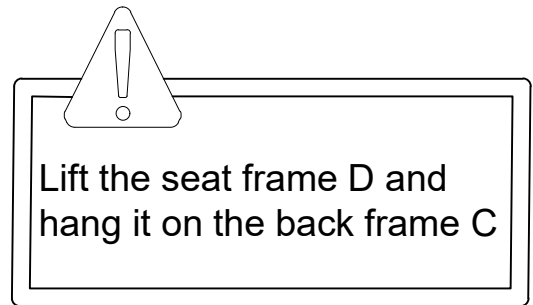
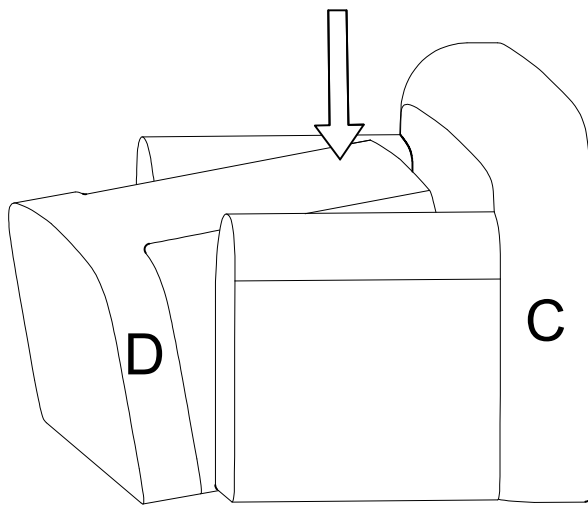

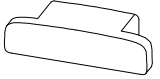
D	x1
	
Seat Frame	

ASSEMBLY INSTRUCTIONS

STEP-3

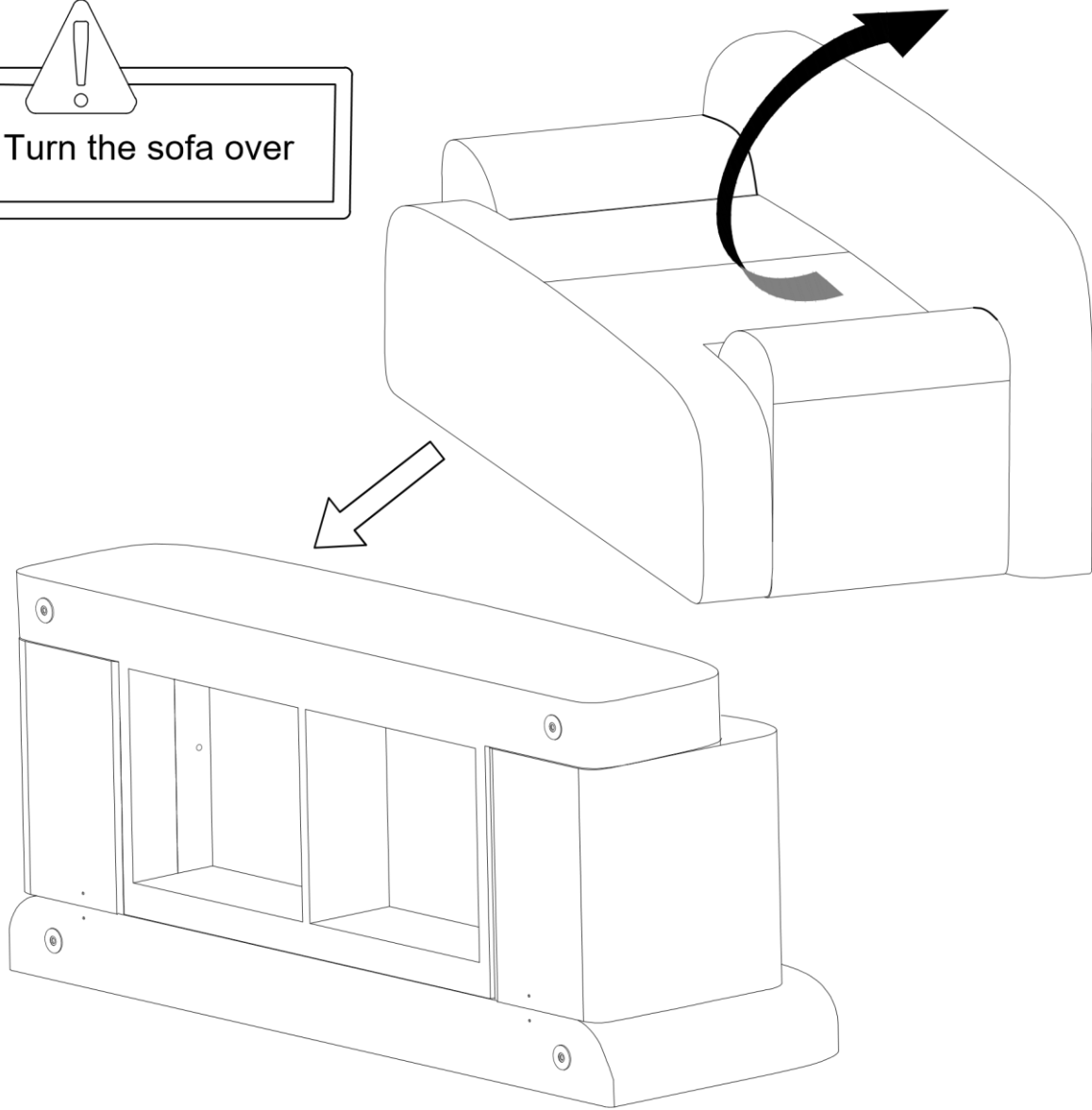
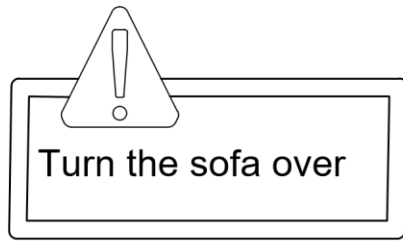

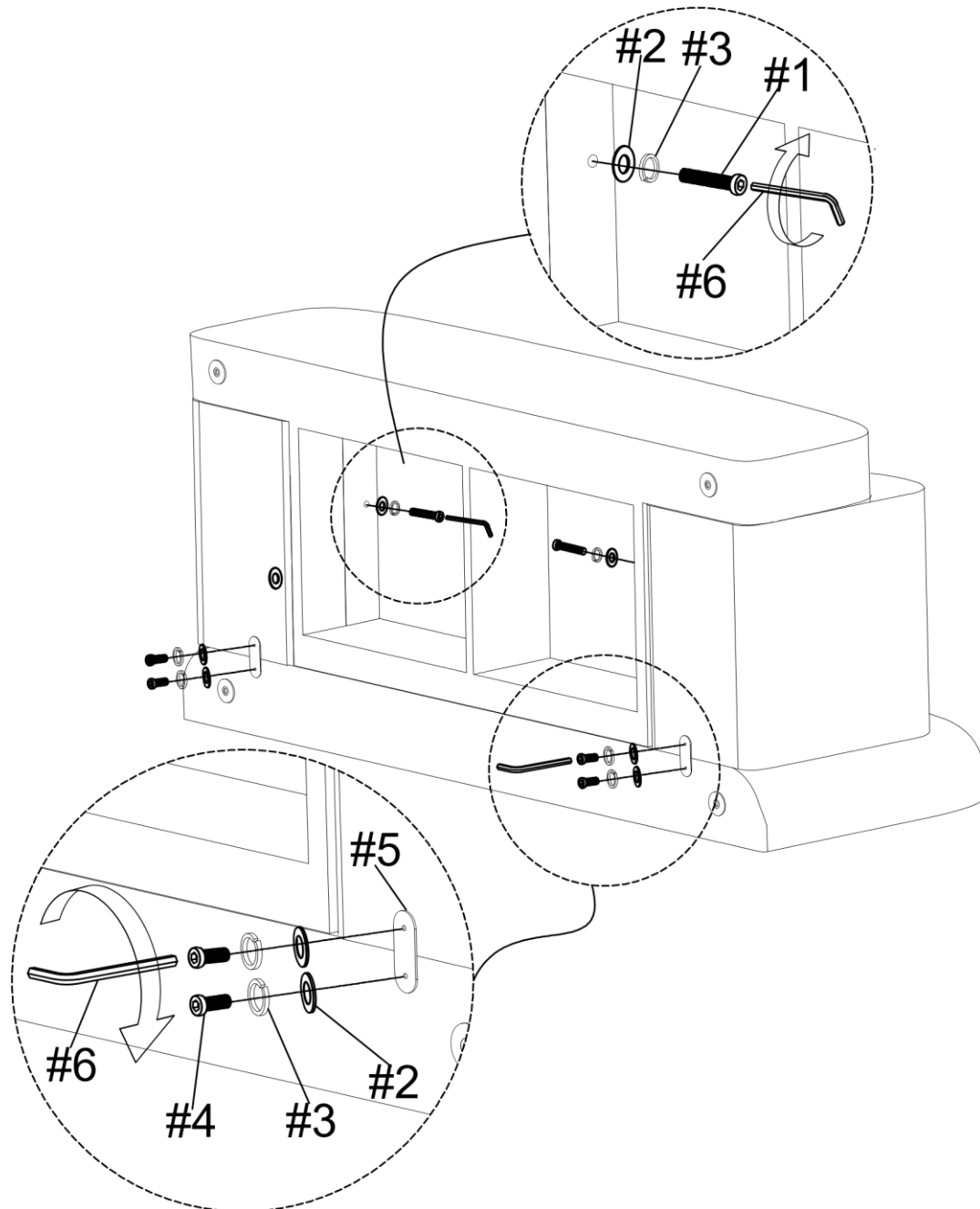

ASSEMBLY INSTRUCTIONS

STEP-4





#1	x2
	
Bolt	
M8*65mm	

#2	x6
	
Flat washer	

#3	x6
	
Spring gasket	

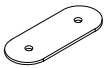
#4	x4
	
Bolt	
M8*30mm	

#5	x2
	
Angle iron	

#6	x1
	
Allen Key	
M8	

ASSEMBLY INSTRUCTIONS

STEP-5

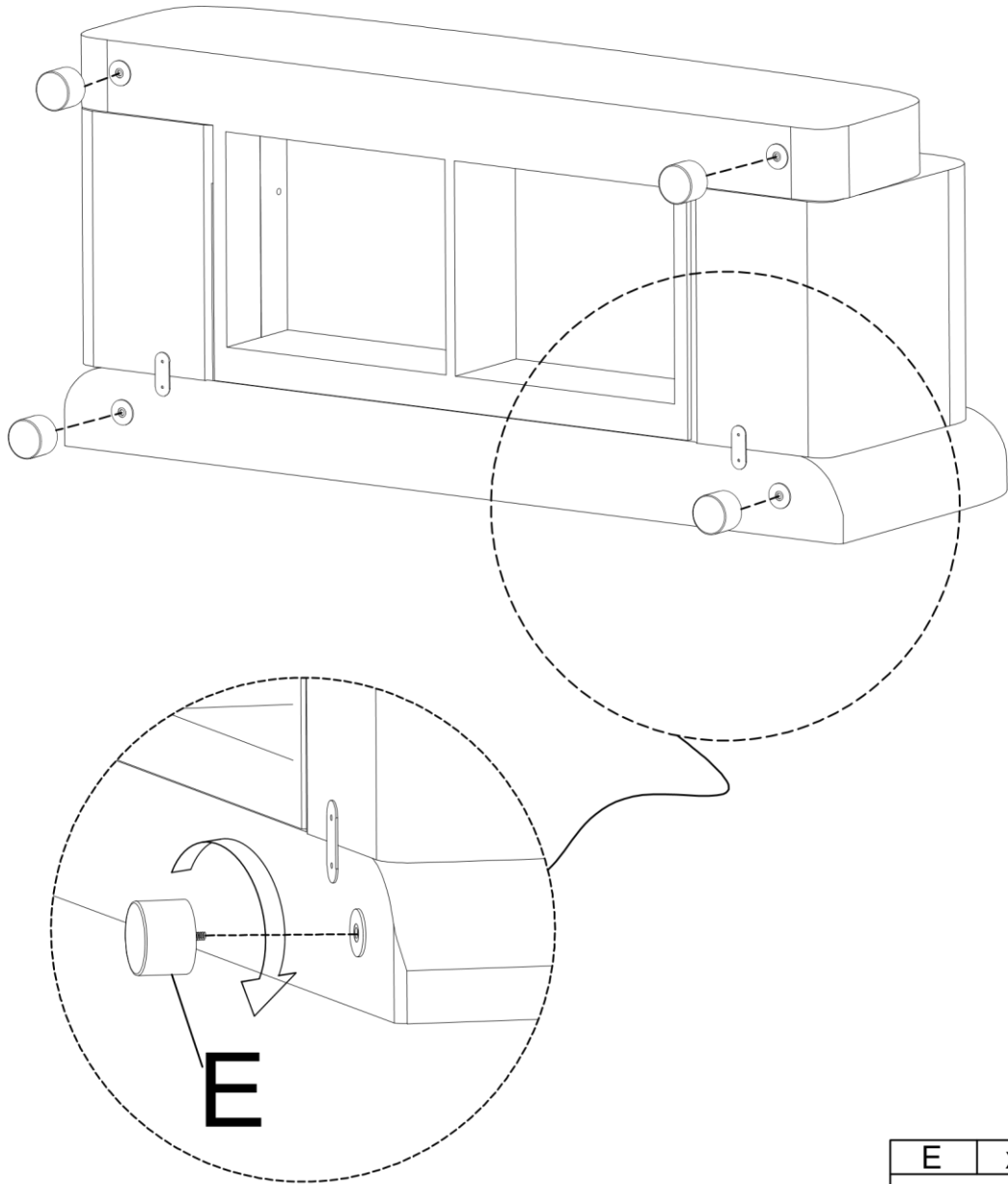

E	x4
	
Legs	

ASSEMBLY INSTRUCTIONS

STEP-6



After assembly is completed, the fabric needs to be arranged in the direction shown in the following picture.

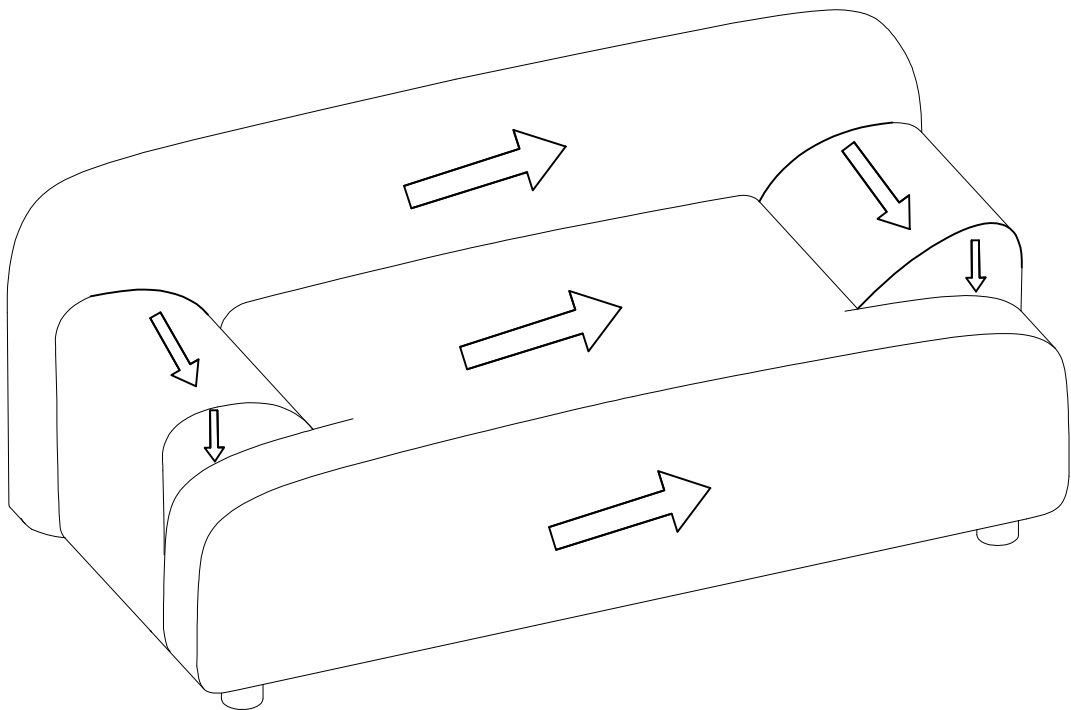

WARRANTY

1. We strive to offer high-quality products, and we also try our best to satisfy each and every customer that orders from us with product or service as needed.
2. We provide 30 days warranty starting from the time you receive the item. Each customer must provide a record of their order such as the order number, or item receipt for any items that are out of the warranty period you may also still receive.
3. Replacement parts by purchasing them with our company if they are available.