

CROSLEY
FURNITURE

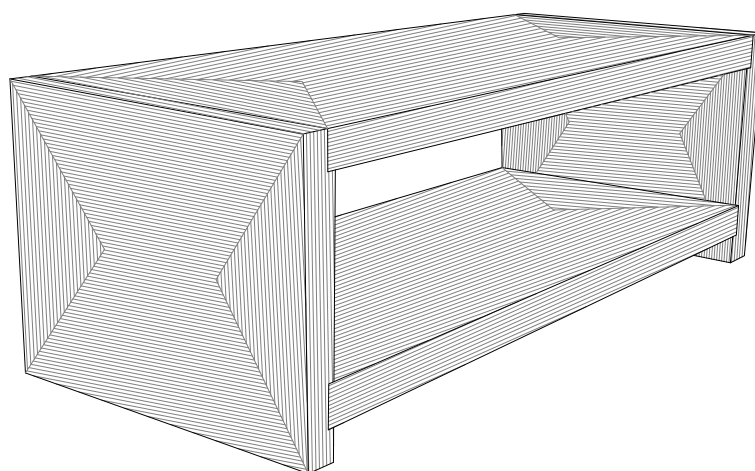

Coffee Table
CF1350

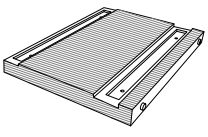
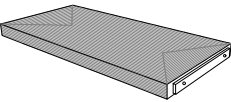
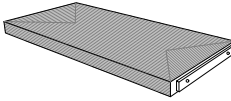

PART LIST

<p>A</p> 	<p>B</p> 	<p>C</p> 
<p>Side Panel 2 PCS</p>	<p>Top 1 PC</p>	<p>Shelf 1 PC</p>

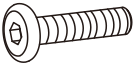
HARDWARE LIST

<p>#1</p>  <p>1/4"x2"</p>	<p>#2</p> 	<p>#3</p> 
<p>Bolt 8 PCS (Extra 1PC)</p>	<p>Flat Washer 8 PCS (Extra 1PC)</p>	<p>Allen Wrench 1 PC</p>

Step 1. Attach top (part B) to side panel (part A) using bolts (part #1), flat washers (part #2) and allen wrench (part #3).

NOTE: Please do not fully tighten bolts until unit is fully assembled.

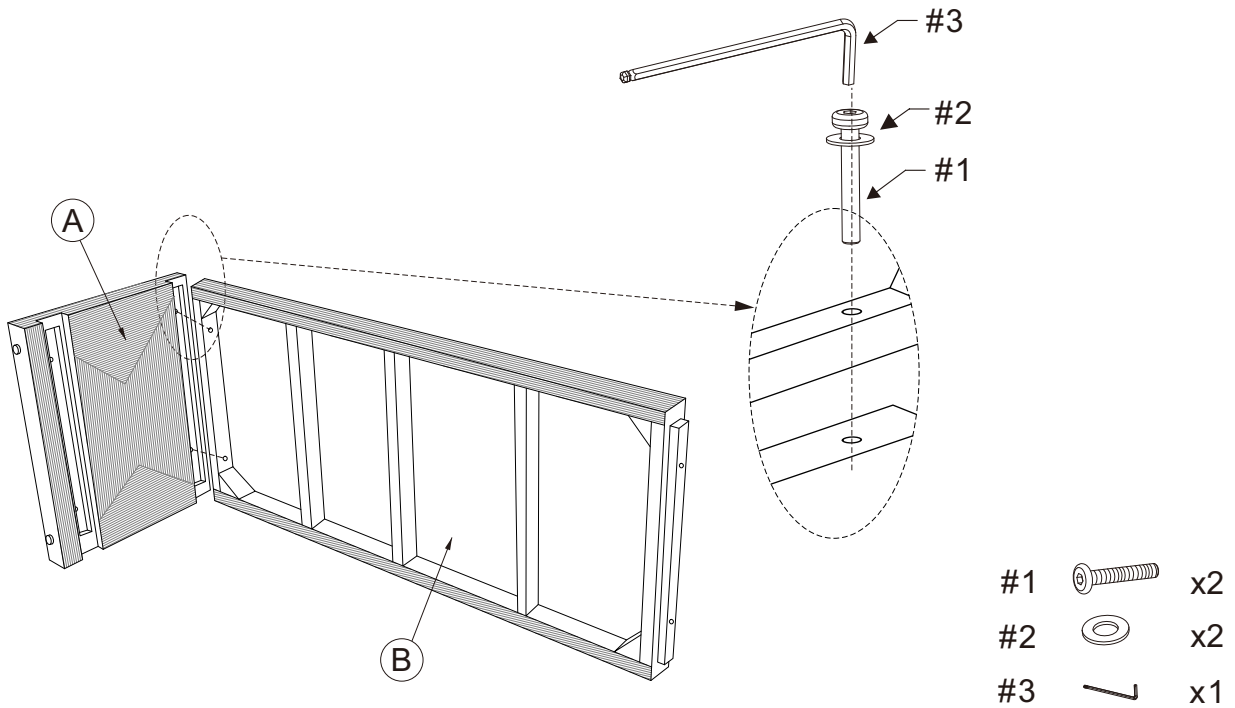

Step 2. Attach shelf (part C) to side panel (part A) using bolts (part #1), flat washers (part #2) and allen wrench (part #3).

NOTE: Please do not fully tighten bolts until unit is fully assembled.

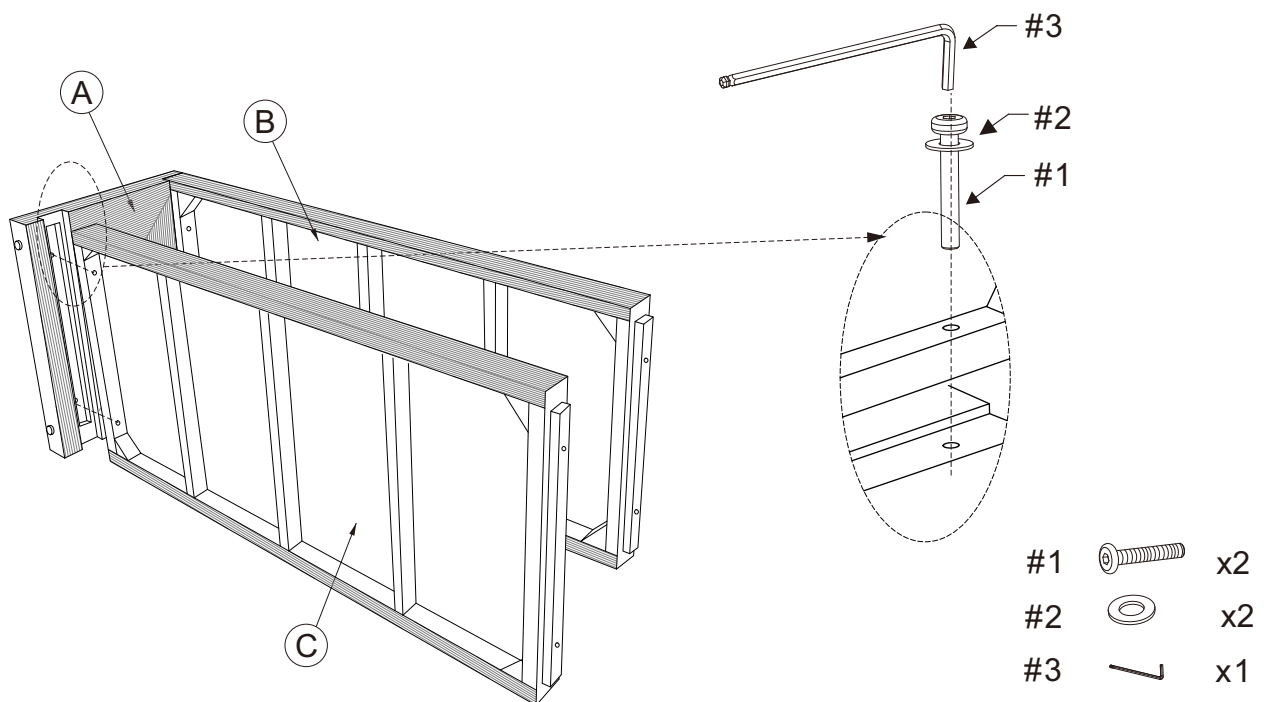

Step 3. Attach side panel (part A) to assembled unit (parts B & C) using bolts (part #1), flat washers (part #2) and allen wrench (part #3).

NOTE: Please fully tighten all bolts at this time.

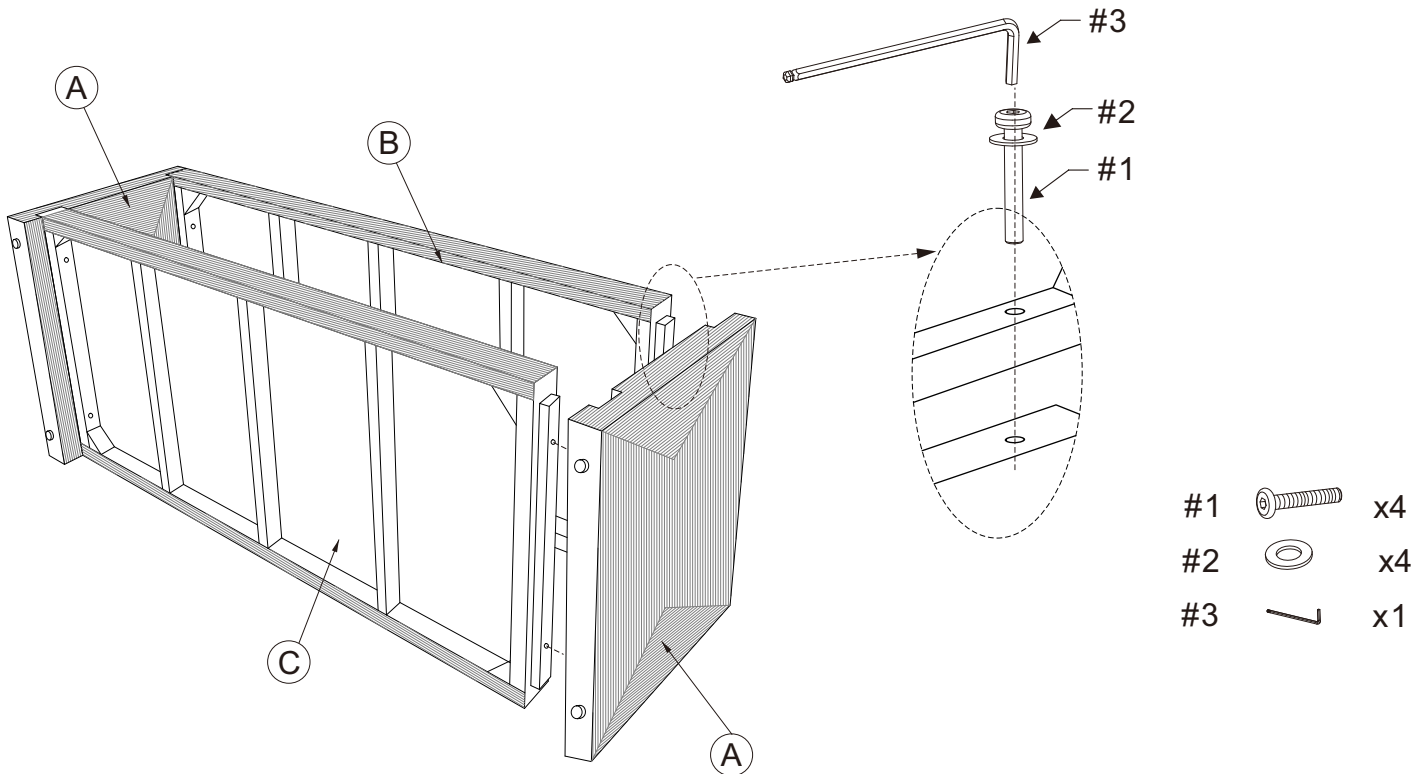

Step 4. Carefully turn unit upright.

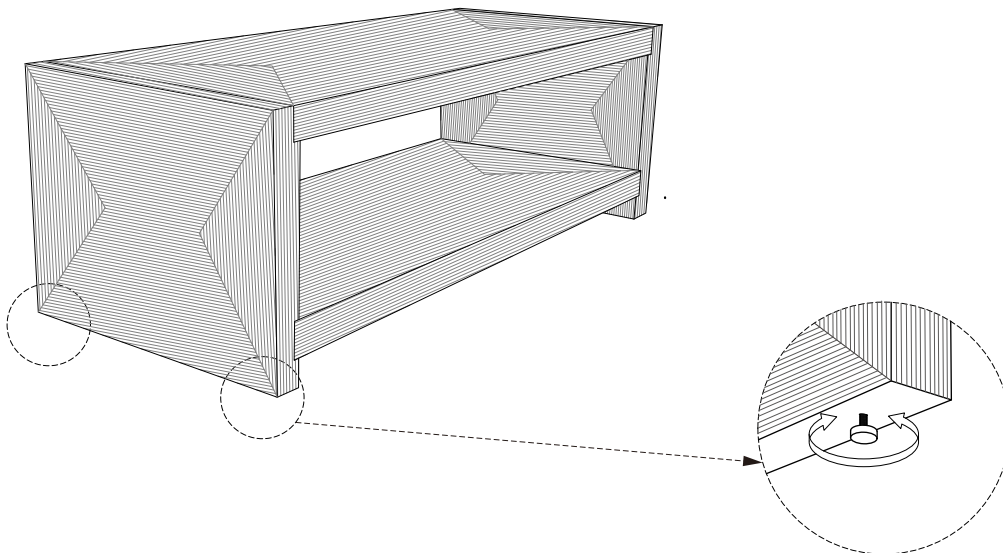

NOTE: It is important to adjust levelers once fully assembled and upright. Extend adjustable leveler until it's firmly in contact with the floor. If relocating, adjust leveler as needed until it's firmly in contact with the floor in new location.