

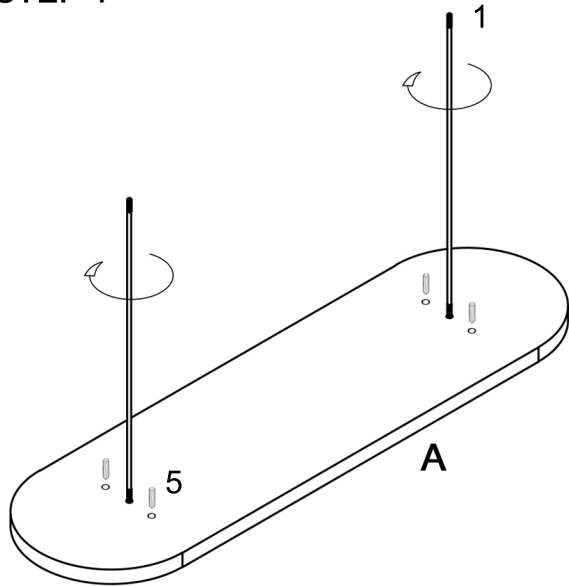



THANK YOU FOR PURCHASING THIS QUALITY PRODUCT.  
BE SURE TO CHECK ALL PACKING MATERIAL CAREFULLY FOR SMALL PARTS THAT MAY HAVE COME LOOSE INSIDE THE CARTON DURING SHIPMENT.





**STEP 1**



**PART LIST**

NO	DECS	SIZE (MM)	SKETCH	QTY
A	TOP	1400*700*35		1PC
B	TABLE LEG-1	Φ200*725		1PC
C	TABLE LEG-2	300*150*725		1PC

**HARDWARE LIST**

NO	DECS	SIZE (MM)	SKETCH	QTY
1	LONG BOLT	M8*745		2PCS
2	NUT	M8		2PCS
3	FLAT WASHER	Φ22*1.5*Φ12		2PCS
4	HEXAGON SOCKET	14#		1PC
5	WOODEN TENON	M8*30		4PCS

**STEP 2**

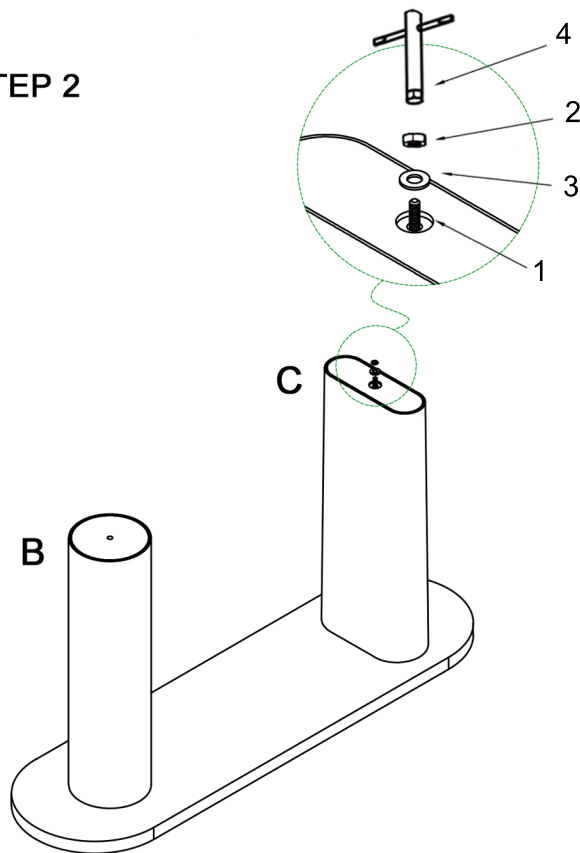

**FINISHED**

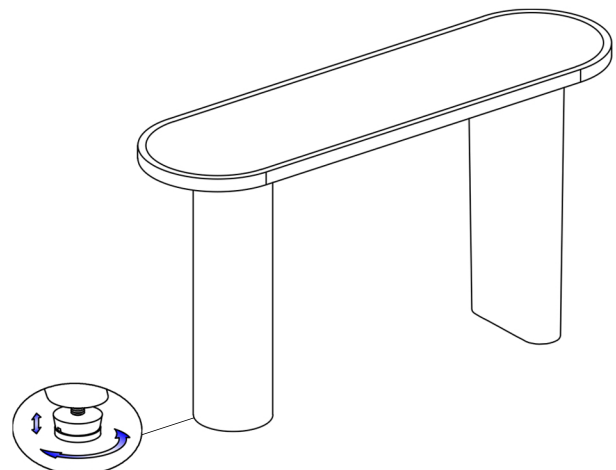

Adjustable glides are under the table legs,  
adjust it if needed.

MADE IN CHINA



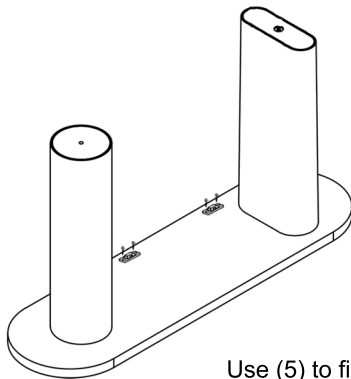
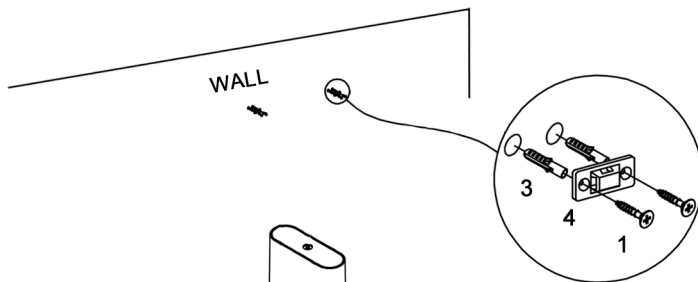

## STEP 1

Locate and mark on the wall behind the furniture. Position (4)s on the wall and drill holes. Put (3) in the hole then use (1) to attach the panels (4) to the wall.



Use (5) to fix (4) on the back of the table top.

## HARDWARE LIST

NO	DECS	SIZE (MM)	SKETCH	QTY
1	SCREW	M4*25		4PCS
2	CABLE TIES			2PCS
3	EXPANSION SCREW			4PCS
4	MOUNTING PANEL			4PC
5	SCREW	M4*16		4PCS

## STEP 2

Move the furniture to the marked position, then tie them up and fasten (2) to ensure the furniture is well-attached to the wall.

