

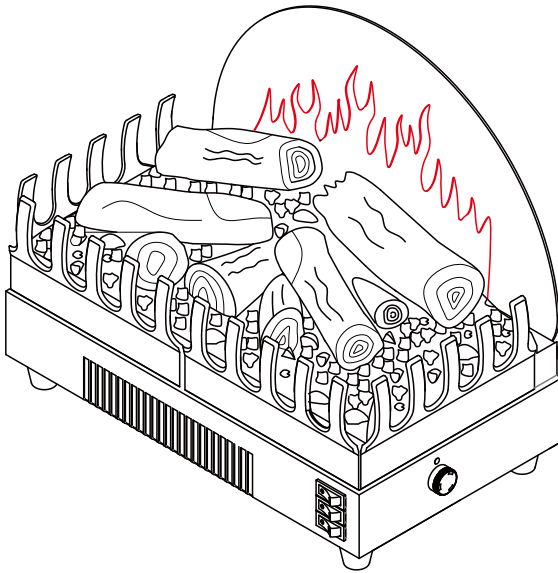

# ELECTRIC FIREPLACE LOGSET

**MODEL: EF361B**

## OWNER'S MANUAL



 <b>WARNING</b>	Read and understand this entire owner's manual, including all safety information, before plugging in or using this product. Failure to do so could result in fire, electric shock, or serious personal injury.
 <b>CAUTION</b>	Keep this owner's manual for future reference. If you sell or give this product away, make sure this manual accompanies this product.

**DO NOT RETURN!**

Contact our customer service team for help first.

[service2@richenchina.com](mailto:service2@richenchina.com)

Call: 909-206-6608



# IMPORTANT SAFETY INFORMATION

- Read all of the instructions before using this appliance.
- This heater is hot when in use. To avoid burns, DO NOT let bare skin touch hot surfaces. If provided, use handles when moving this heater. Keep combustible materials, such as furniture, pillows, bedding, papers, clothes, and curtains at least 3 feet (0.9m) from the front of the heater, and keep them away from the sides and rear.
- Extreme caution is necessary when any heater is used by or near children or invalids and whenever the heater is left operating and unattended.
- DO NOT operate any heater with a damaged cord or plug or after the heater malfunctions, has been dropped or damaged in any manner. Discard heater, or return to authorized service facility for examination and/or repair.
- DO NOT insert or allow foreign objects to enter any ventilation or exhaust opening, as this may cause electric shock or fire, or damage the heater.
- INDOOR use only! NEVER use this heater outdoors! Doing so may result in electric shock!
- To disconnect heater, turn controls to off, and turn off power to heater circuit at main disconnect panel (or operate internal disconnect switch if provided).
- To prevent a possible fire, DO NOT block air intakes or exhaust in any manner. Doing so could cause a fire. DO NOT use on soft surfaces, like a bed, where openings may become blocked.
- A heater has hot and arcing or sparking parts inside. DO NOT use it in areas where gasoline, paint, or flammable liquids are used or stored.
- Connect to properly grounded outlets ONLY.

- Use this heater only as described in this manual. Any other use not recommended by the manufacturer may cause fire, electric shock, or injury to persons.
- DO NOT place the heater near a bed because objects such as pillows or blankets can fall off the bed and be ignited by the heater.
- NEVER use this heater in bathrooms, laundry rooms, or any other location where the heater could fall into a bathtub or pool, become damp, or come in contact with water.
- AVOID FIRE! Regularly inspect all air vents to make sure they are free from dust, lint, or other blockage. Unplug the unit and clean with a vacuum ONLY. DO NOT rinse or get wet.
- WARNING: REDUCE THE RISK OF FIRE OR ELECTRIC SHOCK---DO NOT USE THIS HEATER WITH ANY SOLID STATE SPEED CONTROL DEVICES.
- For residential use only! NOT for commercial use! Any commercial or public use of this heater voids all warranties, and could cause injury.
- This product is not intended to be a primary heat source. It is for supplemental heat only.
- NEVER modify this heater. Doing so could result in personal injury or property damage. Modification of this fireplace completely voids all warranties.
- Hyperthermia can result in death. Symptoms of hyperthermia include high body temperature, headache, nausea, vomiting, tiredness, dizziness, fainting, and rapid pulse. If you begin to experience symptoms related to hyperthermia, **turn off** the heater and seek medical attention.
- To avoid excessive room temperatures which can cause hyperthermia: **DO NOT** leave product running unattended in a confined space around infants, or individuals with reduced physical, sensory, or mental capabilities.

- ALWAYS disconnect this unit from the power supply before performing any assembly or cleaning, or before relocating the electric fireplace.
  - NEVER leave this heater unattended. ALWAYS unplug this heater when not in use.
  - ALWAYS store this heater in a dry location. NEVER use the fireplace if it has become wet.
  - ONLY use this heater on a 120V AC 15 Amp circuit. NEVER overload the circuit. If this heater trips the circuit breaker, unplug all other appliances on the same circuit before the next use. Avoid plugging other appliances into the same circuit as this heater.
  - NEVER plug this heater into an outlet that is old, cracked, or has any loose wires or connections. Plugging this heater into a faulty outlet could result in electric arcing within the outlet that could cause the outlet to overheat or catch fire.
  - ALWAYS check your heater cord and plug connections with each use!
1. MAKE SURE the plug fits tight in the outlet! Faulty wall outlet connections or loose plugs can cause the outlet to overheat.
  2. Heaters draw more current than small appliances. Overheating may occur even if it has not occurred with the use of other appliances.
  3. During use check frequently to see if the plug outlet or faceplate is HOT!
  4. If the outlet or faceplate is HOT, discontinue use immediately and have a qualified electrician inspect and/or replace the faulty outlets.

## SAVE THESE INSTRUCTIONS!

# TECHNICAL SPECIFICATIONS

## MODEL NO.: EF361B

Supply Voltage: AC120V 60Hz

Maximum power consumption: 1.5KW

Power for flame and fuel bed effect: 5.44W

## PARTS AND HARDWARE

- Unpack the firecarefully, make sure that the appliance is intact with no signs of damage caused by transport and no part has been exposed to water. If in doubt, do not use the appliance and contact an authorized service center.
- Keep plastic wrapping away from children.
- Save the original packaging as this may be required in the event of service complaint with product.
- Check that all parts are removed from the packaging.

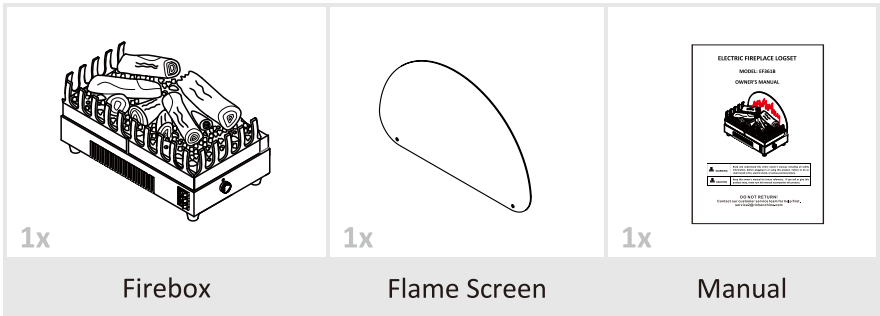

Please refer to section **OPERATION INSTRUCTION** part to test the appliance first before installation. Should any defects found, please contact service team for help. Call 909-206-6608 or Email [service2@fireandfireplaceservice.com](mailto:service2@fireandfireplaceservice.com).

# APPLIANCE DIMENSIONS

Unit: inches

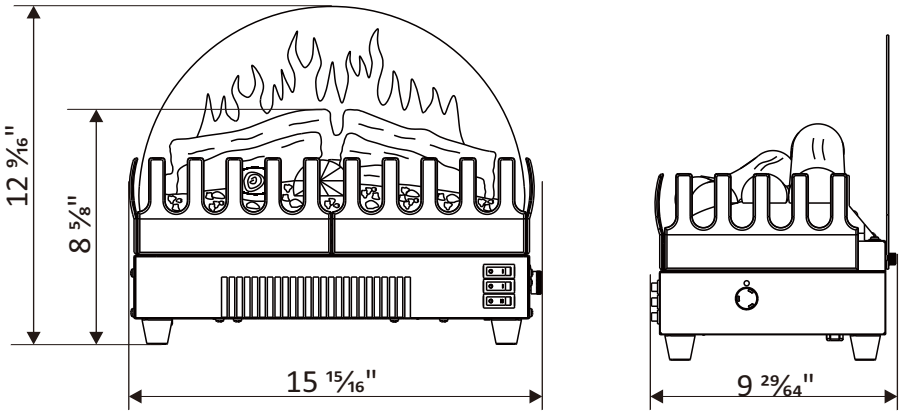

## INSTALLATION INSTRUCTIONS

### Locating the Appliance

Your new electric fireplace may be installed virtually anywhere in your home. However, when choosing a location ensure that the general instructions are followed.

- For best results, install out of direct sunlight.
- The appliance should be connected to an earthed electrical outlet and it must be easily accessible to allow disconnection.

### Prepare the electrical supply

- Plan the location of the appliance so that it will have adequate electric power. A 15 AMP, 60Hz circuit is required for 120V installation. The appliance should ideally be located close to a suitable main socket to enable power connection.
- The power cord is 6ft long and locates on the right bottom of the unit. If the cord is found not long enough to reach the outlet, a

grounded extension could be run from an existing socket outlet but a minimum size 14 AWG with a minimum rating 1875W would be recommended, and it should not be longer than 7ft and 10 31/64".

- Always make sure the outlet is in good condition and the plug is not loose. NEVER exceed the maximum amperage of the circuit.

### Installing the Appliance

Fix the flame screen by two screws attached on the back.

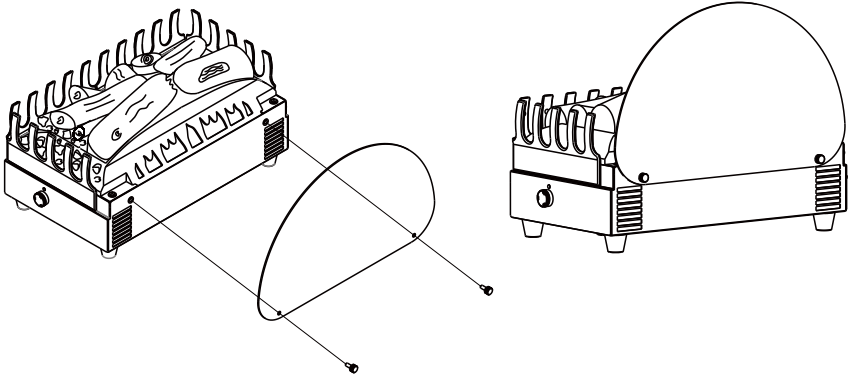

## OPERATING INSTRUCTION

### 1. GENERAL

**WARNING!** Do not operate the appliance if it is damaged or has mal-functioned. If you suspect the appliance is damaged or has malfunctioned, call a qualified service engineer to inspect the appliance, and replace any part of the electrical system if necessary, before re-use.

**WARNING!** To reduce the risk of fire, keep textiles, curtains, or any other flammable material a minimum distance of 1 meter from the air outlet.

- **MAKE SURE** the plug fits tight in the outlet. Faulty wall outlet connections or loose plugs can cause the outlet to overheat.
- **DO NOT** disconnect the power at the mains supply whilst the appliance is running. Use the functions on the remote to turn the fire off and ensure the mains switch has been moved to the off position before disconnecting.

## 2. MANUAL CONTROL PANEL

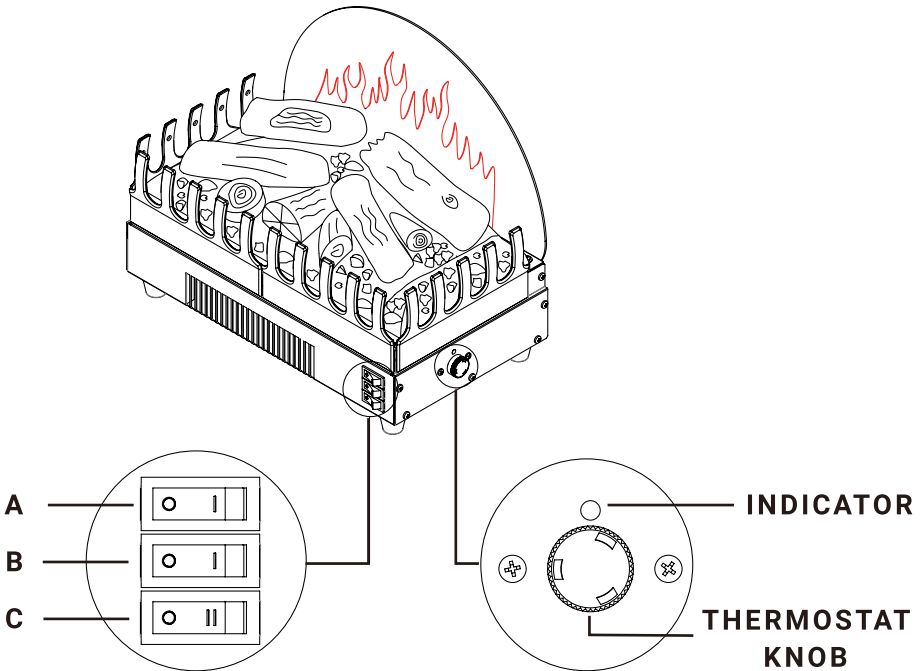

BUTTON	FUNCTION
SWITCH A	Press “I” to turn on the flame effect and fuel bed effect. Press “O” to turn off the appliance.
SWITCH B	Press “I” to turn on half power heating (750 w). Press “O” to turn off it. NOTE: this function is only effective when switch A is at ON position “I”.
SWITCH C	Press “II” to turn on full power heating (1500 w). Press “O” to turn off it. NOTE: this function is only effective when both switch A and Switch B are at ON position “I”
THERMOSTAT	<p>It can be used to control the heat output to maintain a constant room temperature to suit user requirements.</p> <p>This will ensure that excessive heat is not produced unnecessarily. The dial is marked with numbers to indicate the maximum and minimum temperature positions. Start with setting 9 and when the room has reached a desired level turn the dial slowly to the left until the thermostat 'clicks' off. The thermostat will then maintain the room temperature at the selected level. To increase the temperature, turn dial back to the right to a higher setting.</p>

# CLEANING

**WARNING!** ALWAYS turn the heater OFF and unplug the power cord from the outlet before cleaning, performing maintenance, or moving this fireplace. Falso do so could result in electric shock, fire, or personal injury.

**WARNING!** NEVER immerse in water or spray with water. Doing so could result in electric shock, fire, or personal injury.

## METAL:

- Buff using a soft cloth, slightly dampened with a citrus oil-based product.
- DO NOT use brass polish or household cleaners as these products will damage the metal trim.

## PLASTIC:

- Wipe gently with a slightly damp cloth and a mild solution of dish soap and warm water.
- NEVER use abrasive cleansers, liquid sprays, or any cleaner that could scratch the surface.

## Vents:

- Use a vacuum or duster to remove dust and dirt from the heater and vent areas.
- Clean the exterior of the fireplace with a slightly damp cloth or duster.

# MAINTENANCE

**WARNING!** Risk of electric shock! DO NOT OPEN! No user-serviceable parts inside!

## Electrical and Moving Parts:

- The fan motors are lubricated at the factory and will not require lubrication.
- Electrical components are integrated in the fireplace and are not serviceable by the consumer.

## Replacement parts:

- Use only replacement parts supplied by the manufacturer. Use of any other parts, or modifying the fireplace in any way, will void all warranties.

# LIMITED WARRANTY

This warrants to the original purchaser that this product is free from defects in material and workmanship as of the date of purchase and that it will, under normal use and proper care, remain so for one year from the date of purchase. Missing or initially defective parts will be replaced free of charge during the period of this limited warranty. If parts are unavailable, comparable replacement or refund will be given. **The original dated sales receipt is required for all warranty claims.** This warranty does not cover damage which has occurred during transport from the point of purchase to the consumer's home. This warranty does not cover glass, light bulbs, batteries, transportation, labor, or other issues not associated with the manufacture of the product.

**This product is for residential use only. Any and all commercial use of this product voids all warranties, and frees the manufacturer from all liability.**

Read and understand all assembly and operating instructions, and all safety information and warnings, before use. The following will void this warranty: Damage caused from tampering with, modifying, or altering the fireplace insert in any manner; Damage due to incorrect assembly, improper care, misuse, or abuse; Damage from being used with the wrong power source; Water damage; Damage caused from this insert being used outdoors; Damage caused from this insert being used for excessive periods of time; Damage caused by the insert being used in a commercial application; Damage from use as a primary heat source; Other misuse or abuse not specifically listed herein.

**This product is not intended to be used as a primary heat source. It is for supplemental heating purposes only.**





**Ningbo Richen Electrical Appliance Co., Ltd**  
**Address: No.19, Yongdinghe Road, Xiapu, Beilun, Ningbo PR. China**