

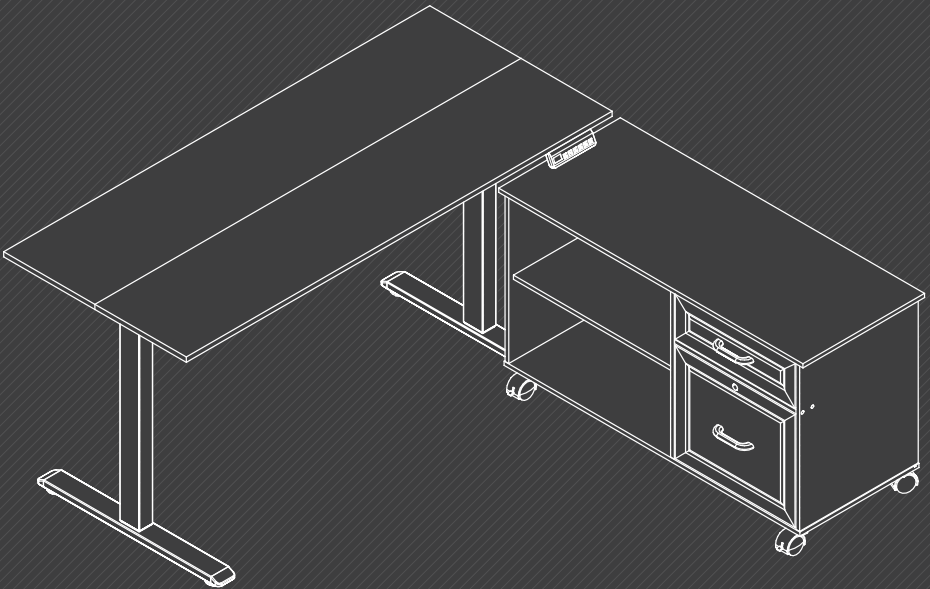

# STANDING DESK WITH CABINET



USER MANUAL



# Safety Instructions

## Thank You For Choosing Our Product

Before assembly, please read this USER MANUAL first, and check according to Parts List to make sure all parts are included.

Feel free to contact us if you have any concerns or questions about your product, we are always ready to help. Your satisfaction is our first priority!

## Precautions

### BEFORE YOU BEGIN THIS INSTALLATION

Thoroughly read all instructions for both safety and usage prior to installations.



1. Avoid long-term direct sunlight exposure.

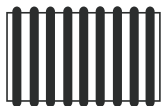

2. Keep away from heat.

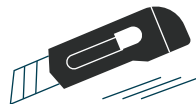

3. Keep away from sharp objects.



4. Keep infants/children away from assembly parts to avoid choking and suffocation.



5. Keep away from corrosive substances.

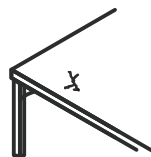

6. Pay attention to avoid over-tightening fasteners, or they may induce cracking within the board.

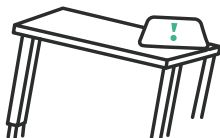

7. Keep weight on desk balanced for correct operation and longer life of components.

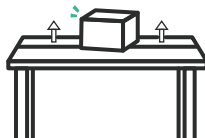

8. Keep area of vertical motion free of obstacles.

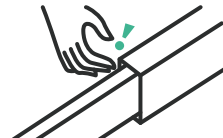

9. Do not place hands on or near support bars. Moving parts can crush and cut.

# Safety Instructions

## SAFETY AND WARNINGS

1. Inappropriate use of this product may cause property damage or bodily injury.
2. Check surroundings on all sides before using the desk. Body parts and property can be crushed if trapped between an immobile obstacle and the desk's range of motion.
3. Ensure the length of power cords are accounted for when operating the desk. Monitors, computers, speakers, anything with a cord that is not long enough for the desk's range of motion could be pulled down or have its wires broken.
4. Items pulled off the desk may cause other items to fall.
5. Please provide this operating manual to any users, installers, or support personnel operating the product.
6. Do not place any objects taller than 20" underneath the desk.
7. Do not open any of the components, the Legs, Control Box, or Switch. There is a danger of electric shock.

## USAGE

This height adjustable desk has an electric motor and is designed for use in dry work areas only.

The desk height is adjustable so that it can be positioned at the ergonomically desired height.

These desks are designed only for the purposes included in this manual. They should not be used in environments where there is high humidity or in areas with dampness. Any other environments are at user's own discretion.

Do not move around, crawl or lie under the desk frame. Do not sit or stand on the desk frame.

Children should never use the desk without parental supervision.

Liability: Under no circumstances does the manufacturer accept warranty claims or liability claims for damages caused from improper use or handling of the desk frame other than that which is described in this operation manual.

## SETUP AND INSTALLATION

Once the desk has been assembled, adjust the feet so that the desk is level and does not shift its position.

After this, connect the desk to the 110v or 220v outlet and the desk is ready for use.

Check that no cables can get twisted or jammed.

Choose a proper placement for the desk that's a safe distance from window frames, radiators and/or furniture so that people do not get lodged or trapped by the desk.

When moving the desk after it has been fully assembled, DO NOT lift the desk by the desktop.

Lifting this way can stress the fasteners connecting the desk base to the desktop.

Lower the desk completely and lift the desk by grabbing the top of the desk base or by removing the desktop first.

### WASTE DISPOSAL



This marking indicates that this product should not be disposed with other household wastes. To prevent possible harm to the environment or human health from uncontrolled waste disposal, recycle it responsibly to promote the sustainable reuse of material resources. To return your used device, please use the return and collection systems or contact the retailer where the product was purchased. They can take this product for environmental safe recycling.

# Description of faults

Troubleshooting	Trouble Code	Description	Troubleshooting
Resistance Protection	E02	If resistance is suddenly encountered during operation, the LED display will show and flash "E02"; the table will stop moving and then move 40mm in the opposite direction, and the LED display will show the actual height.	Clean up the obstruction in the lifting process, and then keep pressing the "⊕" button until it displays "⊖" Then, you can release the button so that the standing desk can be used normally after being reset.
Overheat Protection	Hot	Continuous long-time operation may cause this protection to be activated.	Re-energize or wait at least 15 minutes before use.
Motor Abnormal Protection	E10	In any case of disconnection/loosening of wires, the motor fails, and the LED display flashes "E10".	After disconnecting the power, recheck and make sure that the connection between the motor and the controller is secure, and then reapply the power.
Overload Protection	E20	When the load exceeds the set value (under normal circumstances, the load should be controlled under 70 kg), "E20" is displayed and flashes on the LED display.	If this alarm occurs during upward operation, remove some of the weight on the table and run again; if this alarm occurs during downward operation, disconnect the power, remove some of the weight on the table, and re-energize the power.
Over-voltage Protection	E31 E32	<ol style="list-style-type: none"> <li>1. When the input voltage of the controller is lower than 34V, the LED screen displays "E31".</li> <li>2. When the input voltage of the controller exceeds 34V, the LED screen displays "E32".</li> </ol>	After power failure, recheck and make sure that the connection between the power supply and the controller is solid, and then re-power it; when the voltage drops to 34V, the system automatically recovers, and the LED displays the actual height.

## Description of faults

In the "E10, E20" alarm state or run to the lowest height position, long press the Ⓞ key for 3 seconds, and release the key after display (Reset), the standing desk will start to run down to the end and bounce a certain height, reset will be completed and the minimum height will be displayed.

If the table legs are not aligned but can be moved up and down, please contact the after-sales service in time. Unscrew the connecting nut, rotate the connecting rod and plastic-covered hexagonal rod to manually adjust the table legs to the initial state, and reinstall the fixed coupling rod.



## Problems You May Encounter

PART	PROBLEM	SOLUTION
DESKTOP	The table is uneven.	Loosen the screws, and adjust the corner of the table until it is stable, then tighten all of the screws.
	Wrong hole position.	Check if the panel is reversed.
	Uneven hole position.	Rotate each screw just a few turns. When all screws are threaded, go back and tighten all remaining screws.
	The desktop could not be lifted.	Check if overloaded, max loading: 70kg. Find after sales in time.
LEGS	Strange sound and shaking, incorrect assembly.	Check if all of the screws are 100% tightened.
	Only one side moves up and down.	Check whether the coupling is connected to two ports at both ends and whether the black circlip is still there. If the coupling rod can be pulled out, it means that it is not installed and not fixed. Reassemble the coupling rod, and reset the desk.
	Uneven legs but the desk can go up and down.	Find after sales in time. Remove the hexagonal coupling rod and rotate the coupling rod to adjust the table leg manually to the initial state.
MEMORY HEIGHT	Memory position button not work.	Once the desk is reset and displays 72, your desk is now ready to use.
ACCESSORIES	Not enough or inconsistent.	Find after sales in time.
MOTOR ISSUE	Error code E10 . Motor doesn't work.	Find after sales in time.
	Overwork (Duty cycle: Max 5min ON / 15min OFF)	Restart it after switching off for 15 mins for overworking. Find after sales in time.
POWER ISSUE	Handset doesn't display, and power indicator light is not on.	Find after sales in time.

# Disassembly Diagram

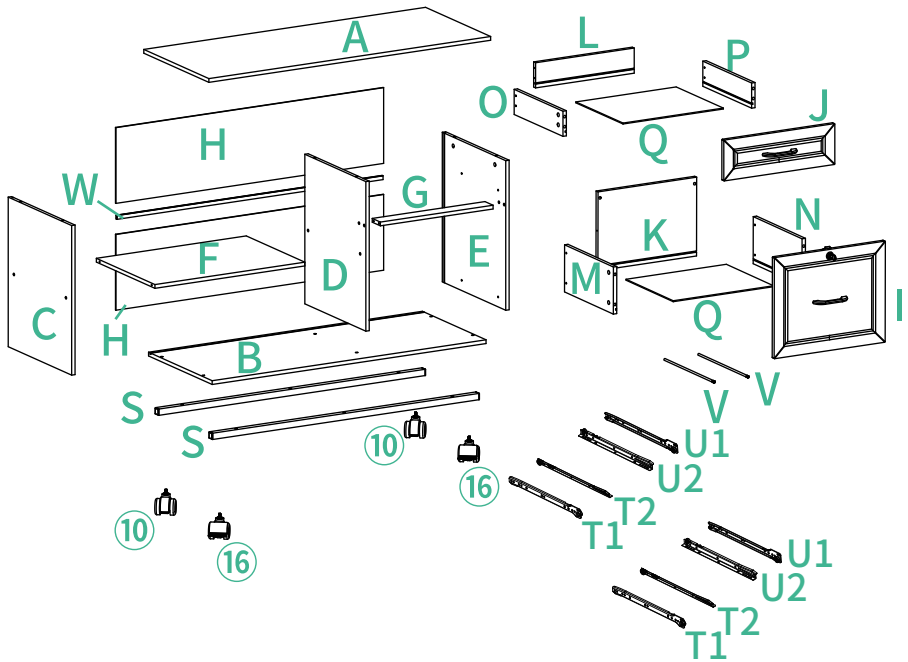

# Disassembly Diagram

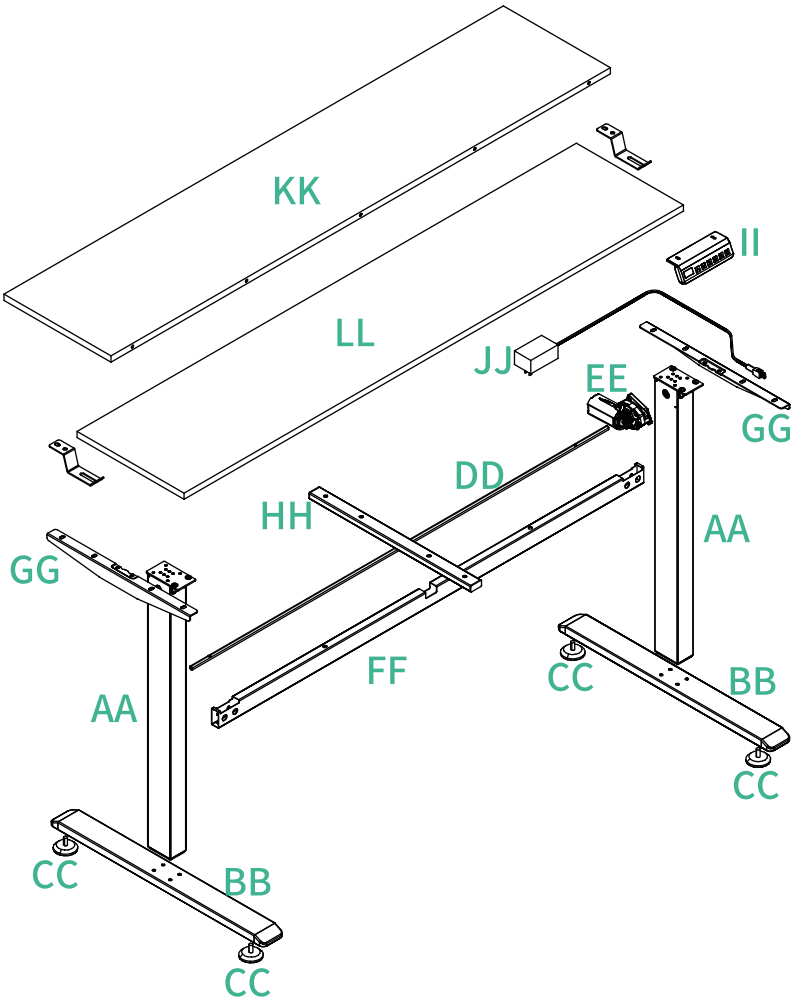





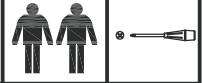

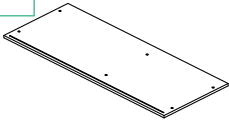
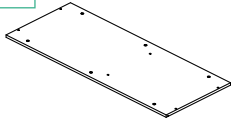
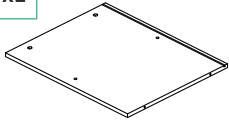
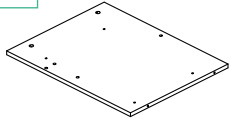
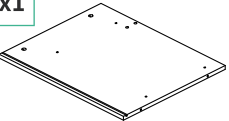
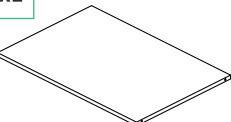
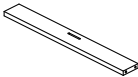
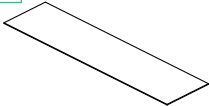
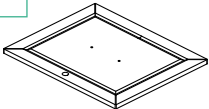
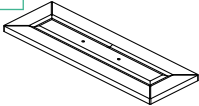
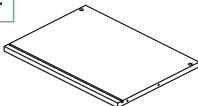
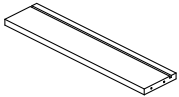
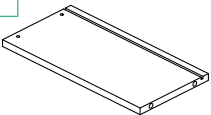
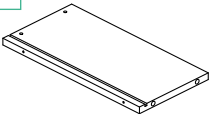
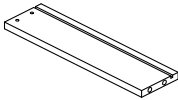
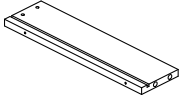
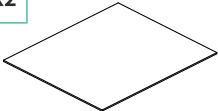
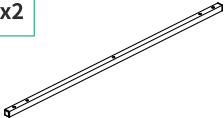
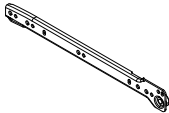
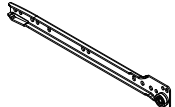
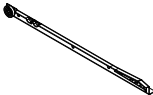
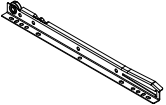



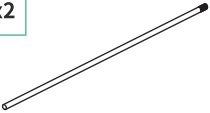
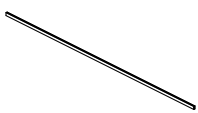
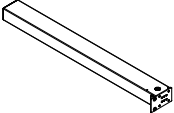
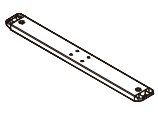

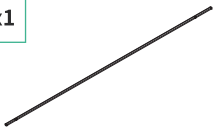
# Parts List

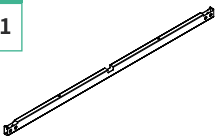
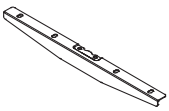
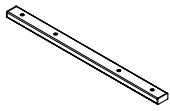
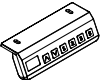
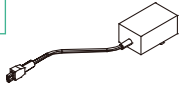
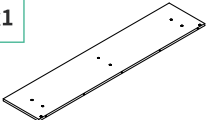
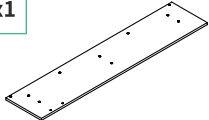
For ease and safety, we recommend two people for assembly.

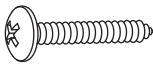

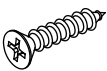

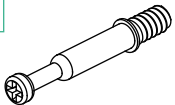





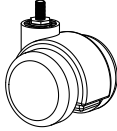
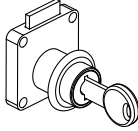



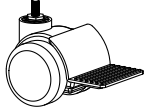
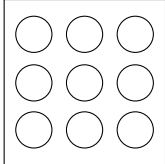



<b>A</b> x1 	<b>B</b> x1 	<b>C</b> x1 	<b>D</b> x1 
<b>E</b> x1 	<b>F</b> x1 	<b>G</b> x1 	<b>H</b> x2 
<b>I</b> x1 	<b>J</b> x1 	<b>K</b> x1 	<b>L</b> x1 
<b>M</b> x1 	<b>N</b> x1 	<b>O</b> x1 	<b>P</b> x1 
<b>Q</b> x2 	<b>S</b> x2 	<b>T1</b> x2 	<b>U1</b> x2 
		<b>T2</b> x2 	<b>U2</b> x2 

# Parts List



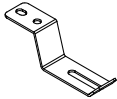



<b>V</b> x2 	<b>W</b> x1 	<b>AA</b> x2 	<b>BB</b> x2 
<b>CC</b> x4 	<b>DD</b> x1 	<b>EE</b> x1 	<b>FF</b> x1 
<b>GG</b> x2 	<b>HH</b> x1 	<b>II</b> x1 	<b>JJ</b> x1 
<b>KK</b> x1 	<b>LL</b> x1 	<b>MM</b> x1 	
<b>1</b> x7 	<b>2</b> x9 	<b>3</b> x5 	<b>4</b> x5 
<b>M6x23</b> 1 Spare	<b>ST4x35</b> 1 Spare	<b>ST4x20</b> 1 Spare	<b>ST4x16</b> 1 Spare
<b>5</b> x18 	<b>6</b> x9 	<b>7</b> x16 	<b>8</b> x16 
<b>ST4x10</b> 2 Spares	<b>ST3x14</b> 1 Spare	<b>2 Spares</b>	<b>2 Spares</b>

# Parts List

<p>9</p> <p>x2</p> 	<p>10</p> <p>x2</p> 	<p>11</p> <p>x1</p> 	<p>12</p> <p>x9</p>  <p>1 Spare</p>
<p>13</p> <p>x1</p> 	<p>14</p> <p>x1</p> 	<p>15</p> <p>x1</p> 	<p>16</p> <p>x2</p> 
<p>17</p> <p>x1</p> 	<p>19</p> <p>x9</p>  <p>M6x32</p> <p>1 Spare</p>	<p>20</p> <p>x5</p>  <p>M4x12</p> <p>1 Spare</p>	<p>21</p> <p>x5</p>  <p>M6x38</p> <p>1 Spare</p>
<p>22</p> <p>x5</p>  <p>M6x25</p> <p>1 Spare</p>	<p>23</p> <p>x23</p>  <p>M6x12</p> <p>3 Spares</p>	<p>24</p> <p>x3</p>  <p>M6x50</p> <p>1 Spare</p>	<p>25</p> <p>x2</p>  <p>M6x35</p> <p>1 Spare</p>
<p>26</p> <p>x6</p>  <p>φ6x40</p> <p>1 Spare</p>	<p>27</p> <p>x4</p> 	<p>28</p> <p>x1</p> 	<p>29</p> <p>x2</p> 
<p>30</p> <p>x16</p>  <p>ST6x50</p> <p>2 Spares</p>			

# Assembly Instructions

01



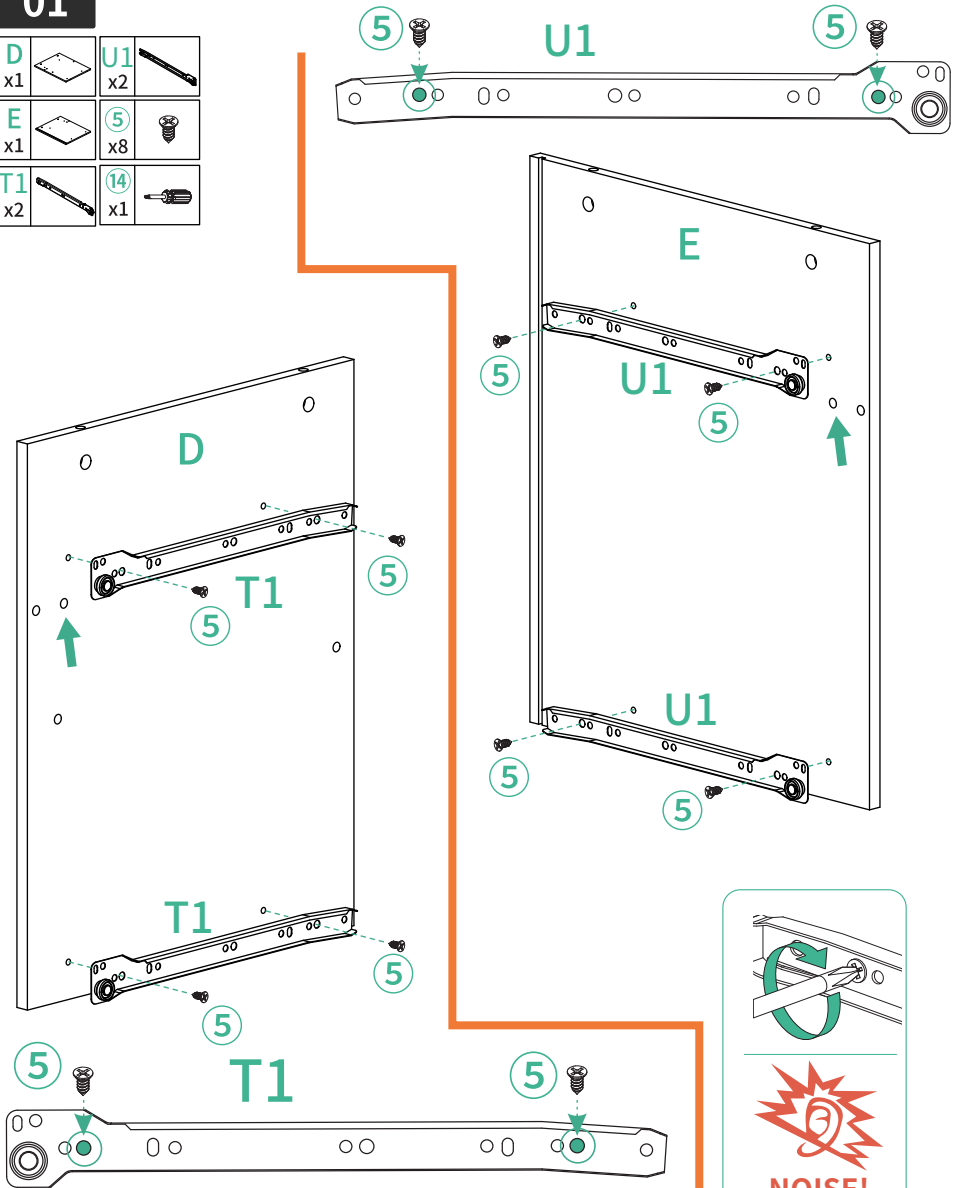



D x1		U1 x2	
E x1		(5) x8	
T1 x2		(14) x1	



Please tighten the screws, or the guide rail will make noise.

# Assembly Instructions

02

- A**  
x1 
- C**  
x1 
- E**  
x1 
- 8**  
x4 
- 7**  
x4 
- 14**  
x1 

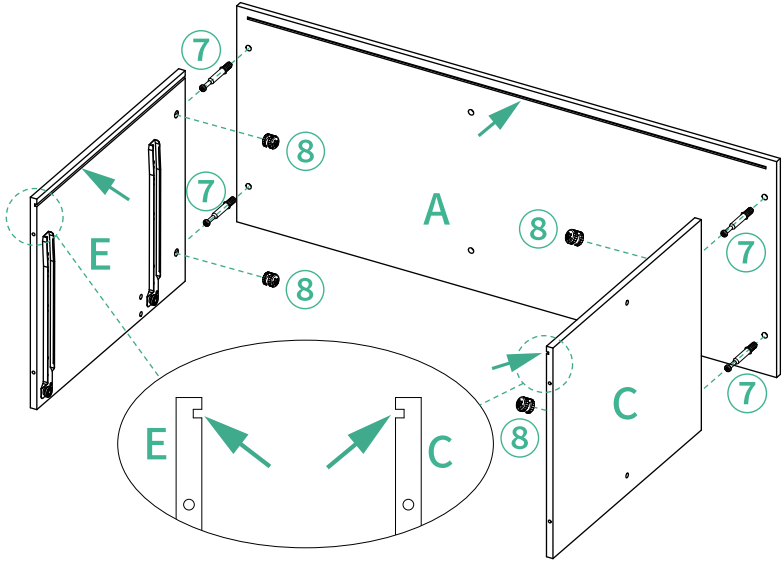

Installation instructions for parts 7 and 8.

**1**

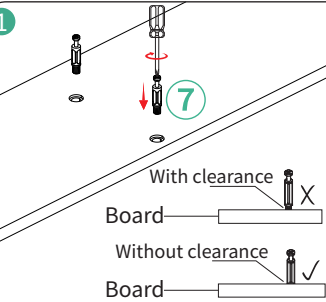

With clearance X  
Board ———  
Without clearance ✓  
Board ———

**2**

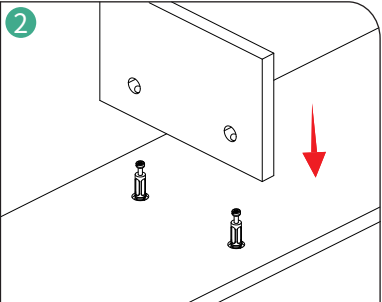

**3**

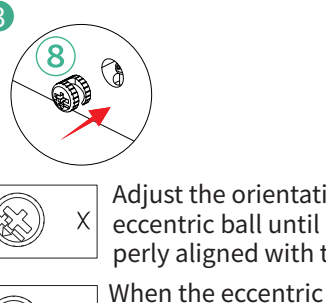

X  
Adjust the orientation of the eccentric ball until it is properly aligned with the hole.

✓  
When the eccentric ball is correctly oriented, insert the eccentric rod.

**4**

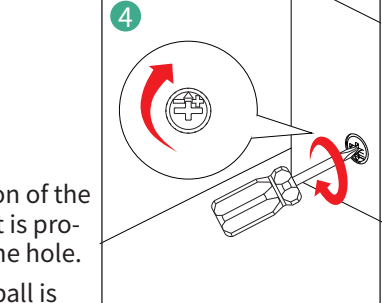

# Assembly Instructions

03

Keep the holes indicated by the arrows on the same side.

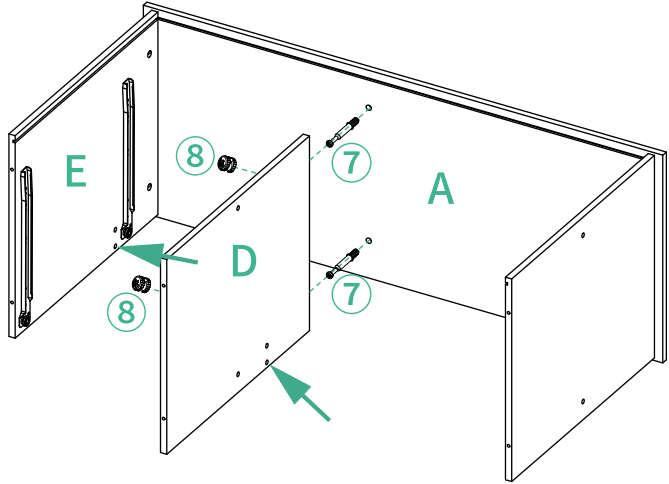
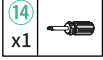
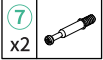

04

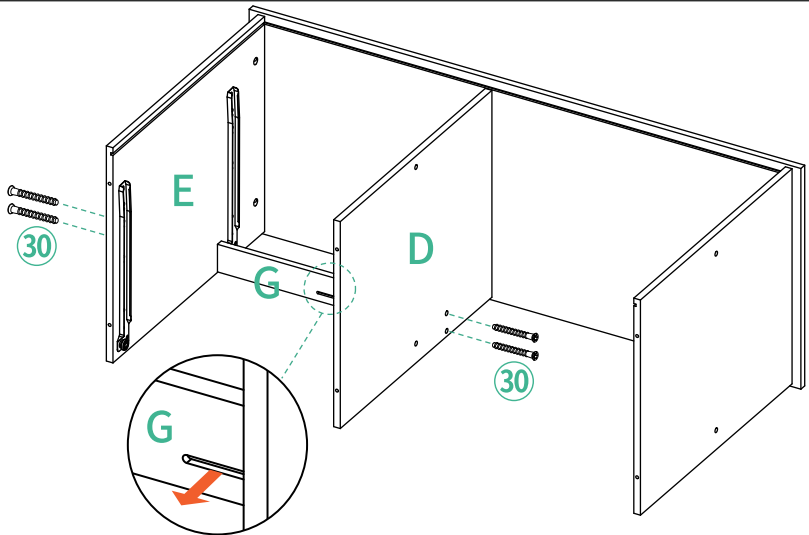
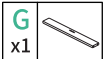

Please note: The holes indicated by the arrows face outwards, otherwise subsequent installation will be affected.

# Assembly Instructions

05

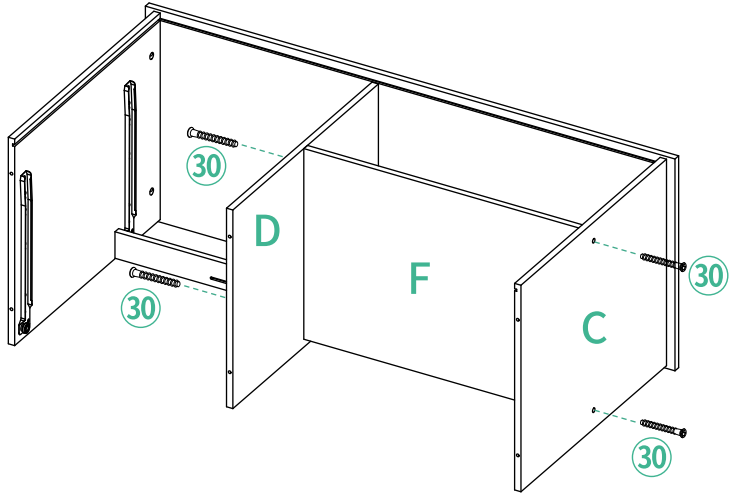

06

Please note: Parts H should be gently slid into the slot to prevent breaking.

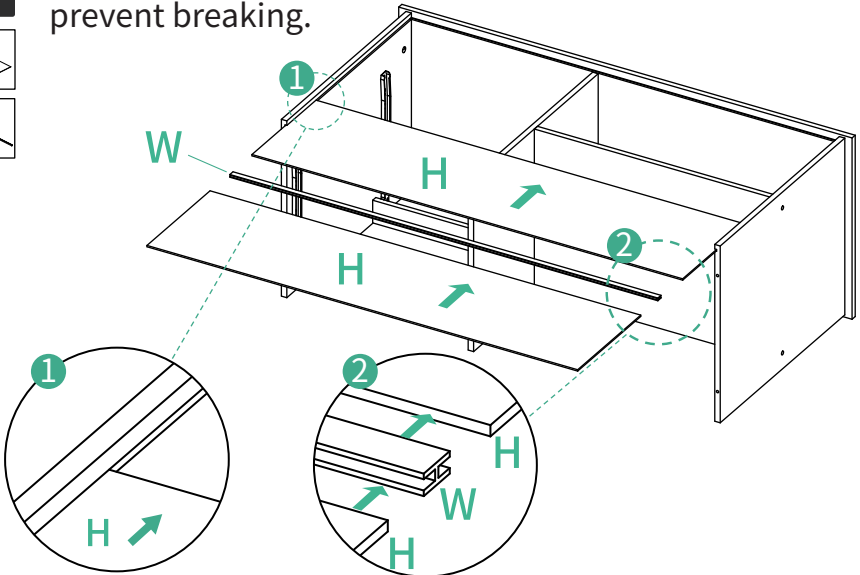

# Assembly Instructions

07

- B x1
- 30 x6
- 13 x1

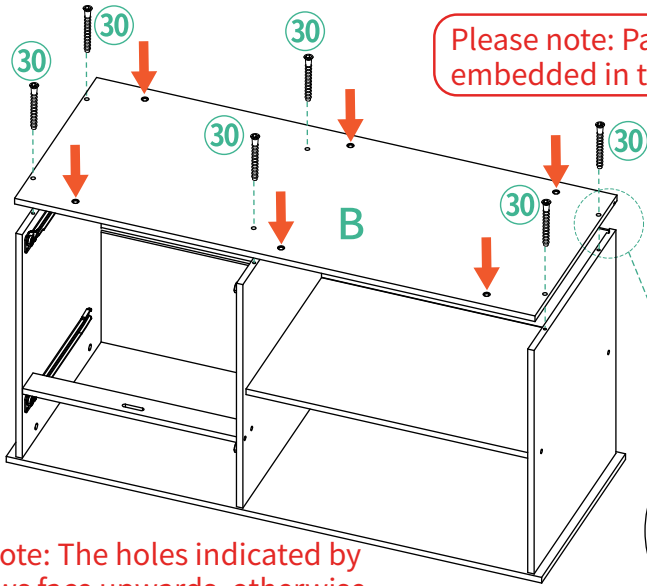

Please note: Part H needs to be embedded in the slot of Part B.

Please note: The holes indicated by the arrows face upwards, otherwise subsequent installation will be affected.

08

- S x2
- 16 x2
- 10 x2
- 15 x1

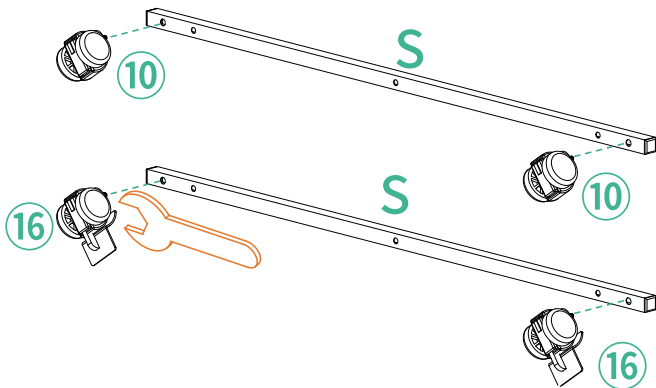

# Assembly Instructions

09

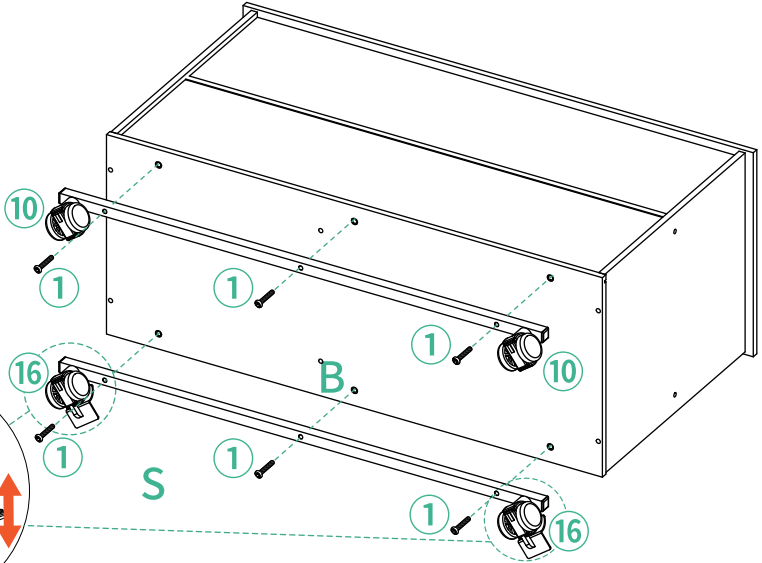

Toggle downward to hold the wheel in place, and upward to restore free movement of the wheel.

10

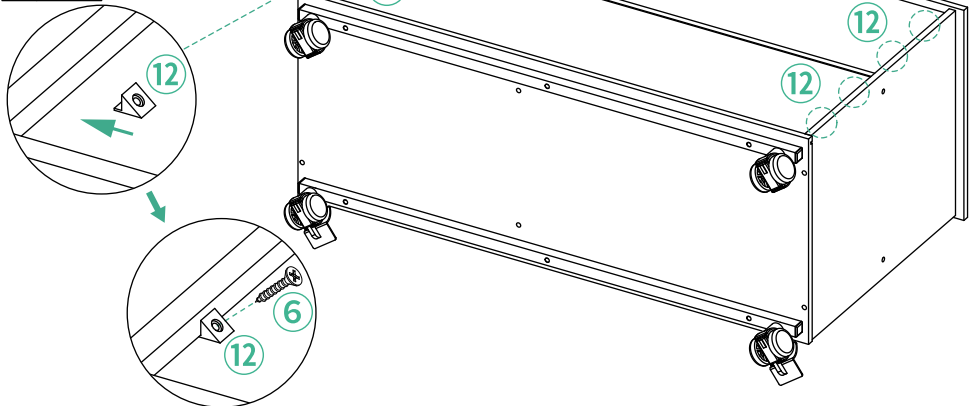
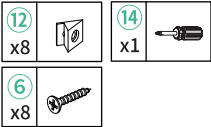

# Assembly Instructions

11

Please note: Ensure that the slot in the part indicated by the arrow is on the inside of the drawer, otherwise the installation of the drawer base Q will be affected.

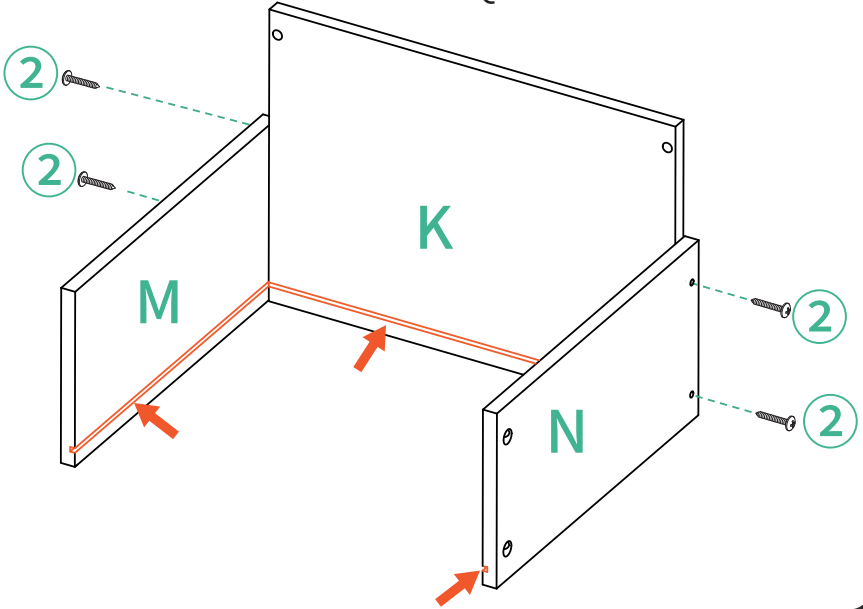
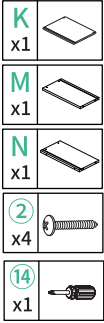

12

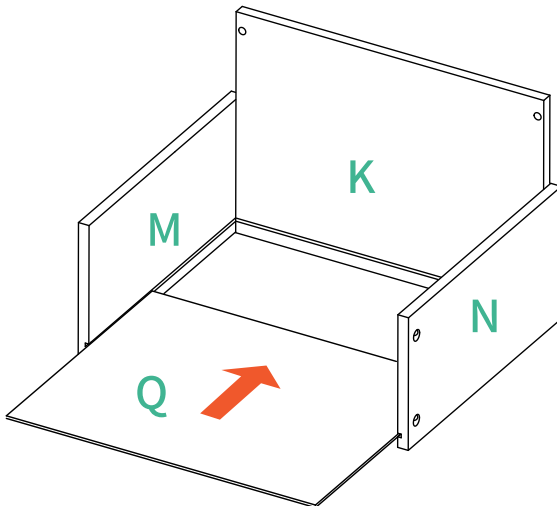
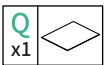

# Assembly Instructions

13

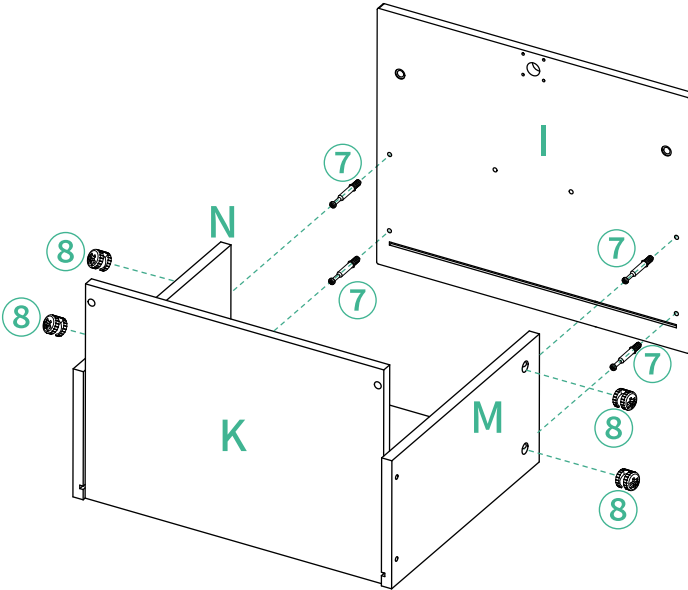
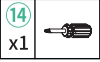
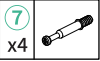

Installation instructions for parts 7 and 8.

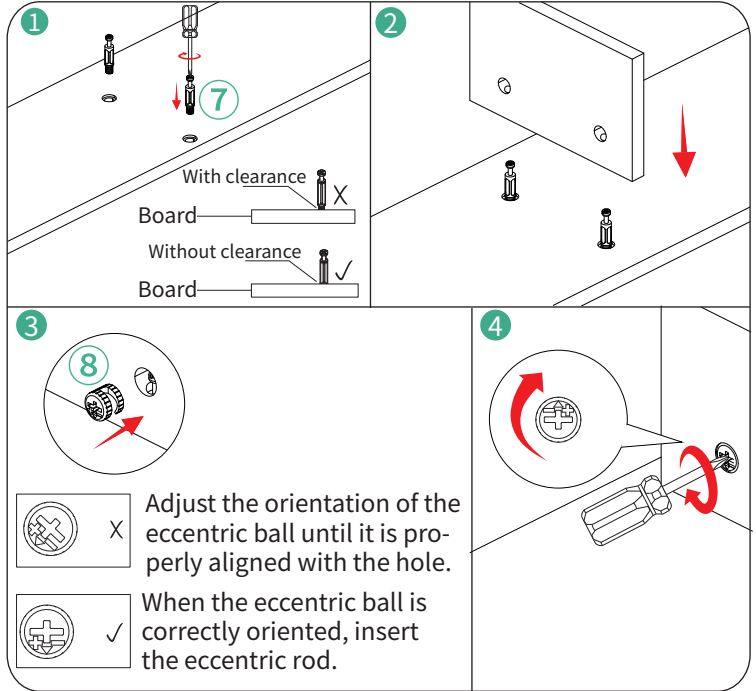

# Assembly Instructions

14

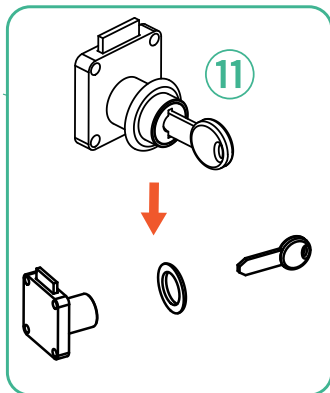
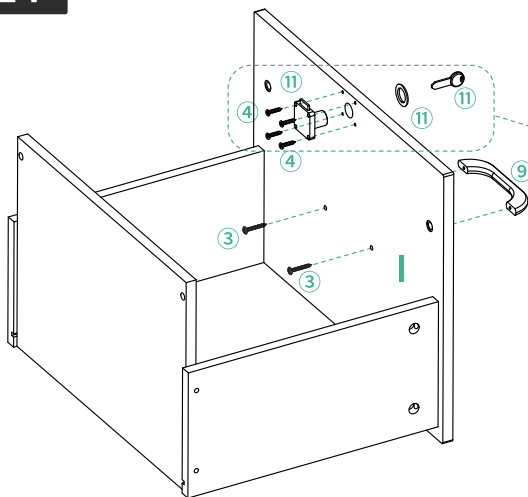

15

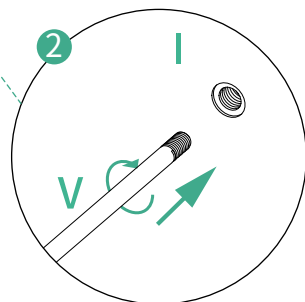
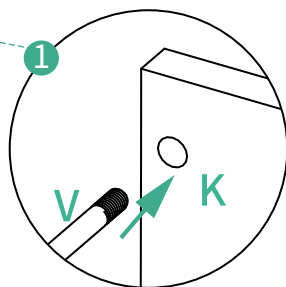
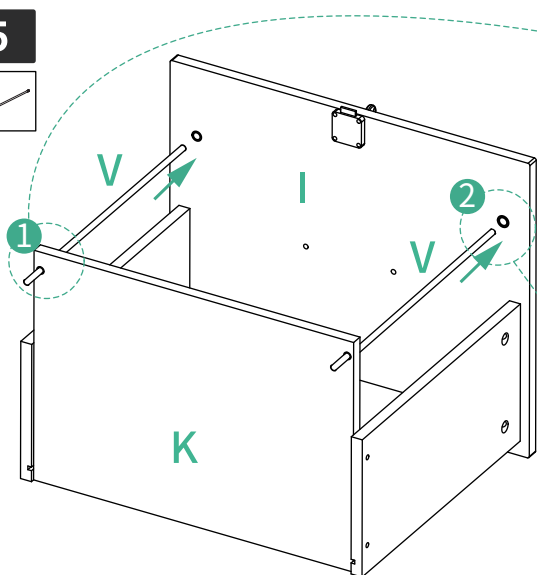



# Assembly Instructions

18

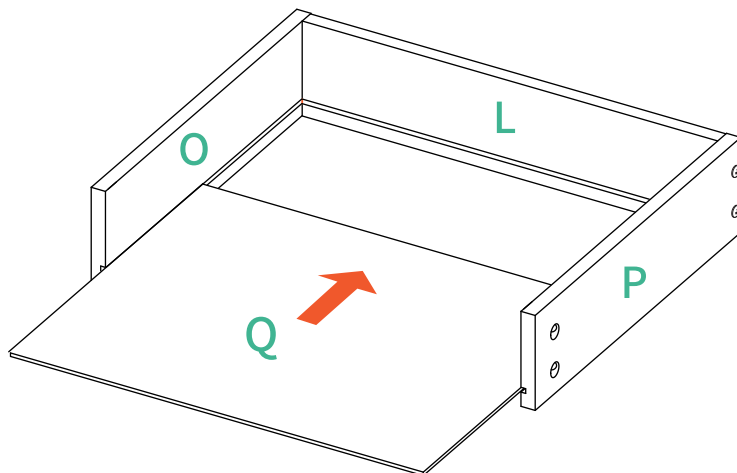
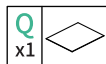

19

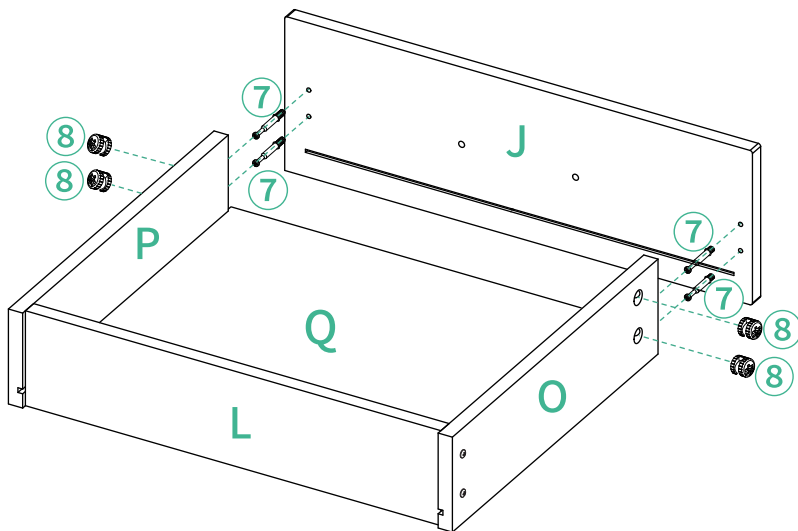
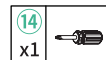
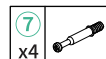
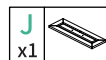

# Assembly Instructions

20

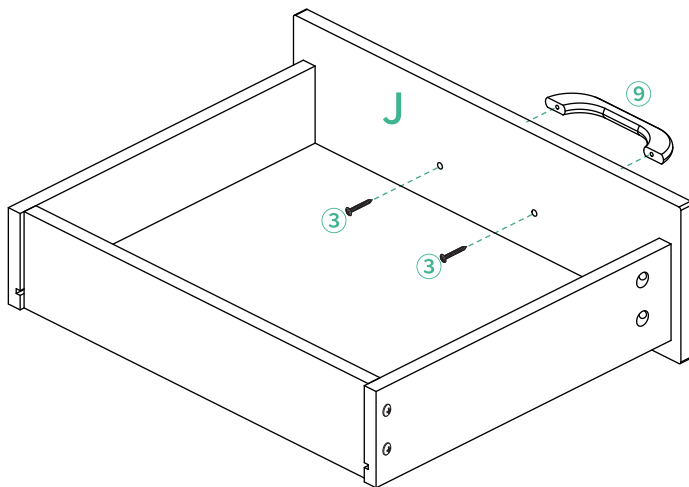
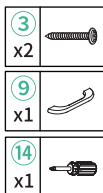

21

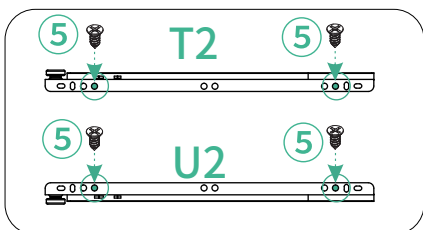
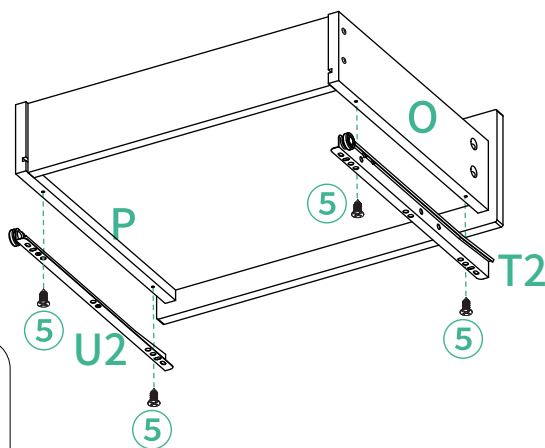
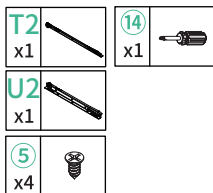

# Assembly Instructions

22

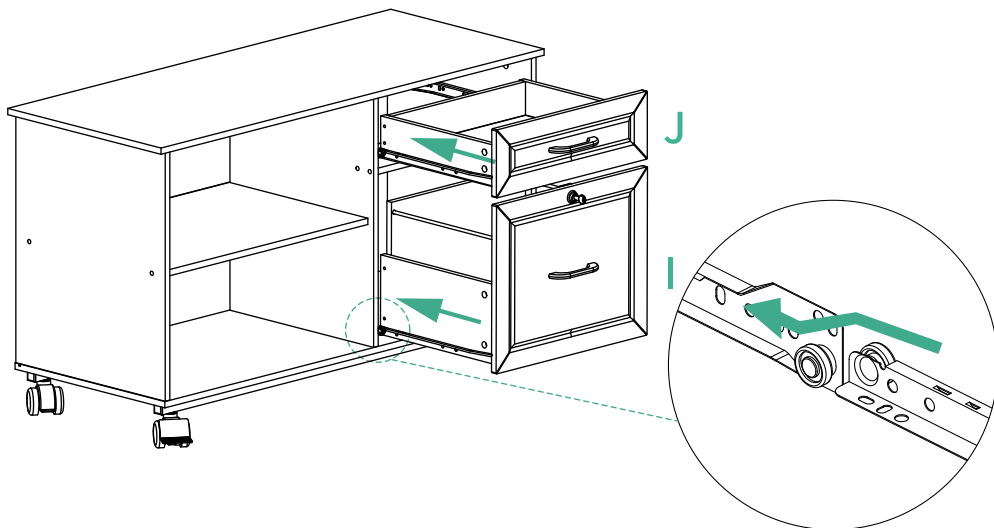

23

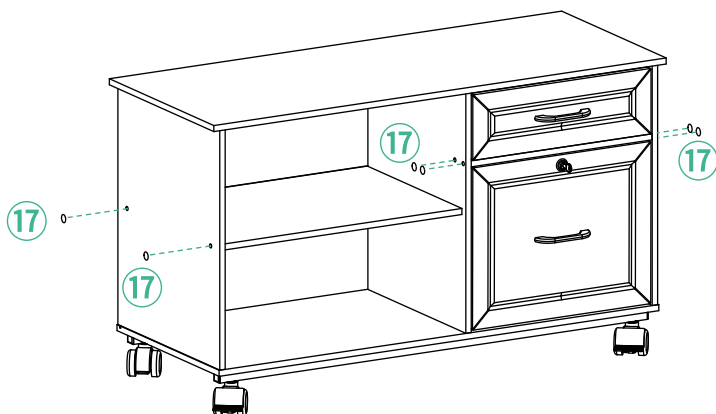
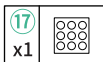

# Assembly Instructions

24

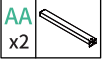

Note: Before installing the table legs, please check whether the height of the two legs is the same, if not, please press the table legs as shown in the picture to make their height consistent, otherwise it may affect the product lifting function.

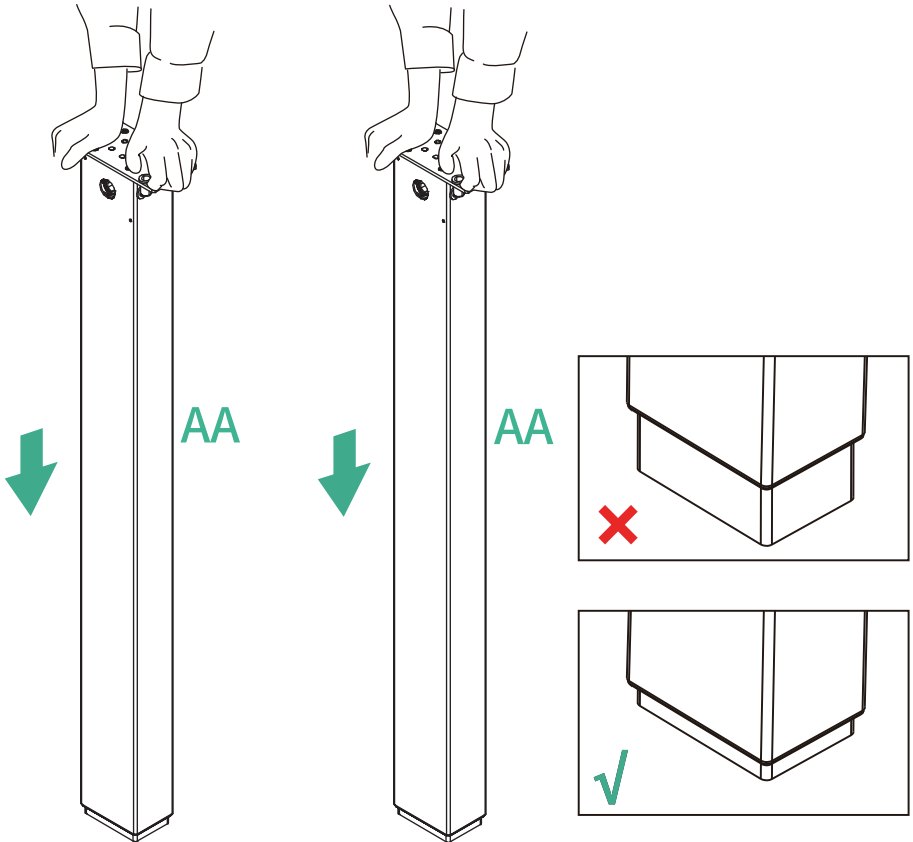

# Assembly Instructions

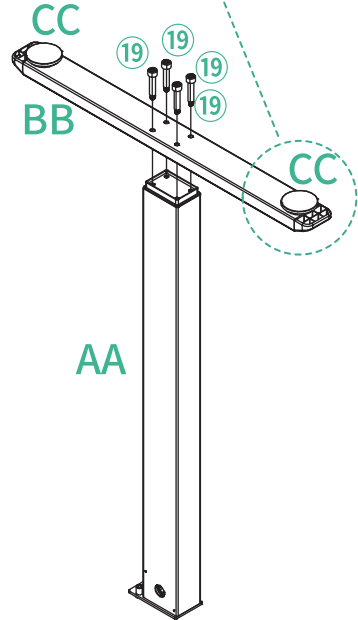
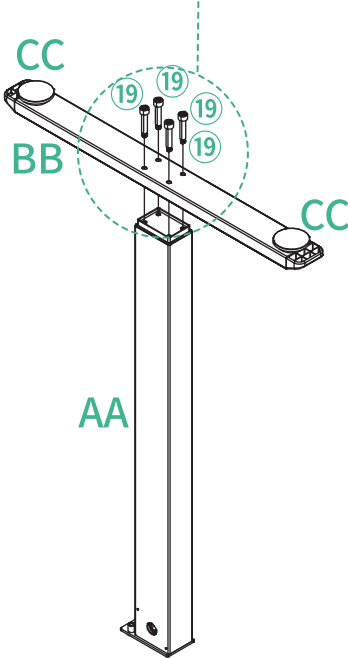
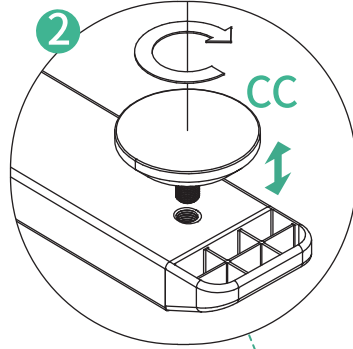
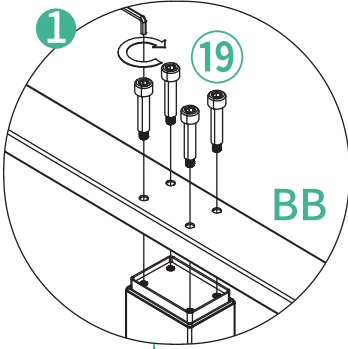

25

- BB x2
- CC x4
- 19 x8
- 28 x1



# Assembly Instructions

26

DD	
x1	
EE	
x1	

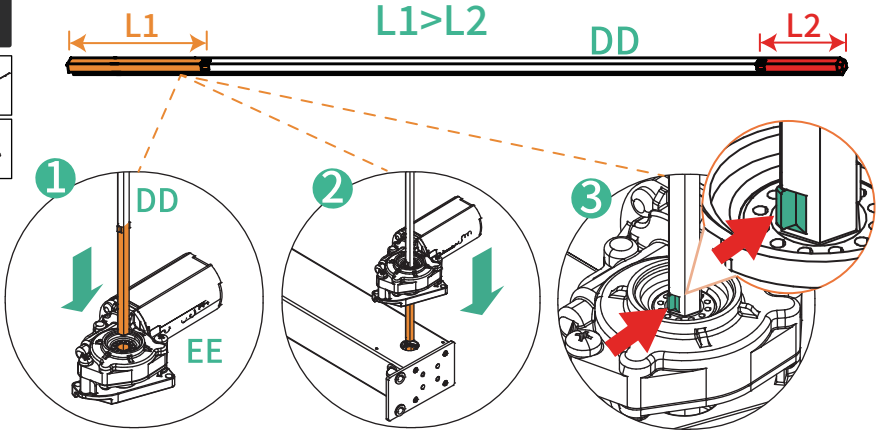

Insert the end of the part DD with the bump farther away from the motor EE.

The bumps indicated by the arrows on the part DD shall be installed in place.

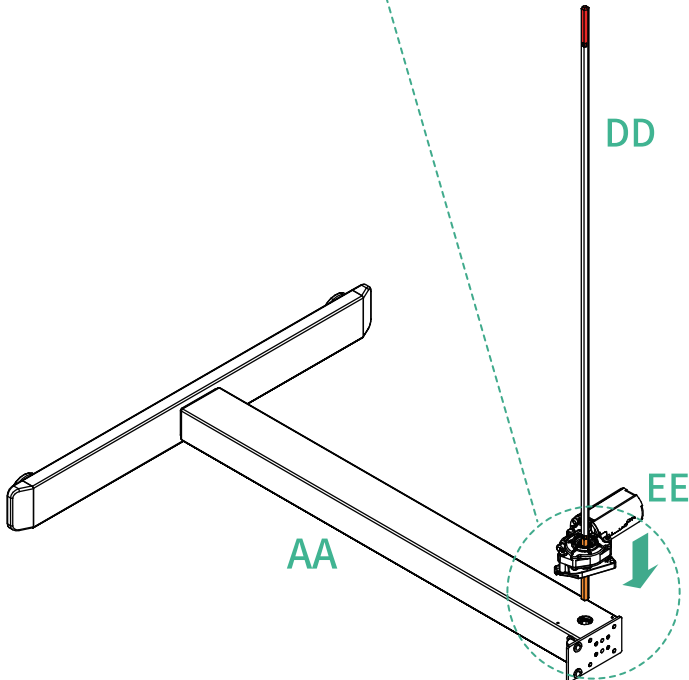

27

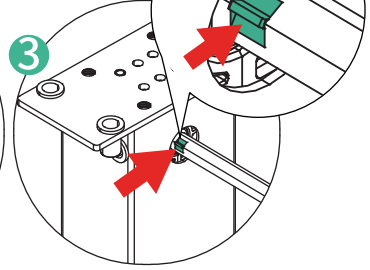
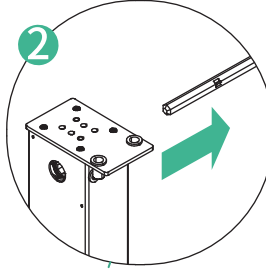
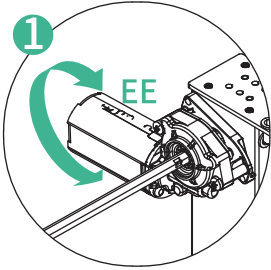

Please note: If part DD cannot be inserted into leg AA, turn motor EE slightly to insert it smoothly.

The bumps indicated by the arrows on the part DD shall be installed in place.

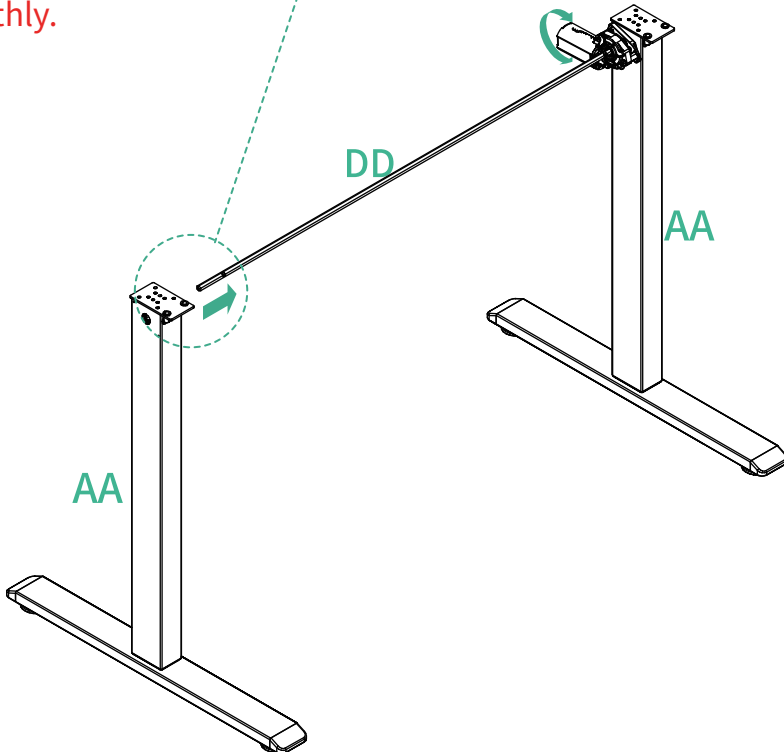

# Assembly Instructions

28

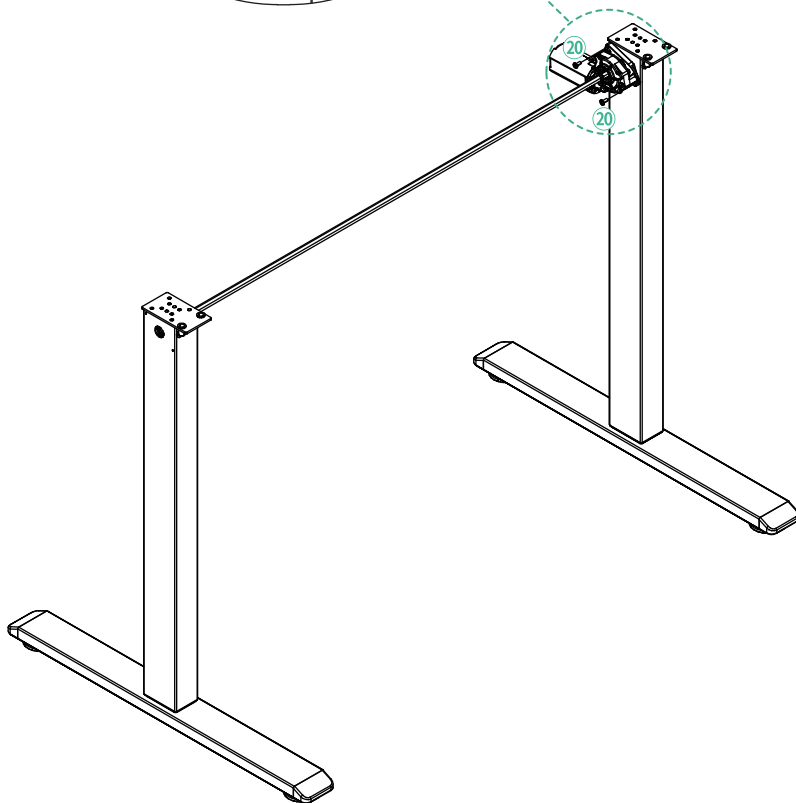
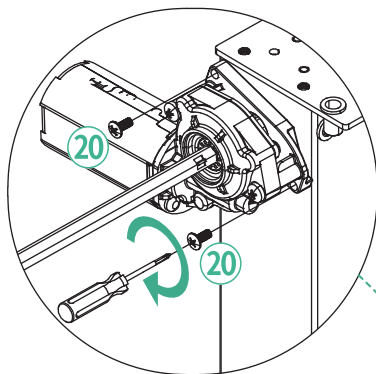
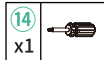

# Assembly Instructions

29

FF	
x1	
23	
x4	
28	
x1	

Please note: Keep the large holes in the part FF facing outward, otherwise the installation will result in failure.

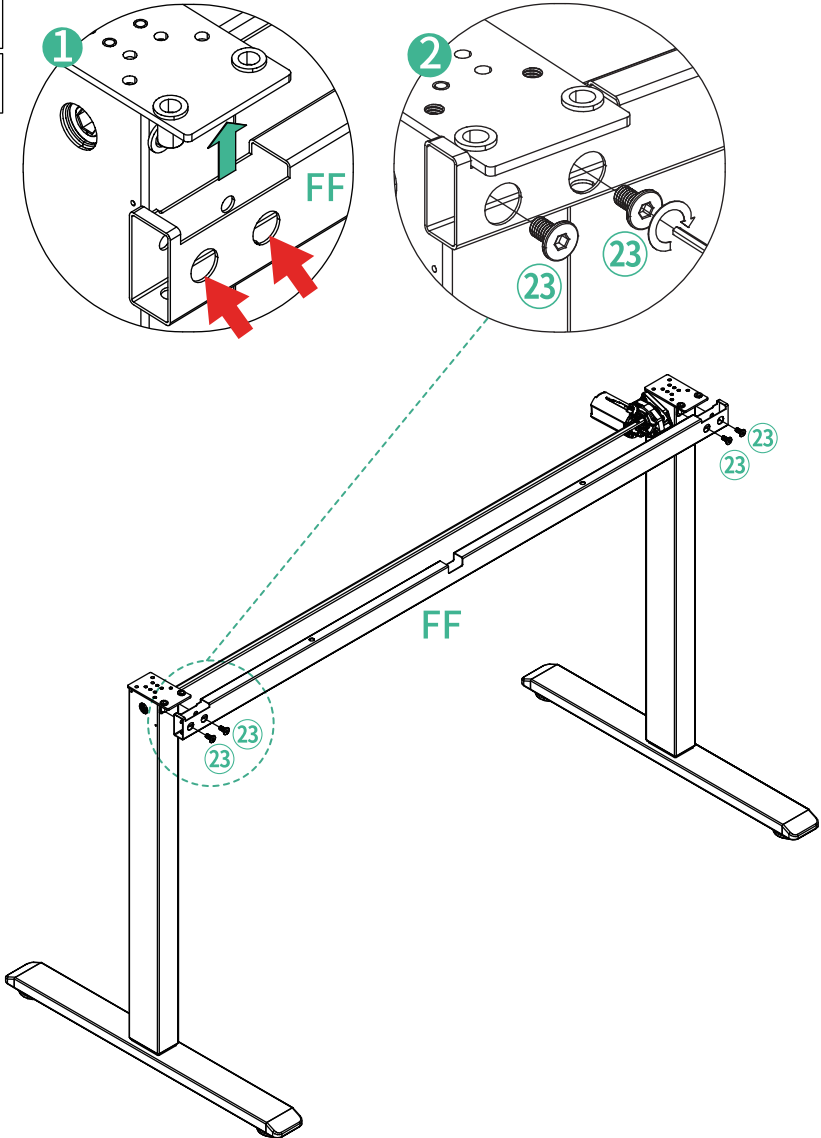

# Assembly Instructions

30



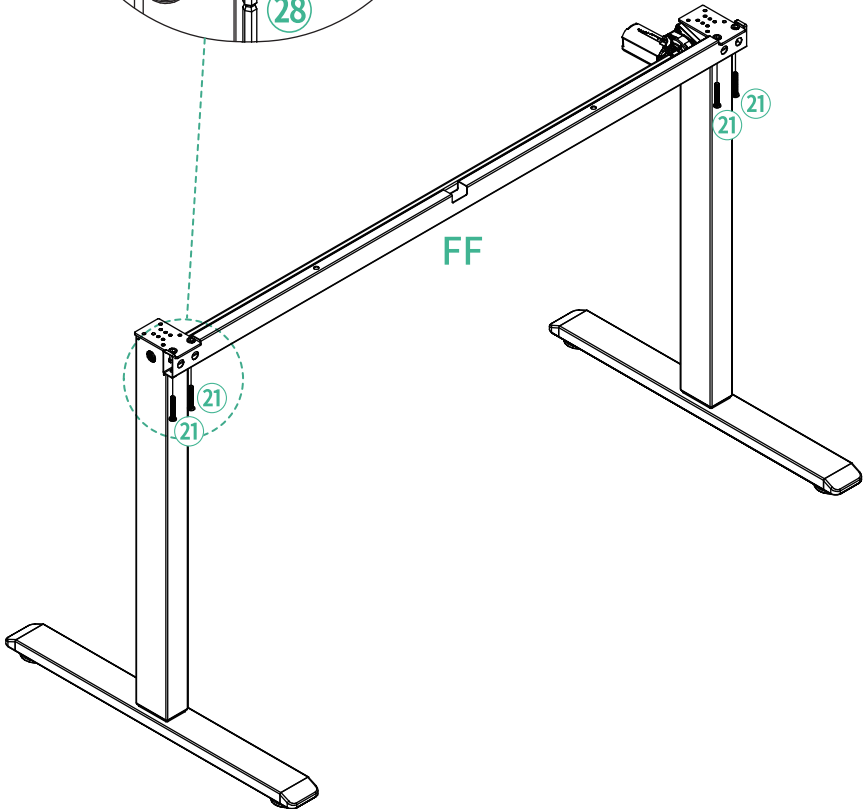
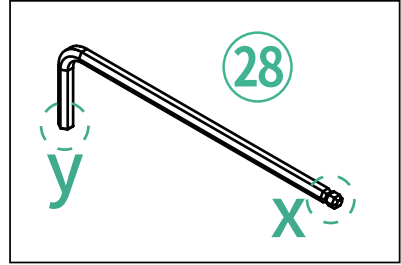
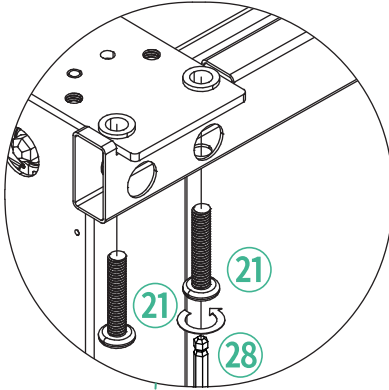

Please note: For easier installation, you can use the x end of the 28 wrench to tighten the screws 21 first, and then use the y end of the 28 wrench to tighten the screws 21.



# Assembly Instructions

31

GG	
x2	
23	
x4	
28	
x1	

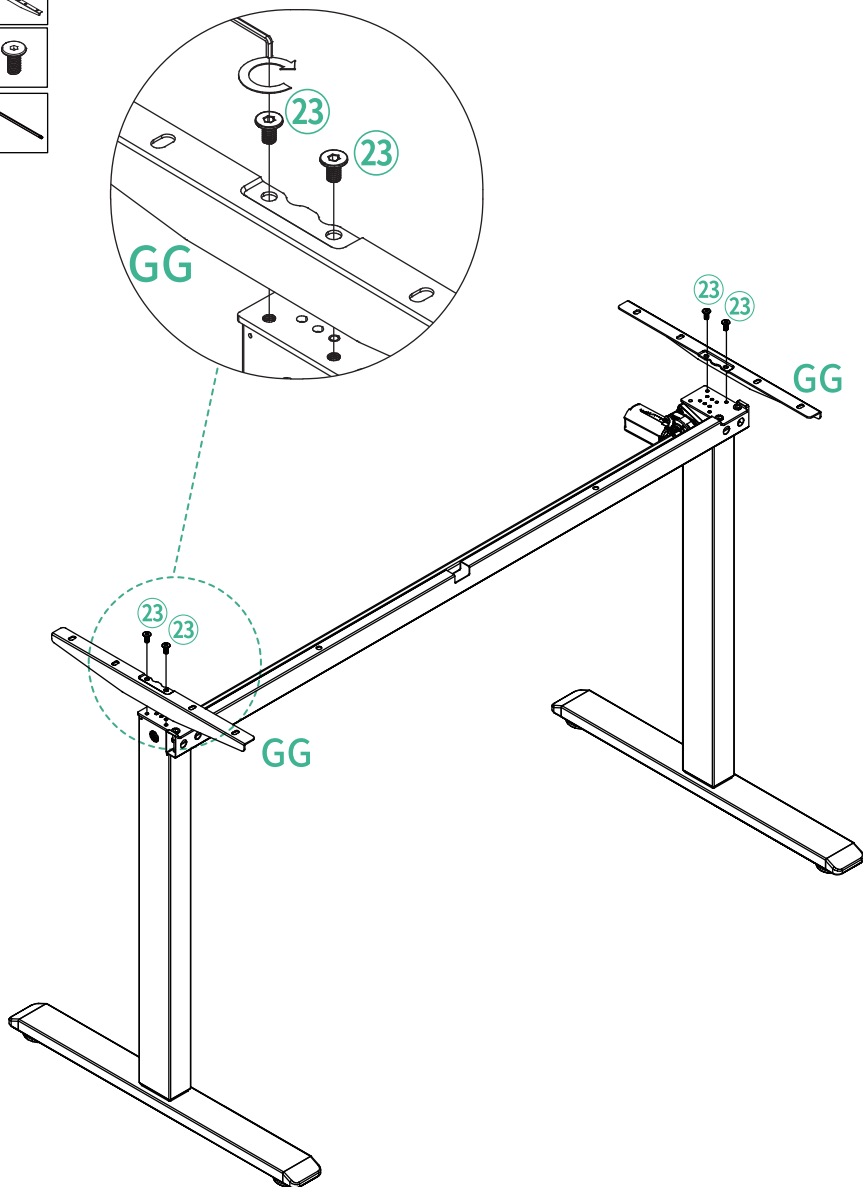

# Assembly Instructions

32

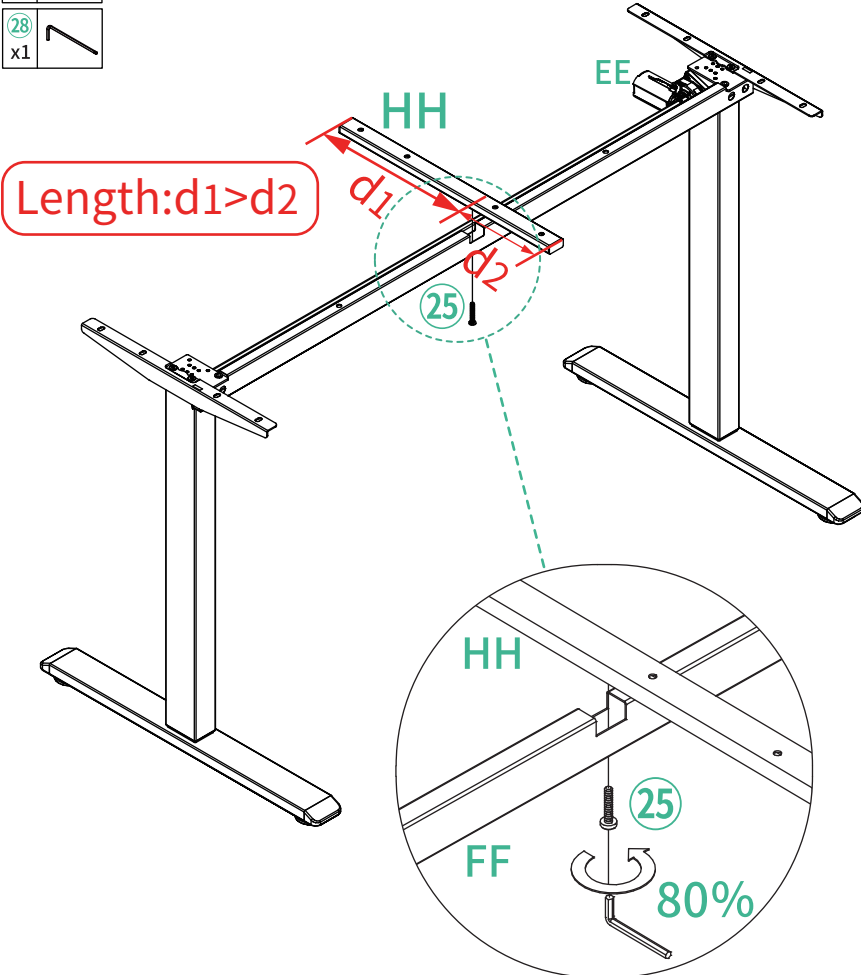

Please note: d1 of part HH needs to remain on the same side as motor EE.



For later easier installation, the screw 25 need to be tightened only 80% locked.

# Assembly Instructions

33

KK	
x1	
LL	
x1	
26	
x5	

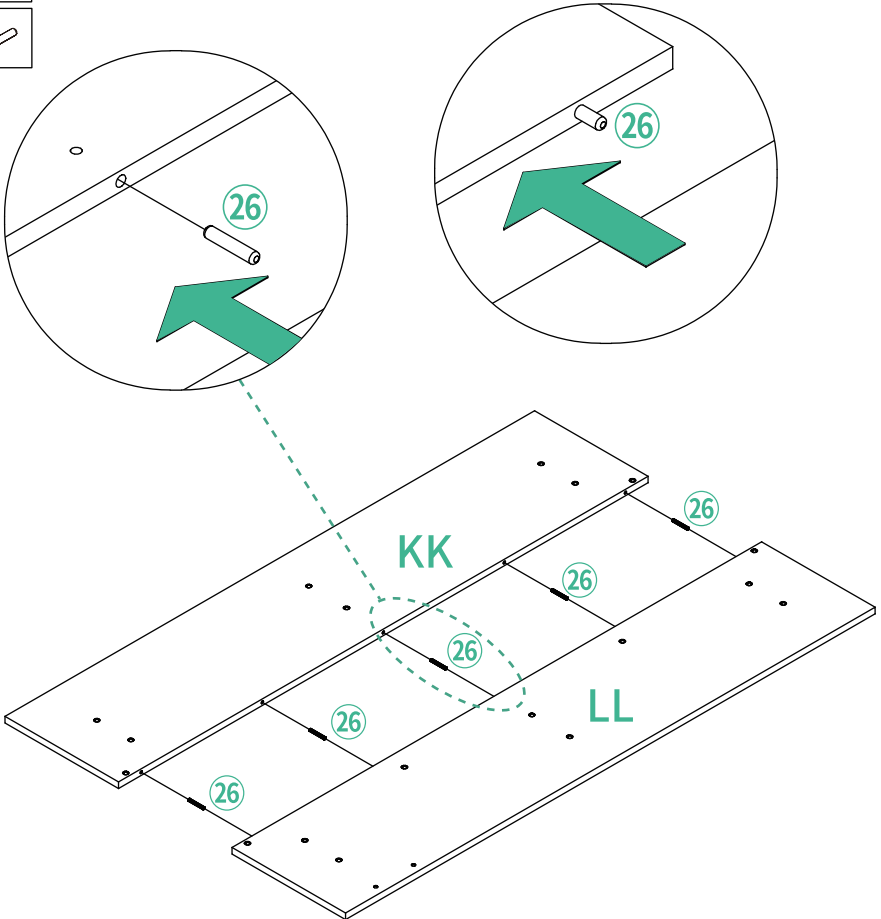

# Assembly Instructions

34

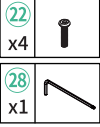

Install the motor EE on the side near the hand control mounting holes. Otherwise, the controller will not be installed.

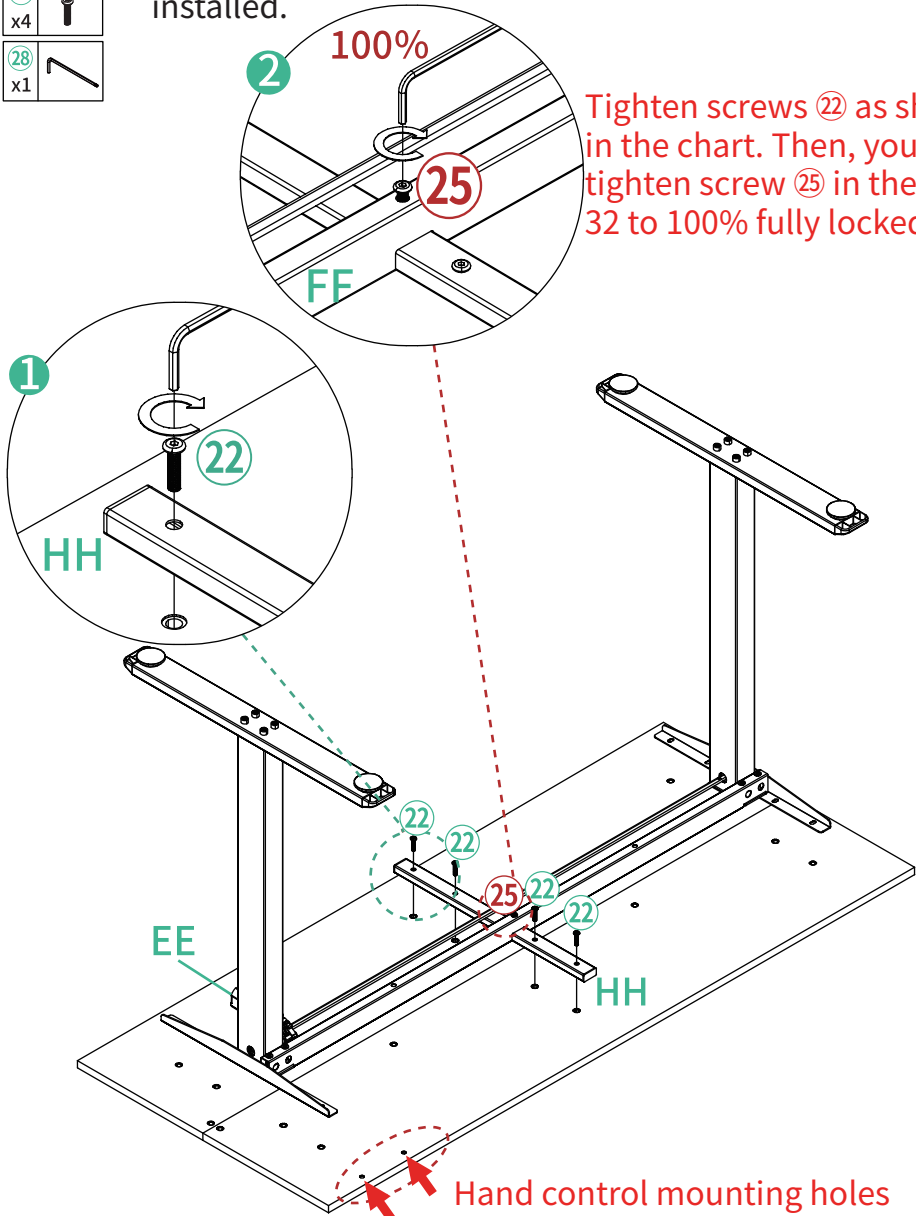

Tighten screws 22 as shown in the chart. Then, you can tighten screw 25 in the step 32 to 100% fully locked.

# Assembly Instructions

35

For later easier installation, the screws ②④ need to be tightened only 80% locked.

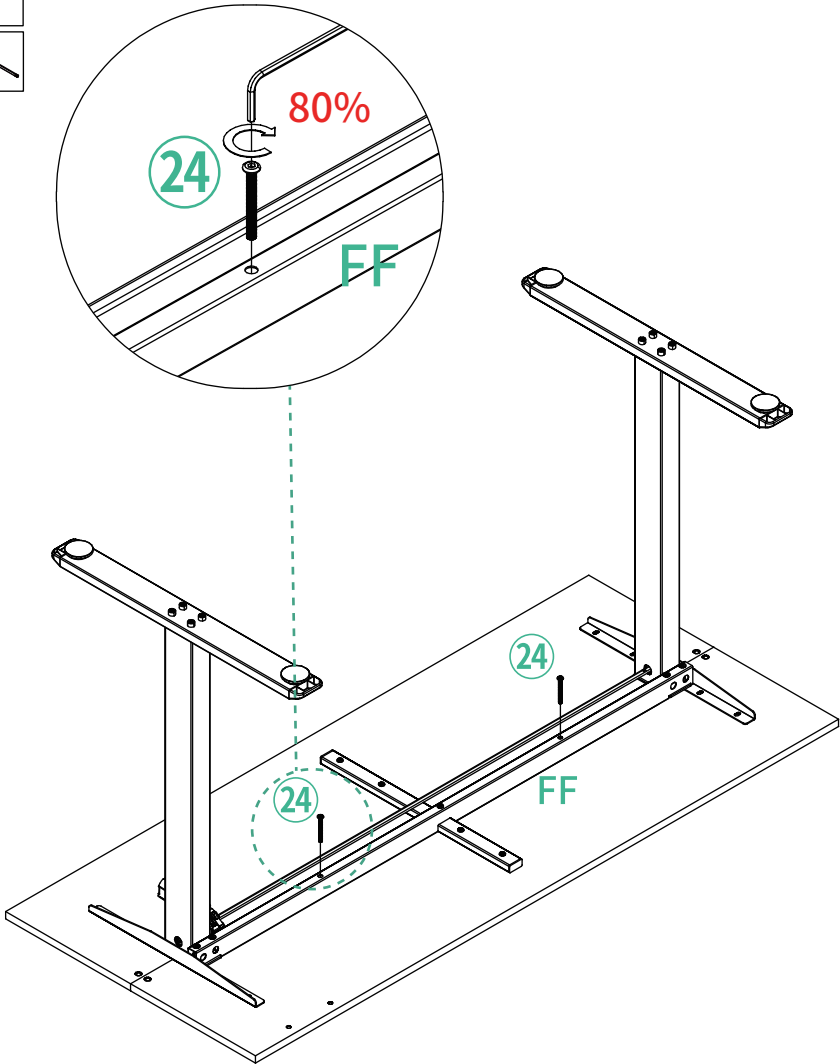
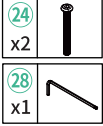



# Assembly Instructions

37

- II x1 
- 20 x2 
- 14 x1 

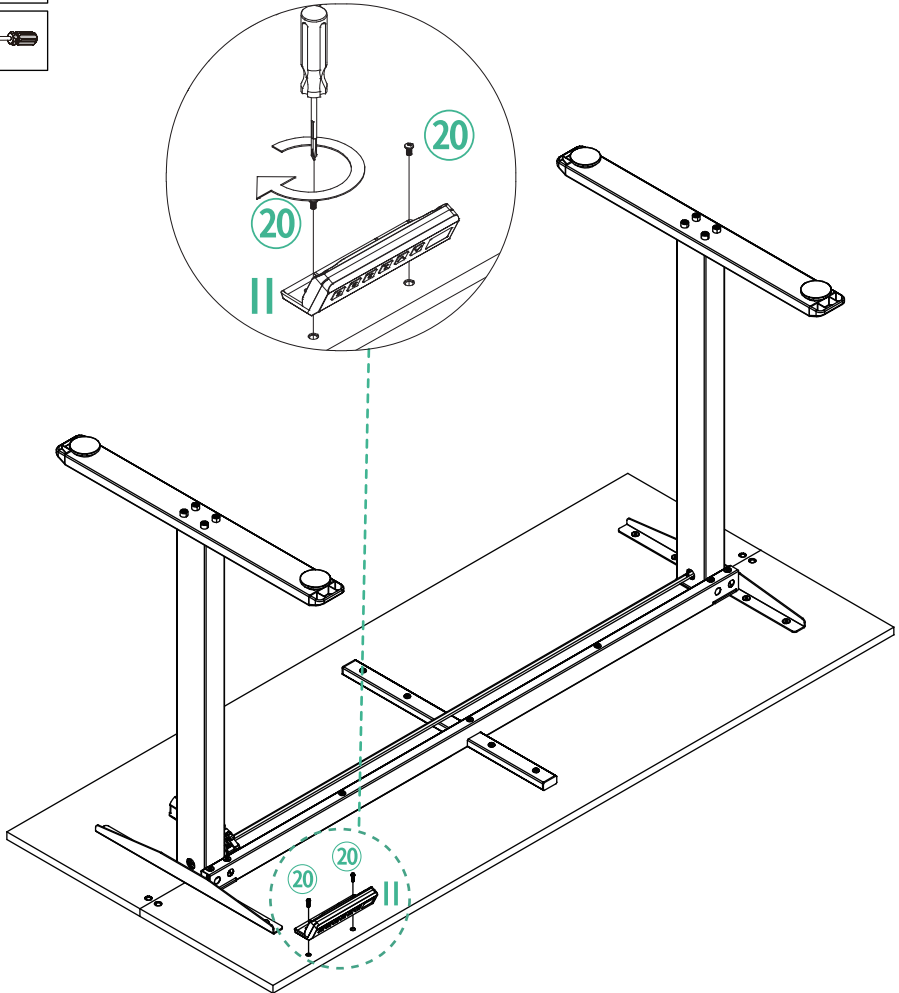

# Assembly Instructions

38

- 23 x4
- 28 x1
- 29 x2

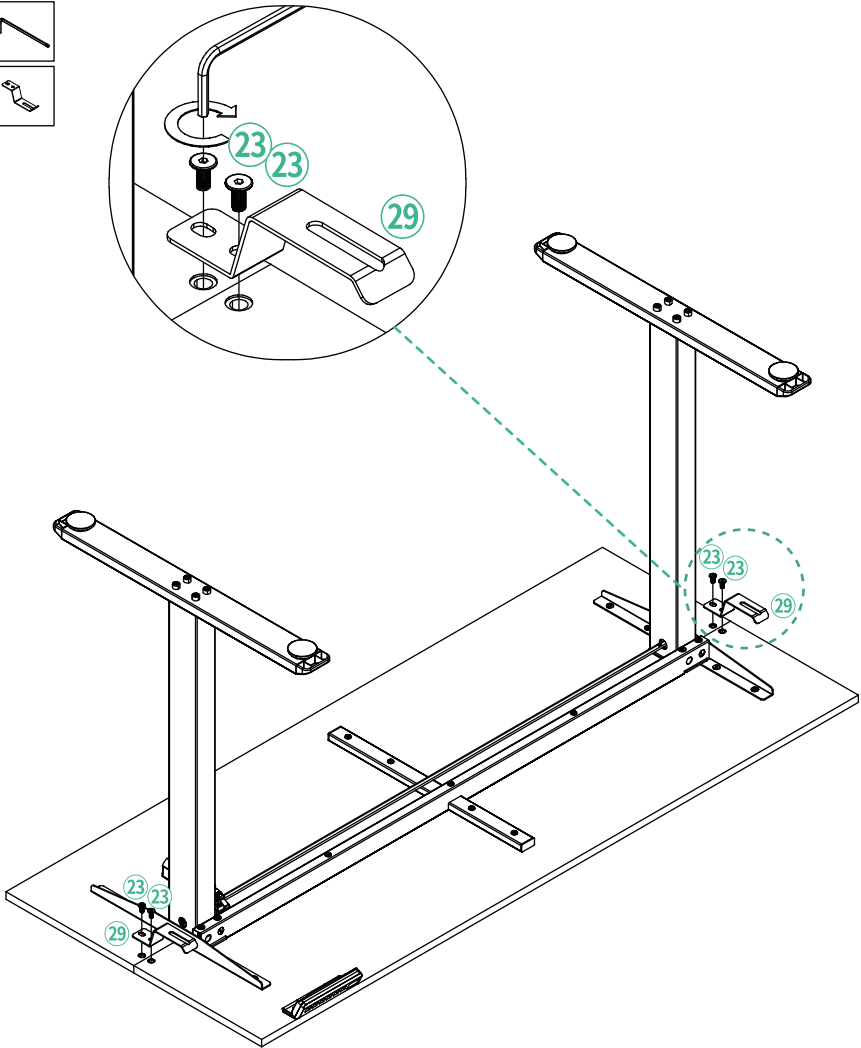

# Assembly Instructions

39

Fix the power cord with ties.

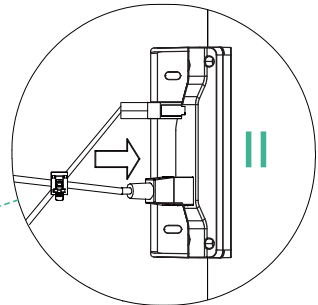
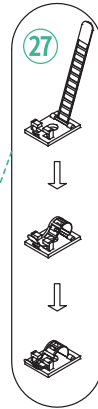
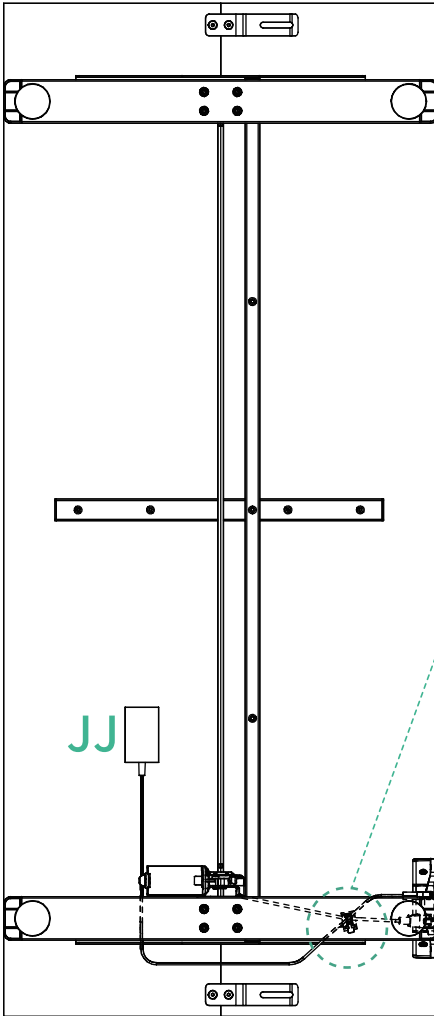
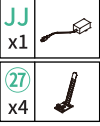

40

Tip: After completing the installation, please keep pressing and holding the controller “” key until the screen shows “FES” then release the button; this operation can make the product maintain the best state.

Please note: Do not operate other keys during the reset process to prevent the reset operation from failing.

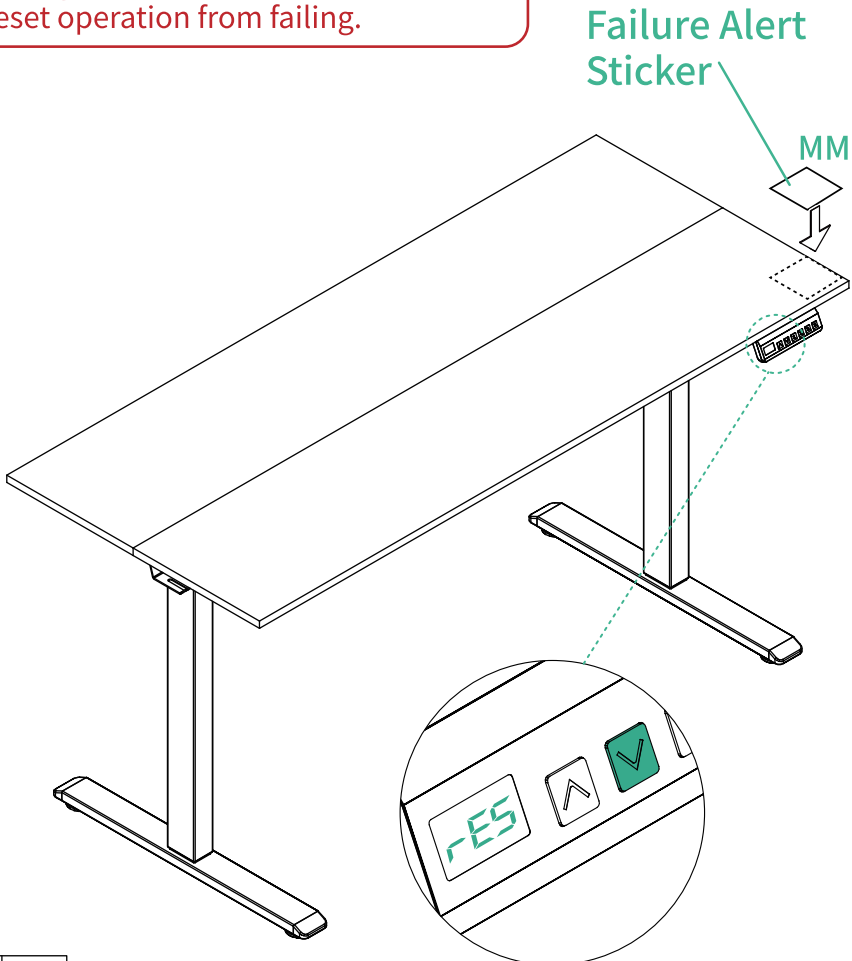

41

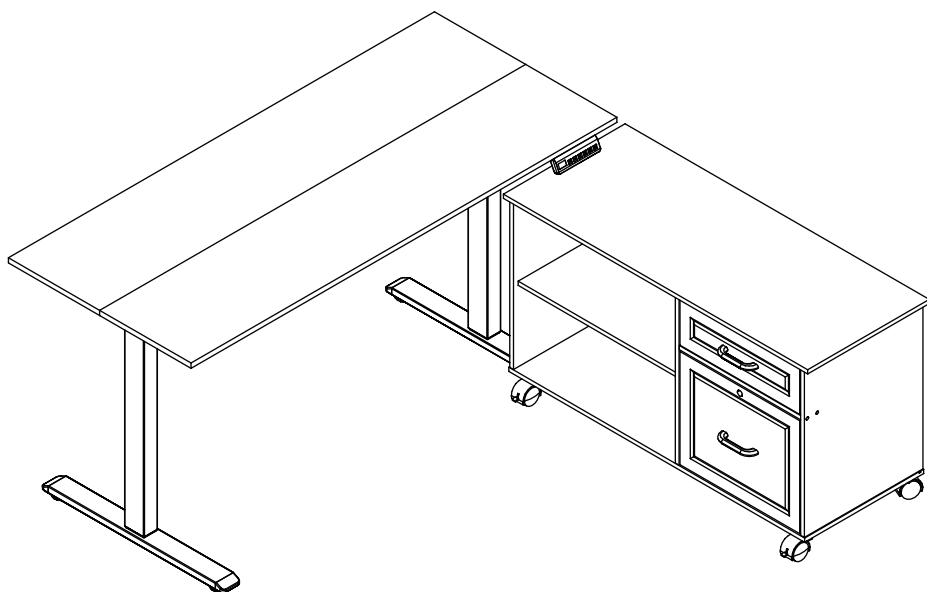

## Controller Instruction

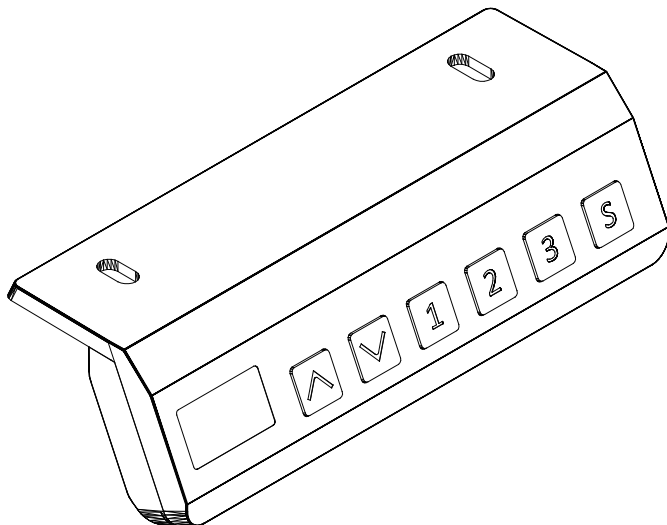

## Display Instructions

Key name	Description	Press duration	Operation process
⬆	Raise the desktop	Long press	Press and hold the ⬆ key to raise the desktop and enable the LED screen to display the real-time height value, and release it to stop the height adjustment.
⬇	Lower the desktop	Long press	Press and hold the ⬇ key to lower the desktop and enable the LED screen to display the real-time height value, and release it to stop the height adjustment.
① ② ③ S	Set the memory heights	Press the S key once	Press the S key once and the height value starts flashing. At this time, press the ①, ② or ③ key to save the current height to the corresponding position.
① ② ③	Move to the memory height / To use memory heights	Press the numeral key once	Press the numeral key to enable the height adjustable desk to automatically move to the corresponding preset height.

## Parameter Setting

1. After holding down the  $\text{S}$  key for 3 seconds, the digital tube displays "S--" and begins to blink;

2. Press the  $\text{S}$  key again to enter the setting mode, and display the function name.

The functions that can set parameters are as follows:

- Display unit of table height: Unit (U<sub>n</sub>)
- Strength of collision protection: Collision Force (CF)

Function of each key in setting mode:

- ① Return key to return to the upper-level menu.
  - ⊕ ⊖ Option switching.
  - Ⓢ Confirm key (Confirm to enter the next level menu of the current interface or confirm to select the current parameter).
- If you do not press any key within 20 seconds, exit the setting mode;

## Parameter Setting

Main menu interface	Submenu interface	Description
U <sub>n</sub>	SI SI Metric	After entering, the height unit value set last time is displayed. You can flip In the options (SI, In) with ⊕ and ⊖ keys. After selecting the option, press Ⓢ key to save the current option value, and keep the current option displayed for 2 seconds, exit the setting mode.
	IN Inch	
CF	OFF Off	After entering, display the impact force gear set last time, use ⊕ and ⊖ keys to flip in the options (Off, L, N, H), press the Ⓢ key to save the current option value, and keep the current option displayed for 2s, exit the setting mode.
	L Light	
	N Normal	
	H Heavy	

### ANNOTATION:

- ① There may be an error of up to 10mm between the value on the display and the actual height value, which is within the normal range;
- ② The display will be automatically extinguished if no key is pressed for a long time. At this time, you can press any key to turn on the display.

1. Power supply: AC100V-240V,50/60HZ.
2. Service Environment: temperature 0-40C. Keep products away from corrosive gas, liquid and dusty objects. Outdoor use is prohibited.
3. Keep children and animals away from the tabletop during use, and make sure the tabletop does not touch any walls.  
Remove obstacles that are above 65 centimeters under the desk.
4. Never operate system in damp environments or if any electrical components have made contact with liquids.
5. Unplug the power plug before cleaning, wipe the dust on surface with slight wet dishcloth when cleaning, be careful not to let the drops into the internal parts, not loosen the connector.
6. Slight noise caused by the V-ribbed belt or brake system due to structure will not have any effect on the use of the equipment.
7. Please make sure there is no hazard sources in your operating environment. e.g., do not litter the tools around.
8. This product is designed with a duty cycle of Max. 25%. (Max. 5 min. ON, 15 min. OFF.)
9. During daily maintenance, use a clean soft cloth to remove surface dust. Do not use a wet cloth or hard material to wipe the surface of the table.
10. Avoid contacting the surface with acid-based chemicals.
11. To smooth out slight scratches, gently wipe with a soft cloth.
12. Avoid attaching tape directly to the outer surface of the metal feet to prevent paint from peeling.



## Customer Service



### **30 DAY Return Policy**

If you're not completely satisfied with your purchase, please return the merchandise via our Official Customer Support.

Unused merchandise can be refunded or exchanged within 30 days of purchase.



### **1-Year Warranty**

We guarantee your product is free from defects in product material and workmanship for one (1) year starting from the date of purchase during normal use of household conditions. If your appliance fails to operate properly within our warranty period, we will arrange a new one.

Replacement is free and all shipping costs are covered.



### **Quick Response within 24 Hours**

If you are still unable to resolve the issue you are experiencing, please contact us immediately via our support email. It doesn't matter if the product has been installed or not, our customer support team will respond within 24 hours and assist you quickly and efficiently. The most efficient way to confirm your problem to us is to attach a video, which illustrates your product issues.