

IX. Fault elimination:

Fault	Fault cause	Solution
No sound from louds peaker	1. The volume is adjusted too low. 2. The adapter of loudspeaker has been loosened. 3. The loudspeaker is damaged.	1. Increase the volume 2. Reconnect the wire properly 3. Replace the loudspeaker
Failure of remote control	The remote control has low battery.	Replace the battery
The machine cannot be activated	1. The creepage protection plug has not been electrified. 2. The control line between controller and electric box has not been connected properly.	1. Check if creepage protection plug indicating lamp has been extinguished. If the answer is yes, reconnect the power supply. 2. Reconnect the computer line properly
Underwater lamp does not light up	1. The wiring for underwater lamp is loosen; 2. The bulb is damaged.	1. Reconnect the wire properly; 2. Replace with new bulb.
Poor radio result	1. The antenna has not pulled out; 2. The radio frequency has not been adjusted properly; 3. The user is in weak signal area.	1. Pull out the antenna and place properly; 2. Readjust radio frequency properly; 3. It is influenced by geographical position.

X. ITEMS FOR ATTENTION:

1. The system must be erected by qualified technical personnel and the creepage protection switch plug shall be mounted in a place of easy control.
2. It must be connected firmly during erection. In the case of loss due to improper earthing, the manufacturer will not assume any responsibility.
3. The motor must be erected flatly and stably and the shell shall be firmly earthed.
4. The whole set is usually under standby state. If it is not used for long time, please pull off the master power switch.
5. During erection, it is required to consider load capacity of power supply circuit, otherwise it may influence the normal working of the system or cause accident.
6. During erection, all the electric appliances and electric parts shall be provided with moisture resistant measures.

COMPUTER MASSAGE BATHTUB CONTROLLER

Carry Out GB4706.1-1998
Standard: GB4706.48-2000
GB5296.2-1999

USER MANUAL

(MODEL: GD-7001)

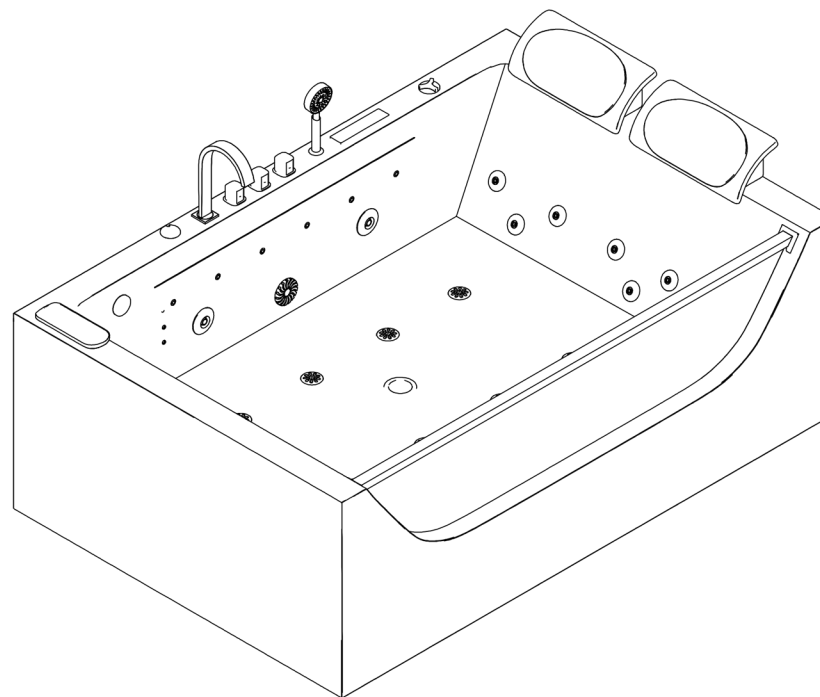

● Before you are going to use it, please read this user manual carefully

I、PRODUCTS FUNCTION:







Thanks for your choosing and buying the Products. Before you are going to use it, please read this user manual carefully, It can tell you how to use and it. Then you can use all functions. It has many functions.

- 1、 Highly sensitive water level sensor
- 2、 Bubble bath massage function
- 3、 Surfing function
- 4、 FM Digital Turing Radio and Double Power Amplifier
- 5、 Ozone sterilization function (SELECTABLE)
- 6、 Expand audio input function
- 7、 Underwater lamp function
- 8、 Almighty remote controller
- 9、 Touch Technology function
- 10、 Exterior heating apparatus function(SELECTABLE)

II、 SPECIFICATIONS

- | | |
|--|-----------------------------------|
| 1、 Power supply: AC220-240V 50-60Hz | 8、 Dielectric strength:1500v,1min |
| 2、 PUMP Load: ≤ 1000W AC220-240V | 9、 Lighting load:≤ 10W DC12V |
| 3、 Bubble bath pump Load: <750W AC220-240V | 10、 Music power: ≤10W 8Ω |
| 4、 S/N radio:>45dB | 11、 Frequency range:FM88-108MHz |
| 5、 Leak current: <0.25mA | 12、 Waterproof grade: IPX4 |
| 6、 Ozone Load: ≤8W DC12V(SELECTABLE) | |
| 7、 HEATER Power: ≤2000W AC220-240V(SELECTABLE) | |



2、 Radio section :

- (1) Pull out the radio antenna and place in "Y" form. When radio () key is pressed, the screen will appear radio frequency and the volume will rise from "0" to "15" DB with slight sound for loudspeaker.
- (2)SEARCH:Press the key () for more than 2 seconds,When the screen will display the "T U N " sign, Press () or () key for upward or downward frequency selection. Spot pressing is for manual selection. When the key is pressed for more than 2 seconds, the frequency will move upward or downward automatically until the broadcasting station is received. In the case of poor receiving environment or weak signal for receiving, it is recommended to select in manual selection mode.
- (3)MEMORY:After selecting the broadcasting station, press () key to display "M - - 0 1" to "M - - 20" ,Then it can be stored in this Number. The total memory for station is 20. If the received broadcasting station is not ideal, please pull out antenna and adjust the direction of antenna.
- (4)Repeated hearing:Press the () key for selection of the position of desired station, the screen will display the Number "C H 0 1 - - C H 2 0" thus you can hear the voice.



Search and Memory procedure:Press () more than 2 seconds ➔

Press() or () When displays " T U N " ➔ Press()

Repeated hearing procedure: Press () key for what you need

- (5) Volume adjustment --- The volume can be adjusted by pressing () or () key and the screen will display corresponding volume DB number.

3、 Enter AUX FUNTION:

Connect the Exterior audio wire with the external Faucet of the main control box, Press () key to the position of AUX, then choose the suitable volume by pressing () or () to listen.

- 4、 **Power-off:** Pressing of () key can switch off all the functions while display screen set will be in standby state. In case that it is not used for long time, please pull off the master power switch.

(2) Surfing function:

Firstly, fill water into the bathtub. When the indicating sign (☒) goes out, it has reached standard level. You can press surfing key (🏄) on the panel for starting of surfing pump while a dynamic surfing sign will also appear on the screen accordingly. You can switch off the surfing function by pressing surfing key (🏄) on the panel. Then the surfing pump will stop running and the surfing sign on the screen will disappear. **【Note: A、 When the water in the bathtub Does not reach the standard level, the surfing pump will not start; only static sign (⤴) and flashing water shortage sign (☒) appear on the screen. Then you need to fill water into the bathtub. B、 When the surfing pump is activated for 60 minutes, it will switch off the function automatically.】**

(3) Function of heater(SELECTABLE):

Only after starting the surfing pump can start the heating function effectively by pressing heating key (🔥) more than 2 seconds. The heating sign (HEAT) will appear on the screen accordingly. If the sign is dynamic, it means that the working conditions of heater are satisfied and the system is under heating. If the sign is static, it means that the working conditions are not met and the heater will stop working.

【Note: When surfing pump is switched off, this function will also be deactivated.】

(4). **Bubble bath pump Function:** Press (🫧) key, the bubble bath pump is turned on, LCD display “🫧” sketch, press again (🫧) key to turn OFF.

(5). **Water light function:** Press (💡) key, the water light is turned on, LCD display “💡” sketch, press again (💡) key to turn OFF.

(6). **Ozone function(SELECTABLE):** Press (🏄) key for over 2 seconds, the ozone is turned on, LCD display “O₃” sketch, press again (🏄) key for over 2 seconds to OFF. (NOTICE: The working-time of the Ozonizer is 15 minutes. So the Ozonizer auto is turned off after 15 minutes)

III、SYSTEM INSTALL SKETCH

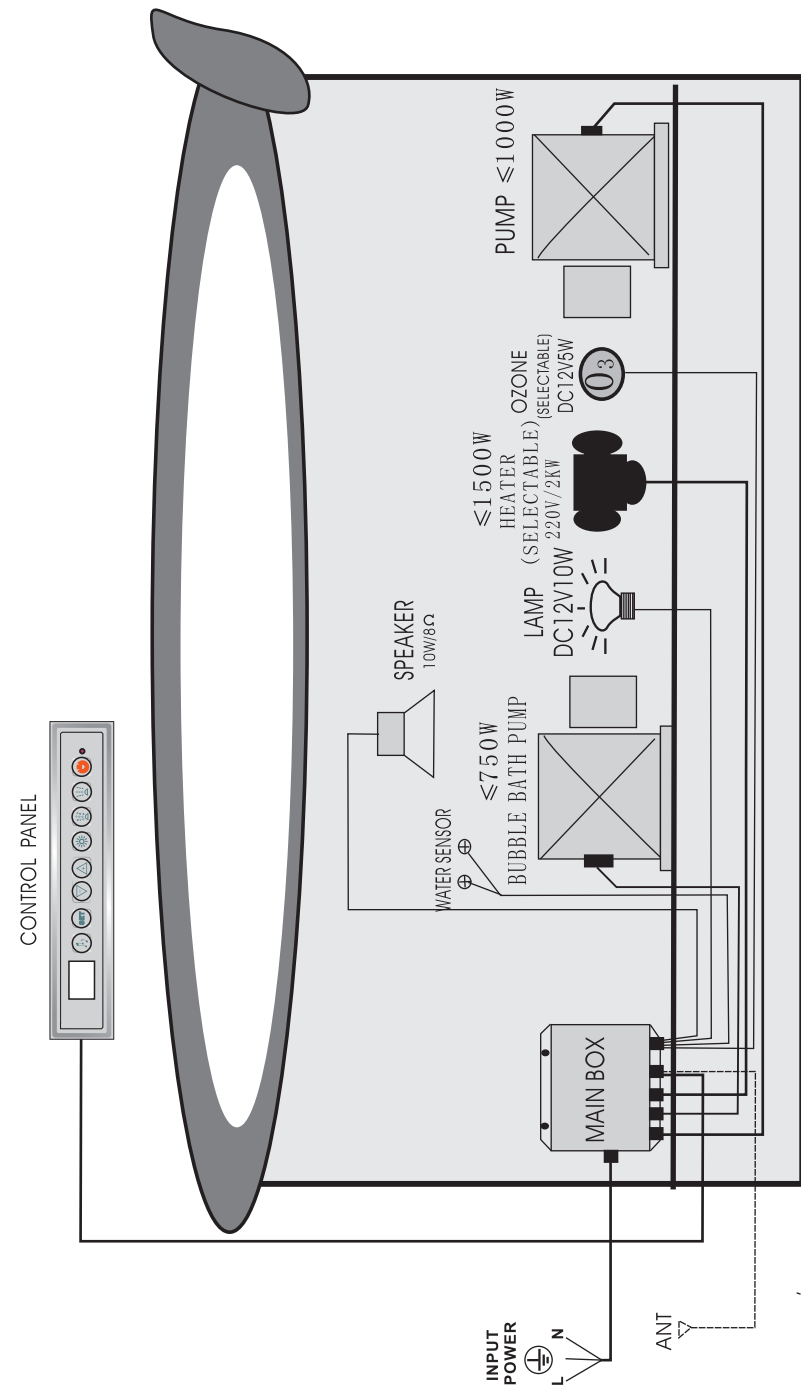

IV. THE MASSAGE BATHTUB CONTROL CONNECT SCHEMATICS

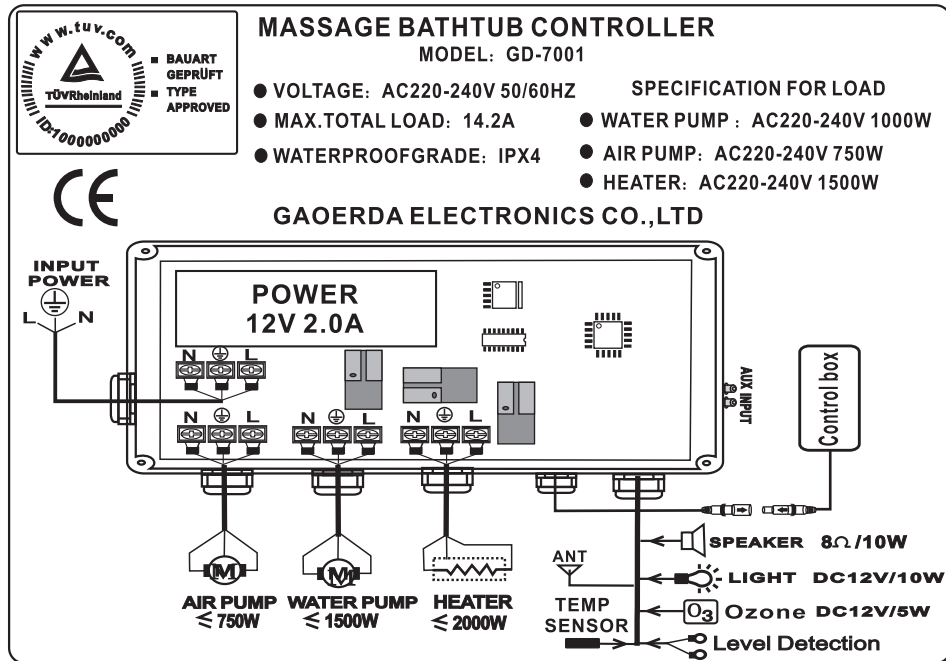

V. PANEL FUNCTION DESCRIPTION

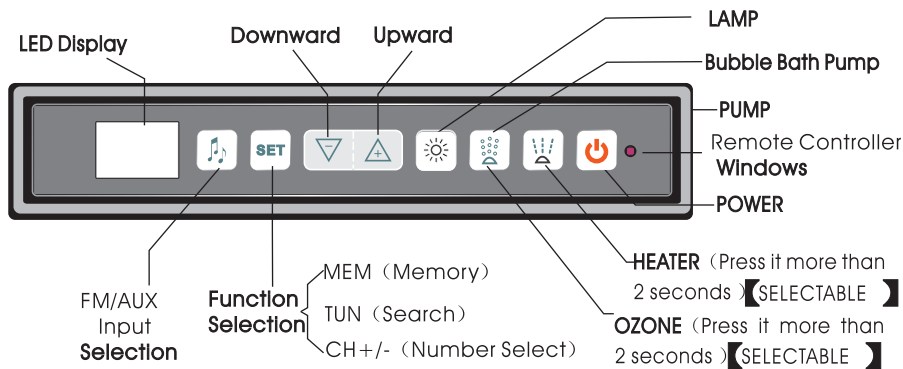

VI. SCHEMATIC DRAWING OF REMOTE CONTROL

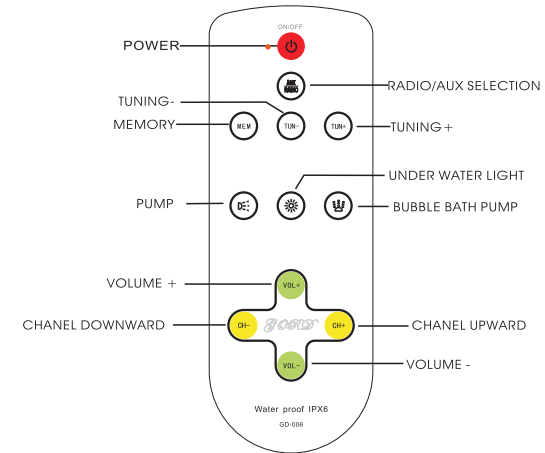

VII. OPERATION INSTRUCTION:

1. Surfing section:

(1) ON-OFF operation of the system:

After turning on the creepage switch, the system will be electrified and pressing of power key (⏻) will start the system. The display screen will appear (SPA), and display the temperature. By this time you can perform setting and operation of various functions according to the requirement of users.

Switching-off: The system can be directly switched off by pressing power key (⏻)



Model has not heating function:



Model has heating function(selecting): Length display Actual temperature, Flashing display set up temperature.

Model has heating function can set the Preferences temperature: press (▲) or (▼) to change the Preferences temperature, only in the status of (radio/AUX off). The Preferences temperature can be set between 30°C to 45°C, when the water temperature reach the Preferences temperature, the heater will come to the status of constant temperature.