

4

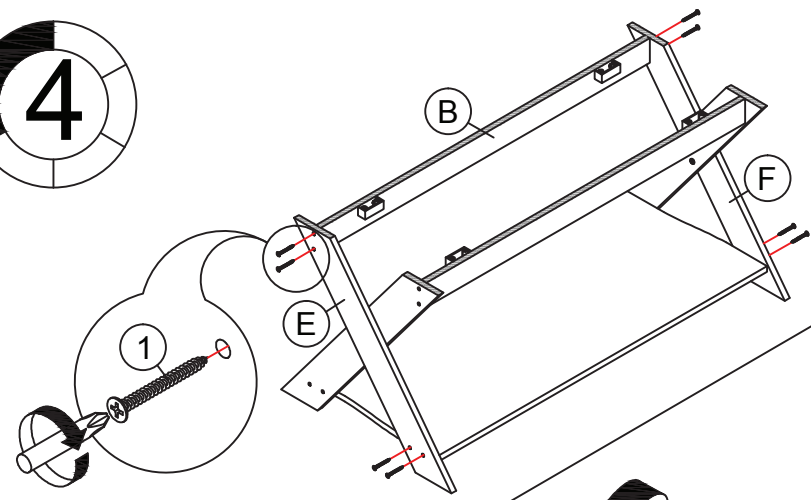

5

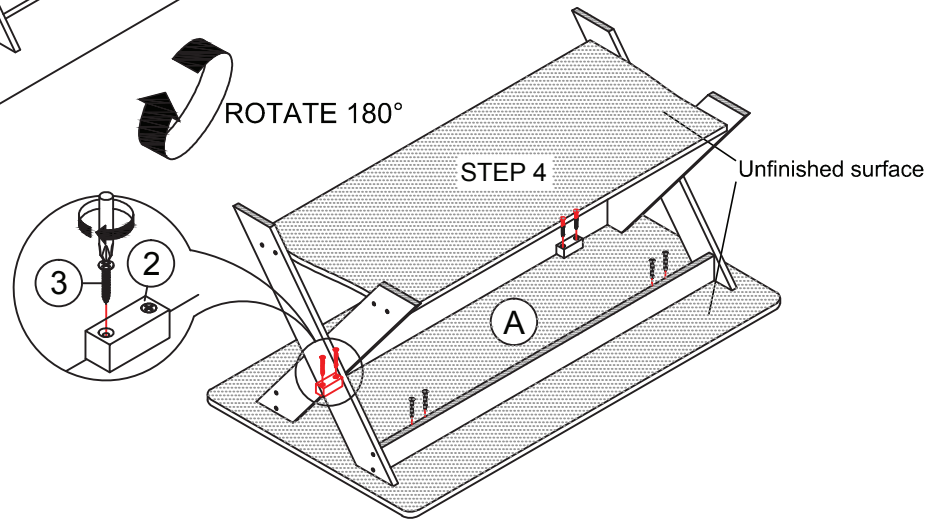

6

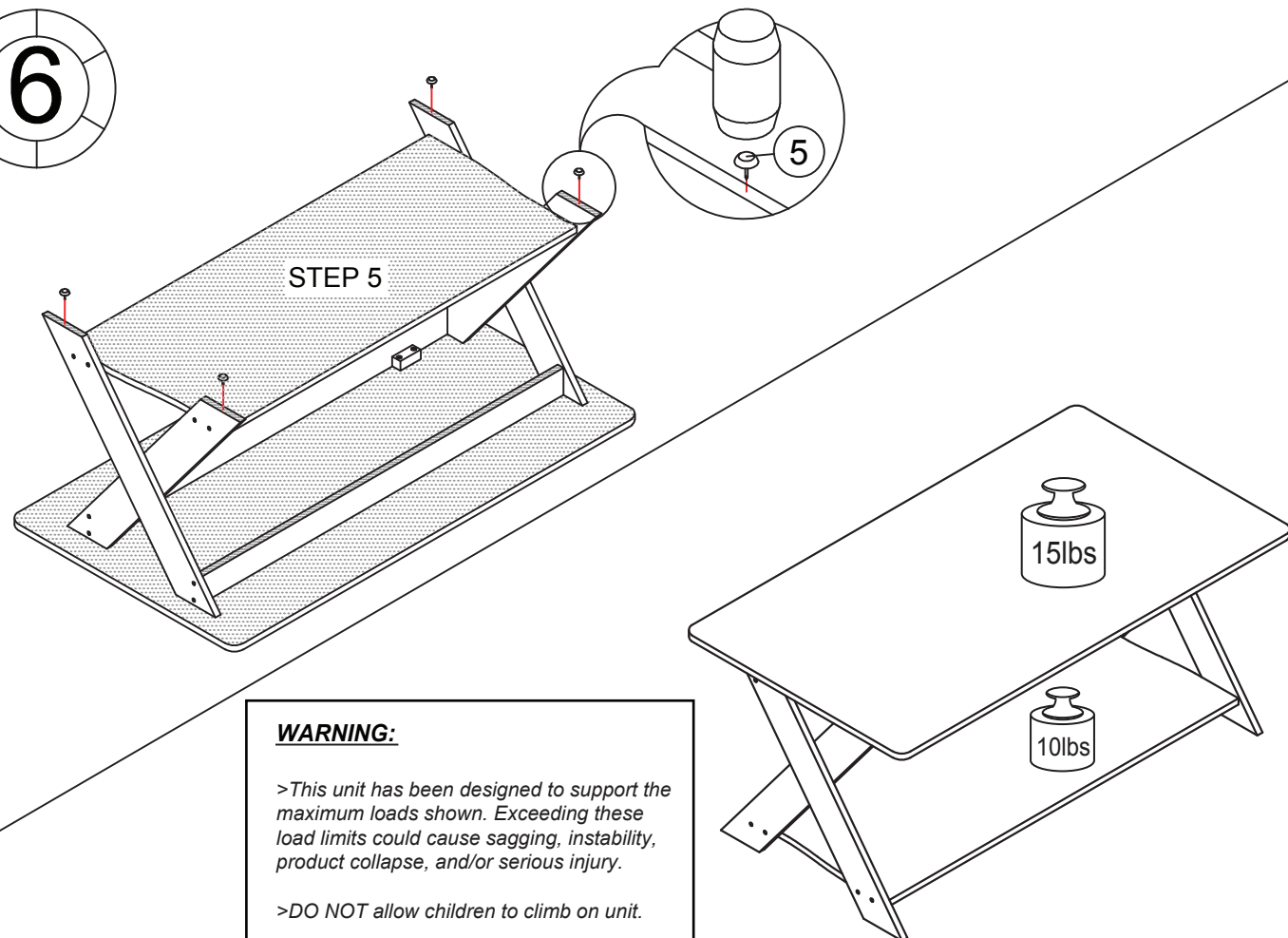

**WARNING:**

>This unit has been designed to support the maximum loads shown. Exceeding these load limits could cause sagging, instability, product collapse, and/or serious injury.

>DO NOT allow children to climb on unit.

# Assembly Instruction

Coffee Table

00:30

Approx. 30 minutes





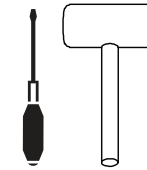



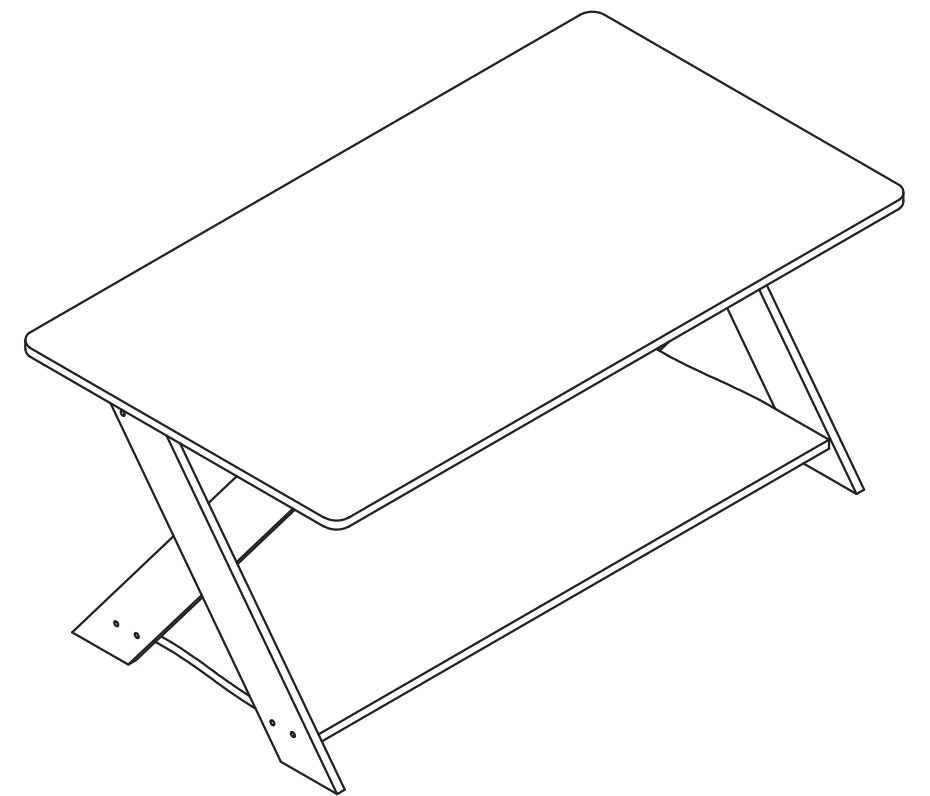

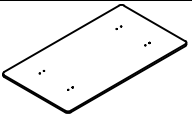
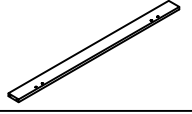
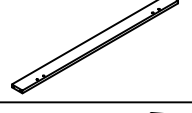
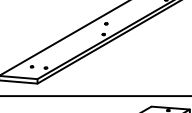
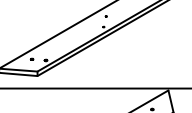
Recomm. 1 Person



Tools Required



NO	PARTS LIST	QTY
A	TOP PANEL 	1pc
B	LONG SUPPORT PANEL 	1pc
C	SHORT SUPPORT PANEL 	1pc
D	INNER SIDE PANEL 	2pcs
E	LEFT SIDE PANEL 	1pc
F	RIGHT SIDE PANEL 	1pc
G	BOTTOM PANEL 	1pc

NO	HARDWARE LIST	QTY
1	C/B SCREW A 	16pcs
2	BRACKET 	4pcs
3	C/B SCREW B 	8pcs
4	CENTER SCREW 	4pcs
5	NAIL LEG 	4pcs

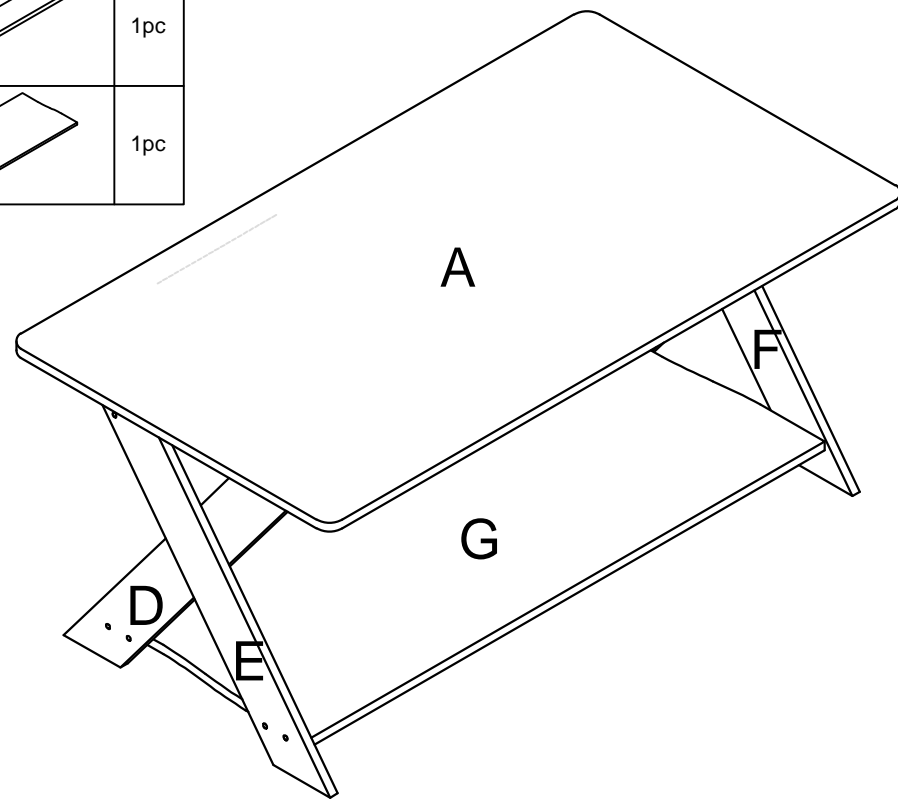

**USEFUL HINTS BEFORE YOU START:**

1. Read each step carefully before starting.
2. It is important that each step is performed in correct order to avoid difficulties.
3. Identify, sort and count the parts before assembly.
4. Assemble your furniture on packaging cardboard to prevent scratch or damage.
5. Clean the product with mild cleanser using soft damped cloth. Do not use harsh or abrasive cleanser.
6. Using incompatible hardware might cause damage to product.

**ASSEMBLY INSTRUCTION**

1

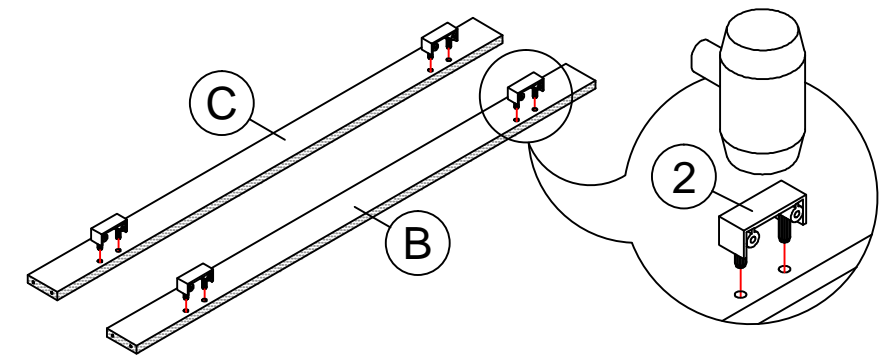

2

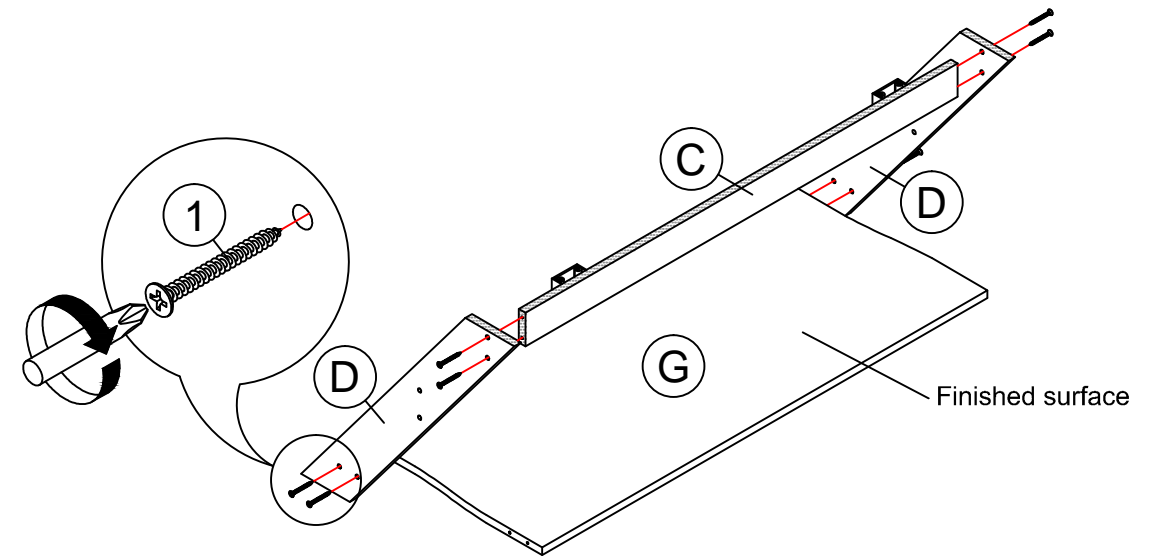

3

