

# Assembly Instructions

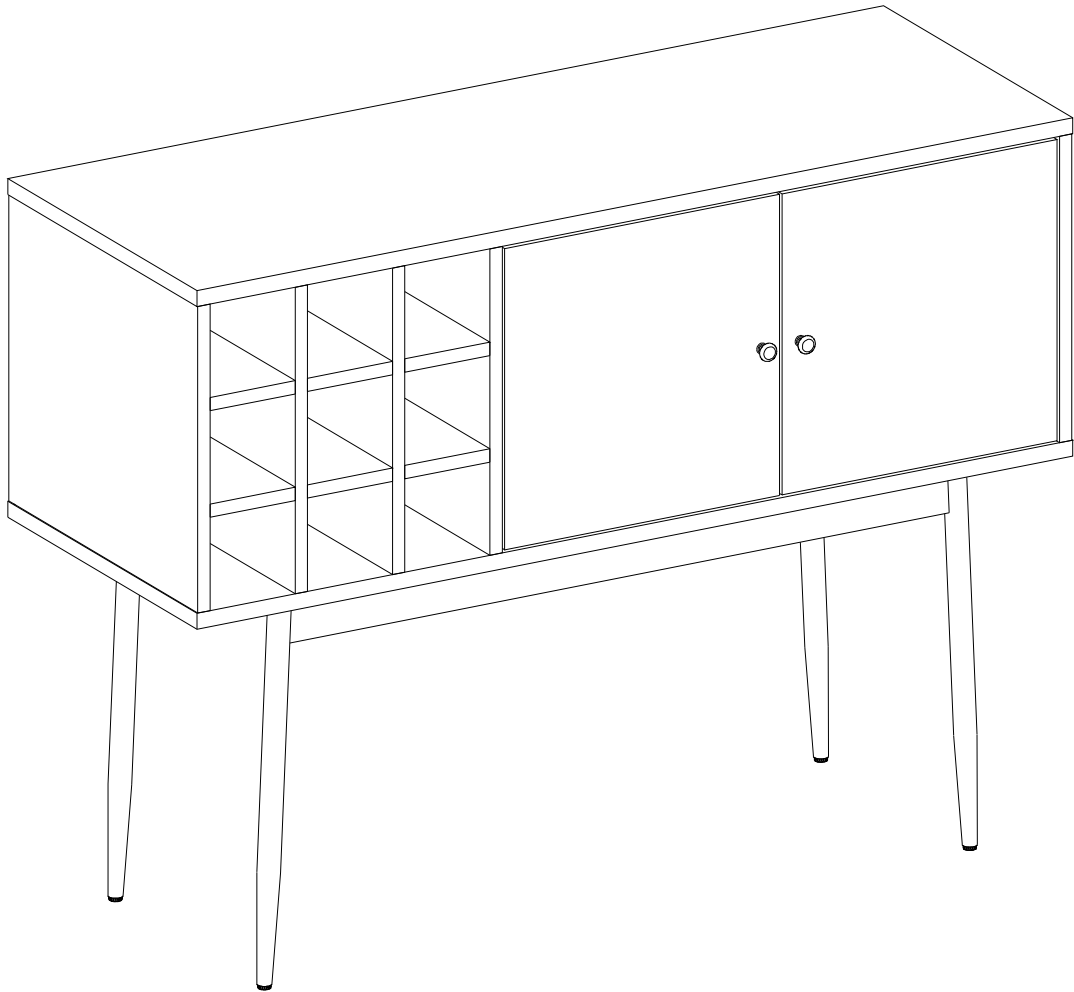

# General Assembly Guidelines

- I. Ensure that all parts and hardware are available before beginning assembly.
- II. Follow each step carefully to ensure the proper assembly of this product.
- III. Two people are recommended for ease in the assembly of this product.
- IV. The three main types of hardware used to assemble this product are : wood dowels , screws and bolts.
- V. The provided glue is to secure wood dowels in place . When first inserting dowels , locate the appropriate hole for the dowel , place a small amount of glue in the hole and insert the dowel . Wipe away excess glue immediately.

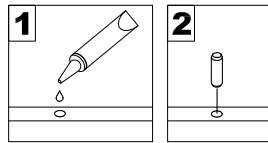

In future assembly steps when dowels are necessary to attach assembly parts together , place a small amount of glue on the end of the dowel before attaching parts together . Wipe away excess glue immediately.

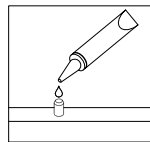

- VI. A Phillips head screwdriver is required for the assembly of this product .

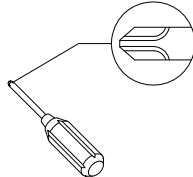

- VII. Power tools should not be used to assemble this product .

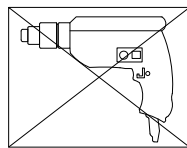

- VIII. Concealed hinges are three-way adjustable.

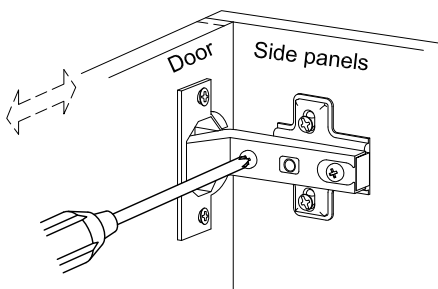

Horizontal  
by screw adjustment

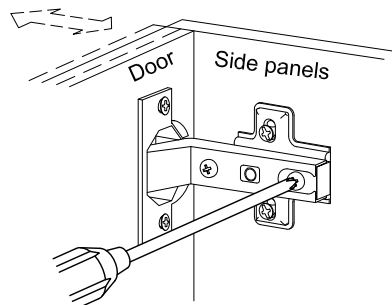

In-and-Out  
by loosening the hinge-arm  
mounting screw or via cam  
adjustment

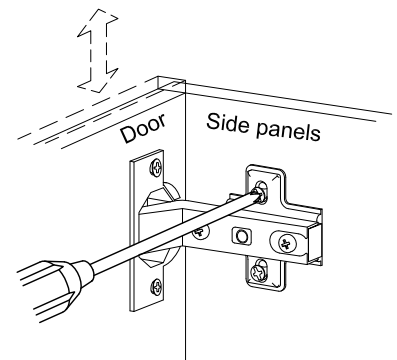





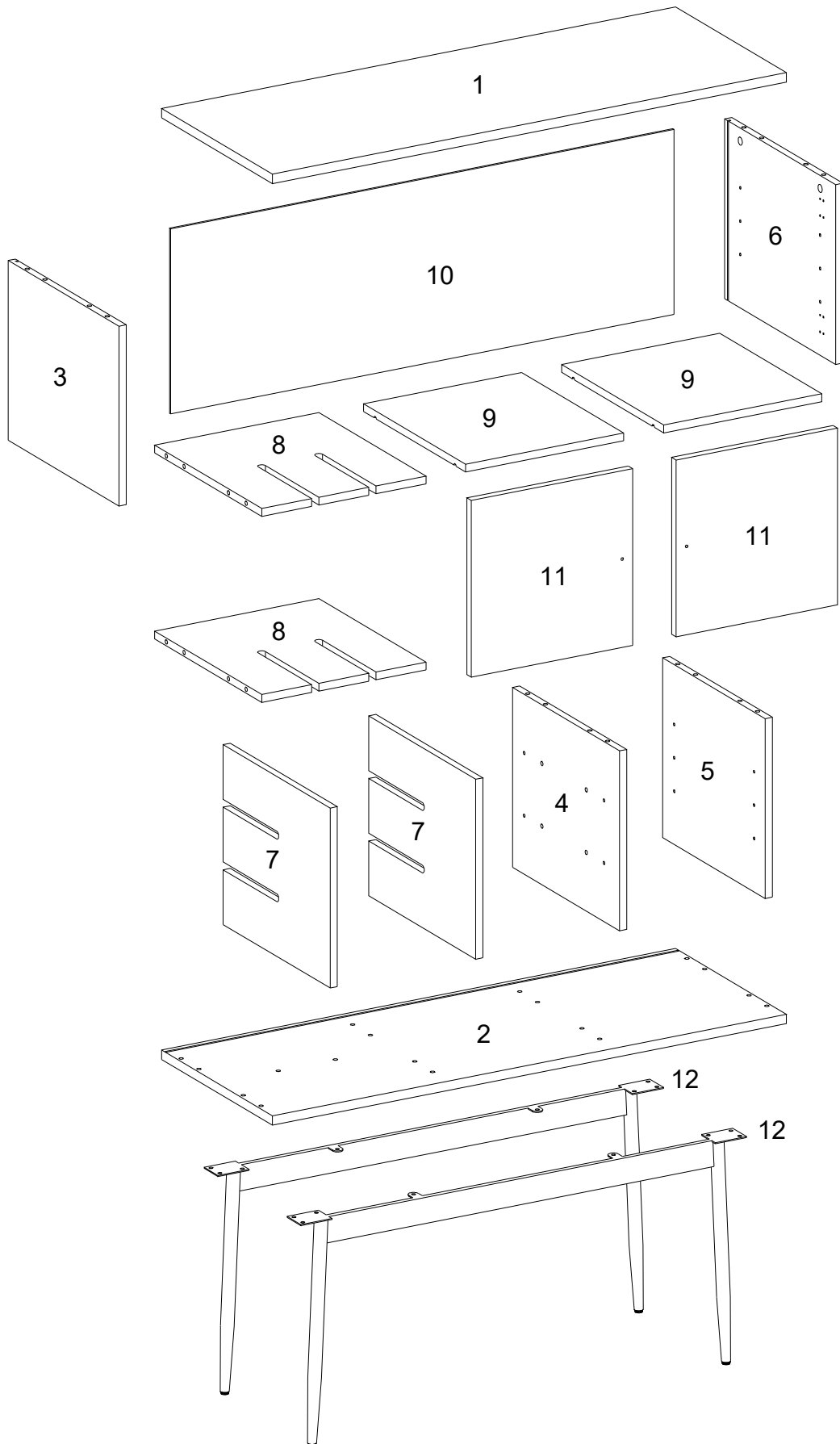



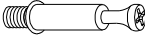

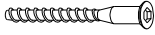



Vertical  
Via slots in the mounting  
plate or via cam adjustment

# Parts List

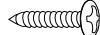
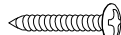

# Hardware List

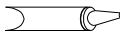
A		Ø8x30mm	Wooden dowel	24	pcs
B		Ø6x35mm	Cam bolt	16	pcs
C		Ø15x11mm	Cam lock	16	pcs
D		Ø30mm	Sticker	16	pcs
E		Ø6x50mm	Screw	10	pcs
F		Ø6x12mm	Bolt	16	pcs
G		M 4	Hex key	1	pc
H			Handle	2	pcs
J		Ø4x19mm	Handle Bolt	2	pcs
K		Ø3x17mm	Screw	6	pcs
L			Plastic wedge	6	pcs
M		Ø3.5x14mm	Screw	24	pcs
N			Europe hinge	4	pcs
P			Shelf support pin	8	pcs
Q		Ø4x12mm	Screw	1	pc
R		Ø4x25mm	Screw	1	pc
S			Plastic strap	1	pc
T			Nut	1	pc
U			Glue tube	1	pc

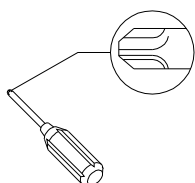

Philips head screwdriver required for assembly  
(not included)

*The hardware quantities listed above are required for proper assembly.  
Some extra hardware may also have been included.*

# Step 1

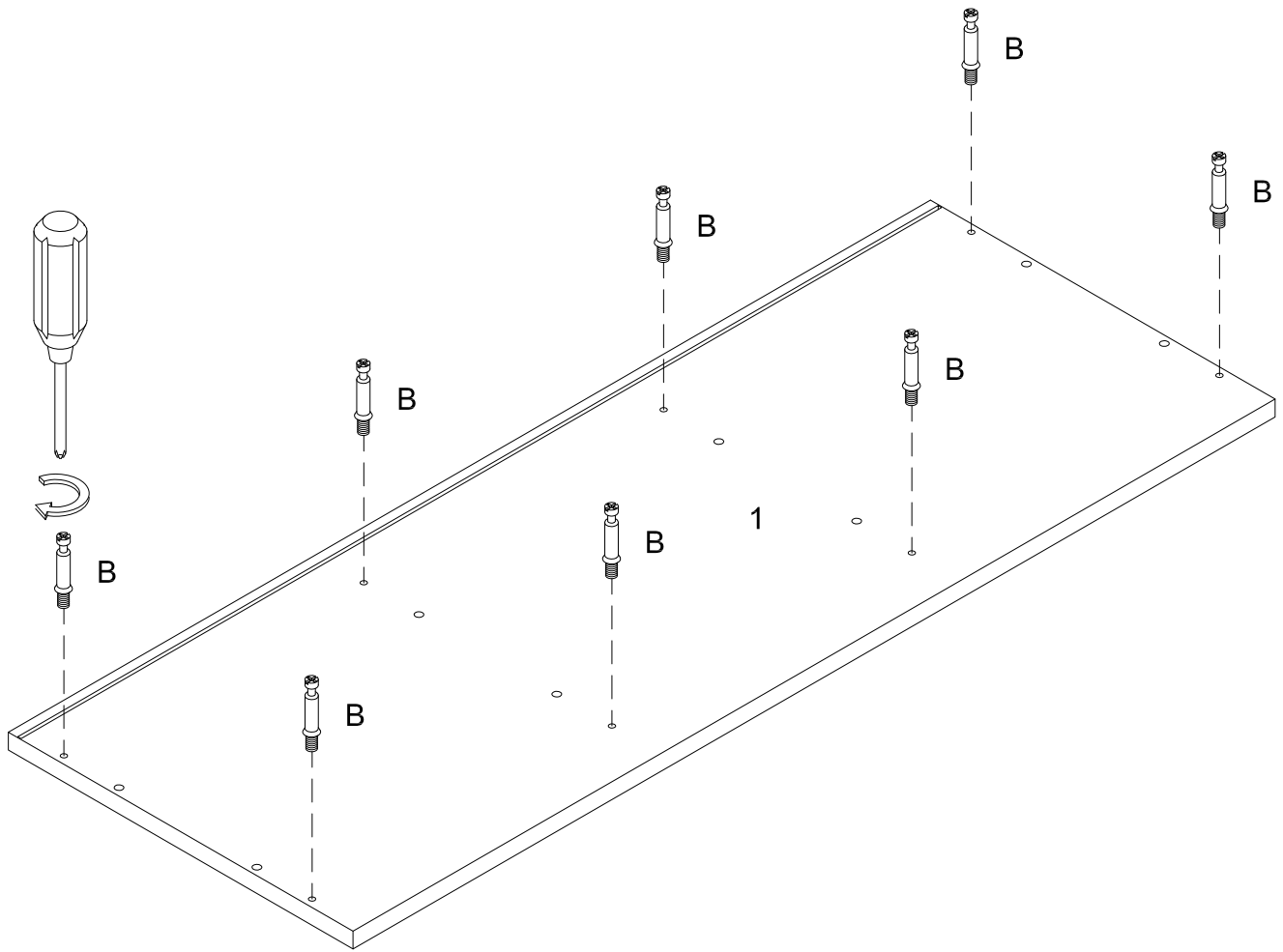

Secure cam bolt (B) into part (1) with Philips head screwdriver as per diagram.

## Step 2

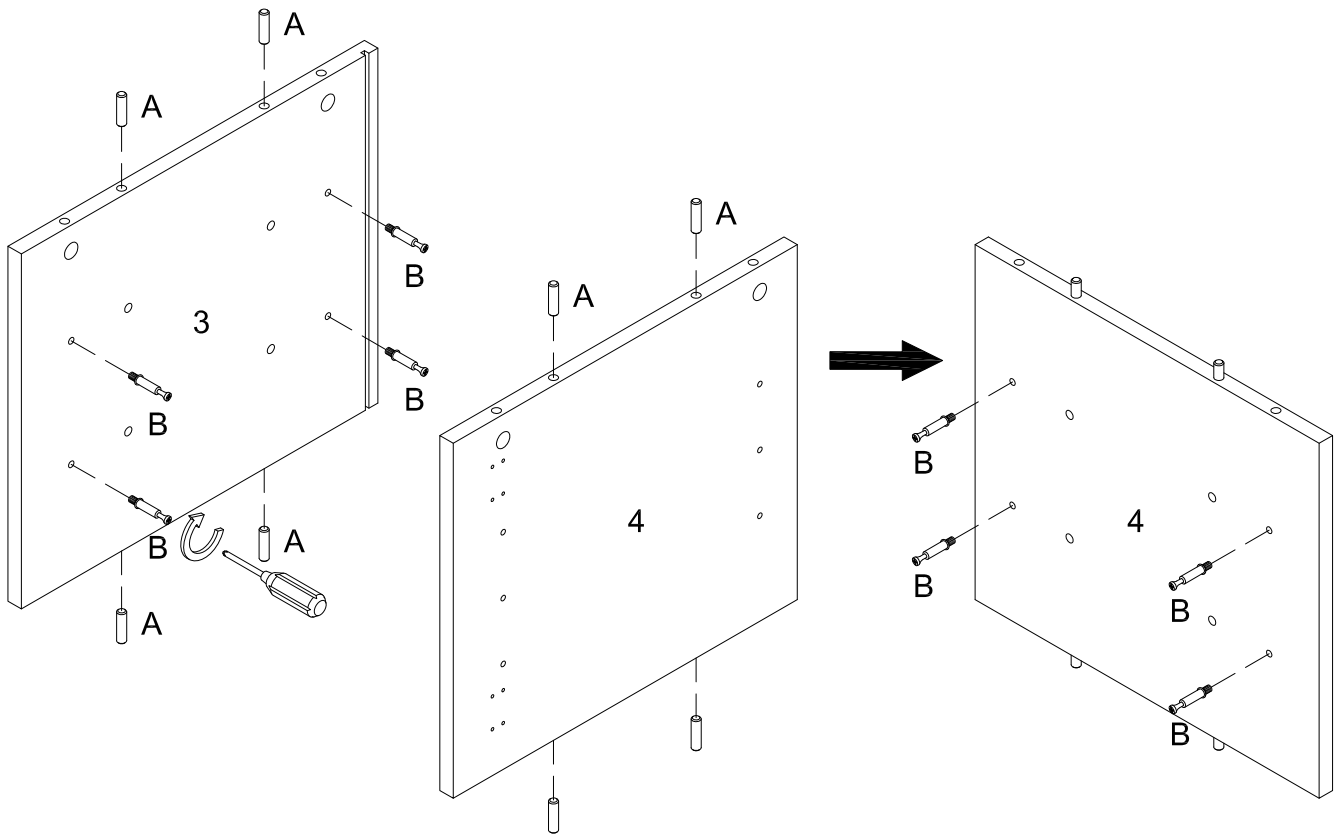

Insert wooden dowel (A) into parts (3,4), then secure cam bolt (B) into parts (3,4) with Philips head screwdriver as per diagram.

# Step 3

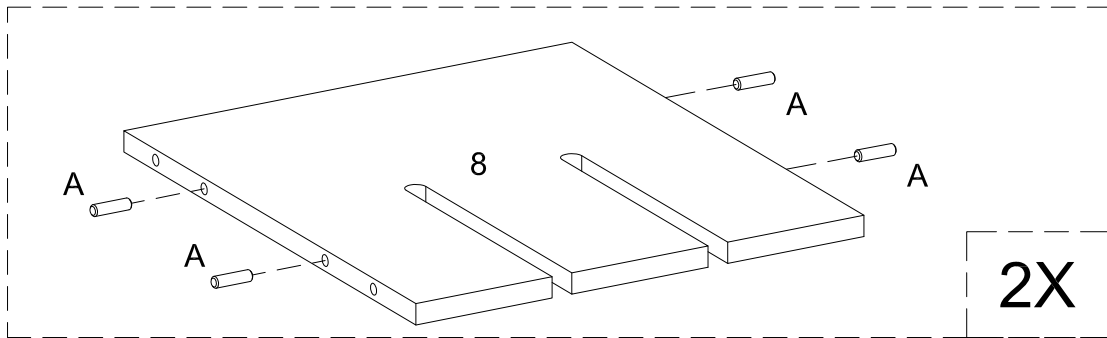
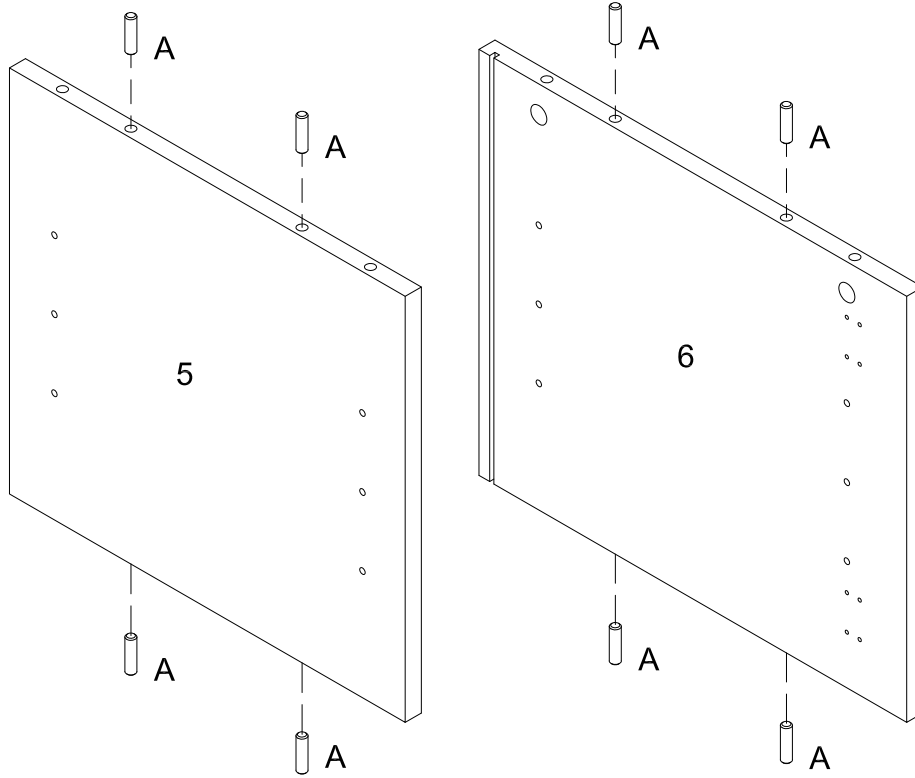

Insert wooden dowel (A) into parts (5,6,8) as per diagram.

# Step 4

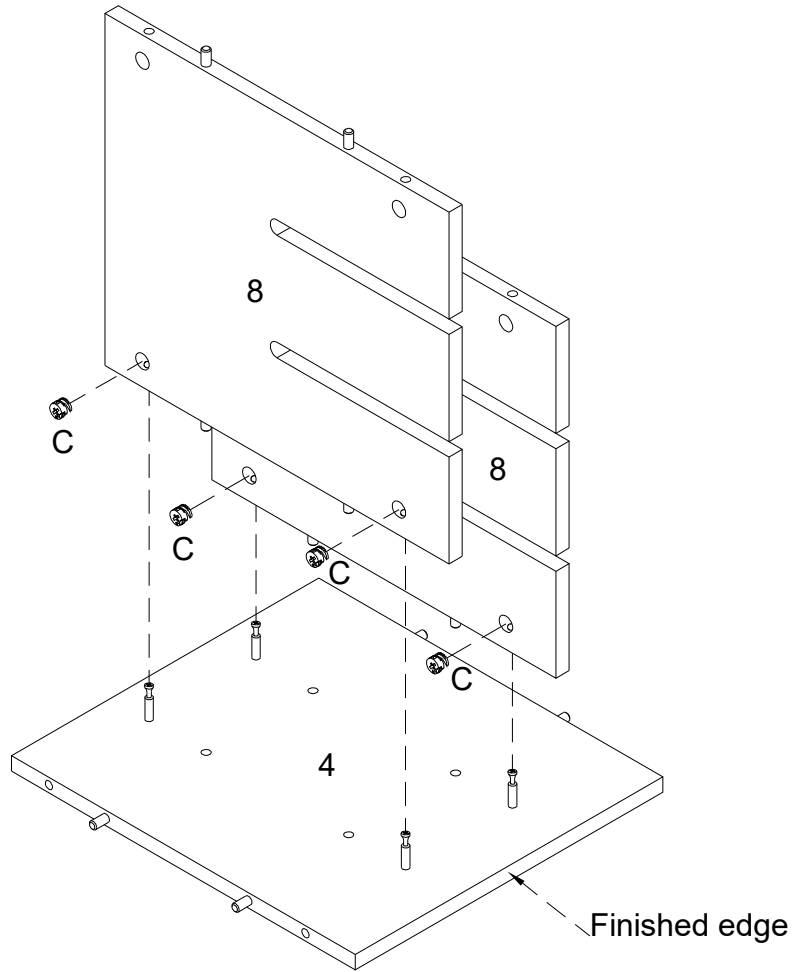
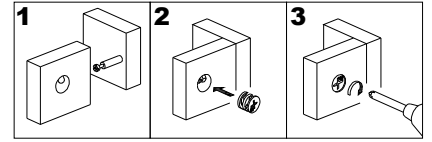

Using cam lock(C) secure part (8) to part (4) with Philips head screwdriver as per diagram.

# Step 5

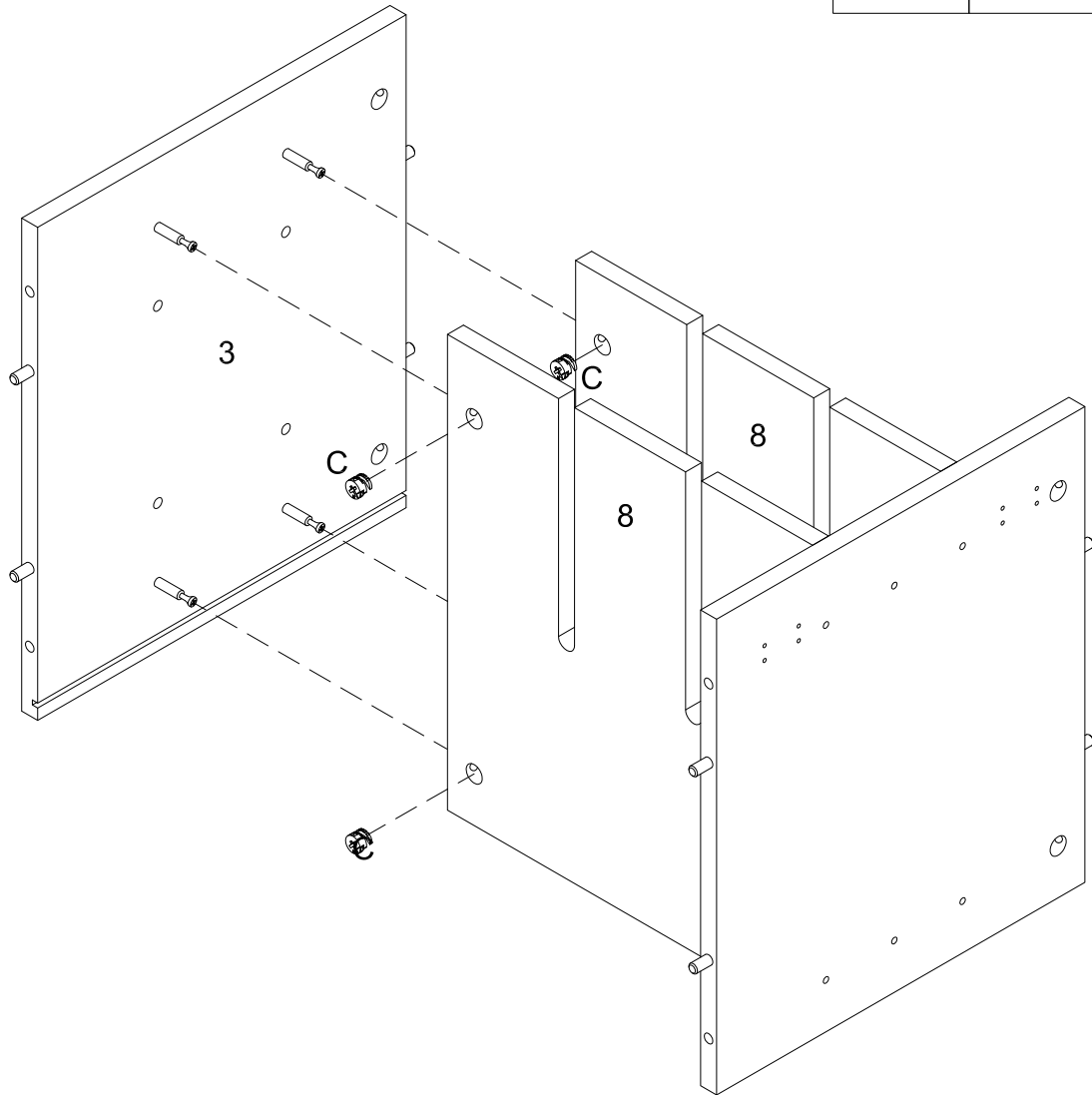
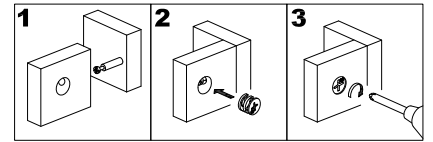

Using cam lock(C) secure part (3) to part (8) with Philips head screwdriver as per diagram.

# Step 6

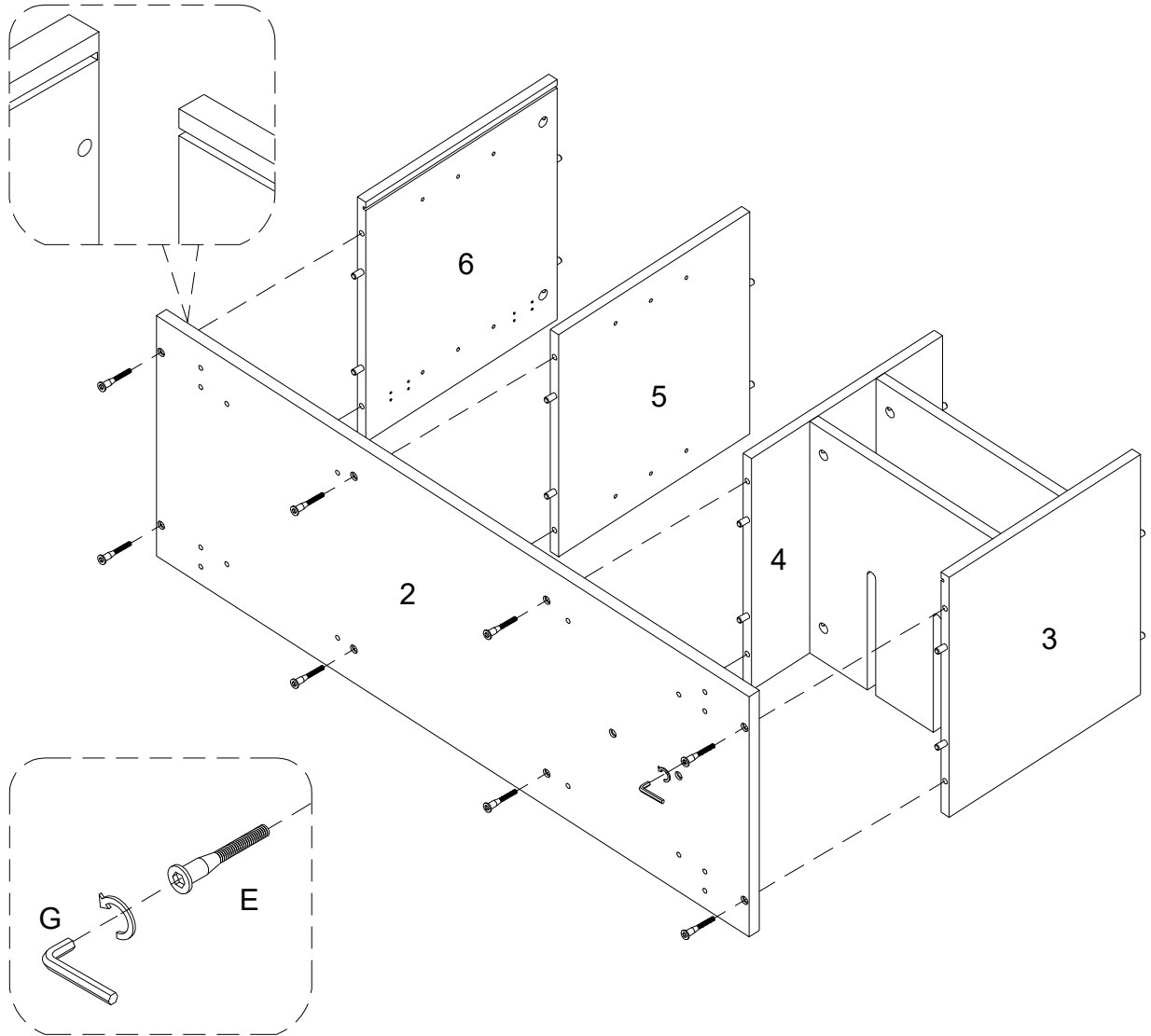

Using screw (E) attach part (2) into parts (3,4,5,6) with hex key (G) as per diagram.

# Step 7

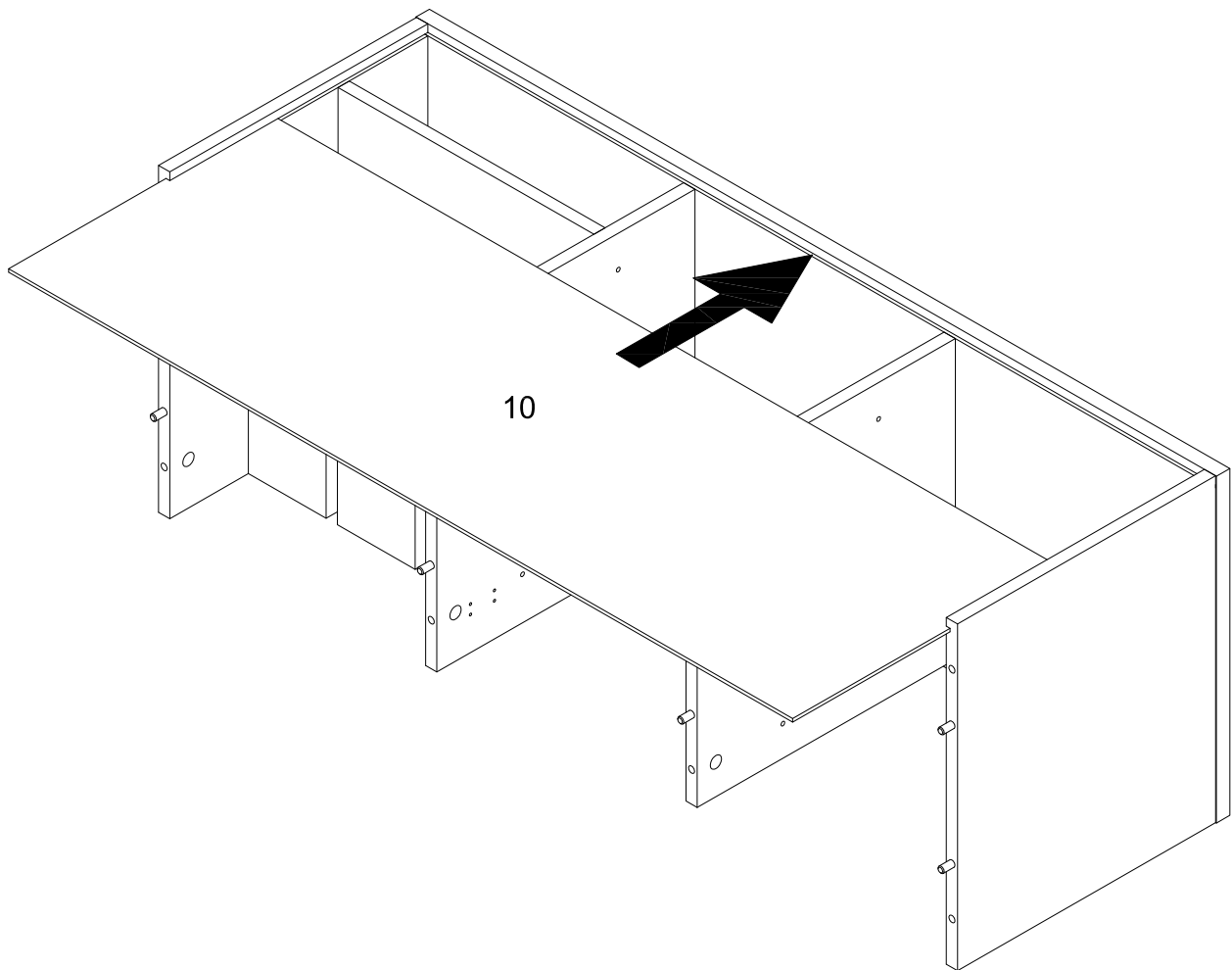

Put part (10) as per diagram.

# Step 8

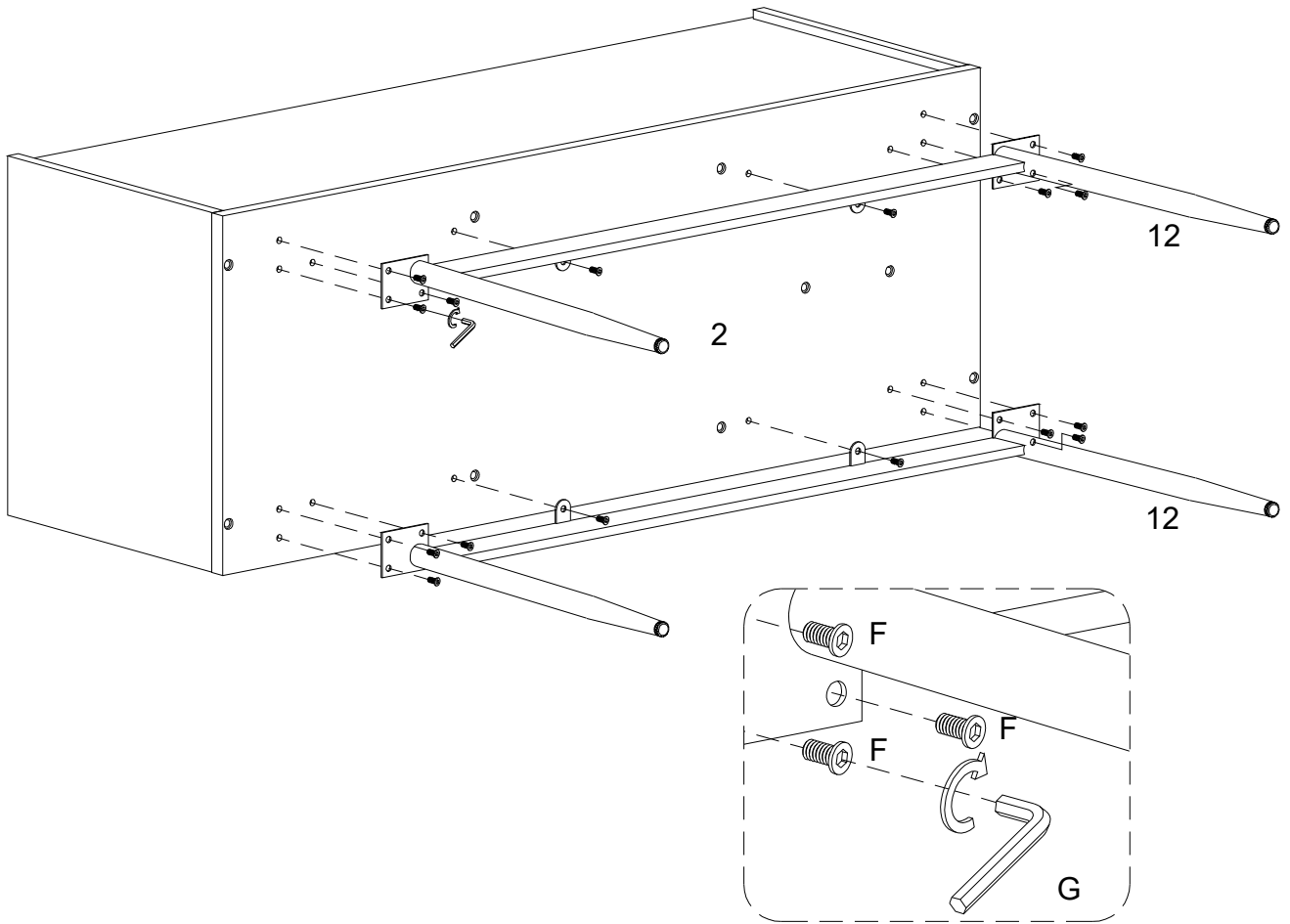

Using bolt (F) attach part (12) to part (2) with hex key (G) as per diagram.

# Step 9

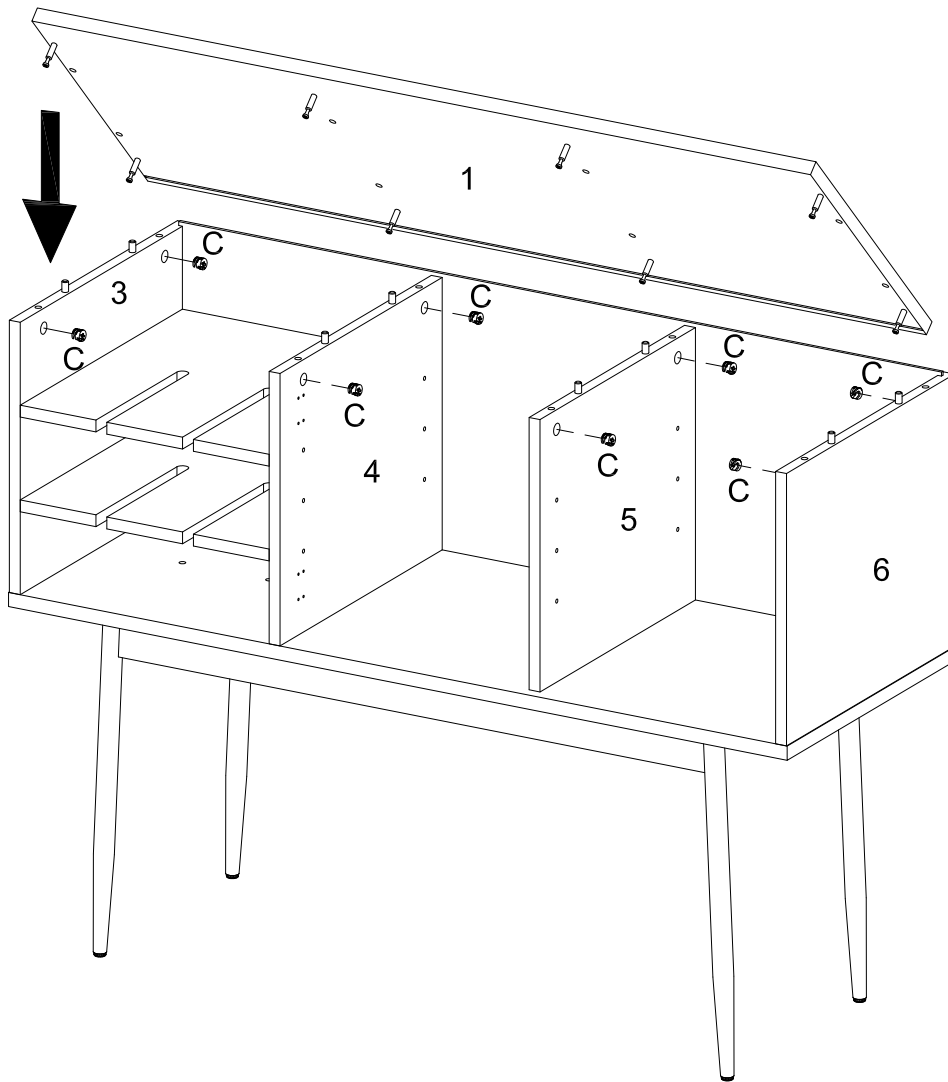
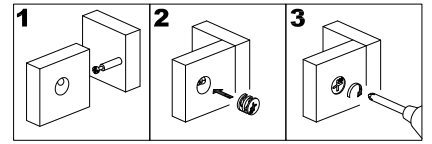

Using cam lock(C) secure part (1) to parts (3,4,5,6) with Philips head screwdriver as per diagram.

# Step 10

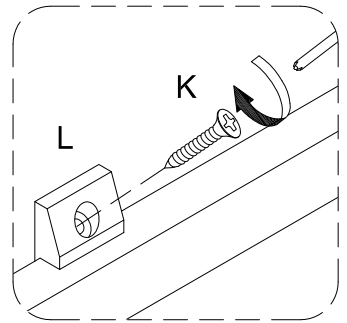
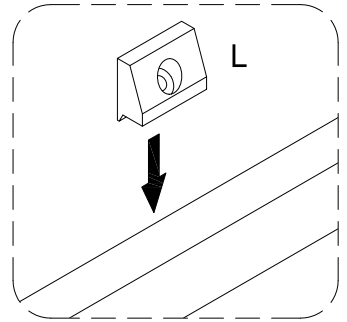
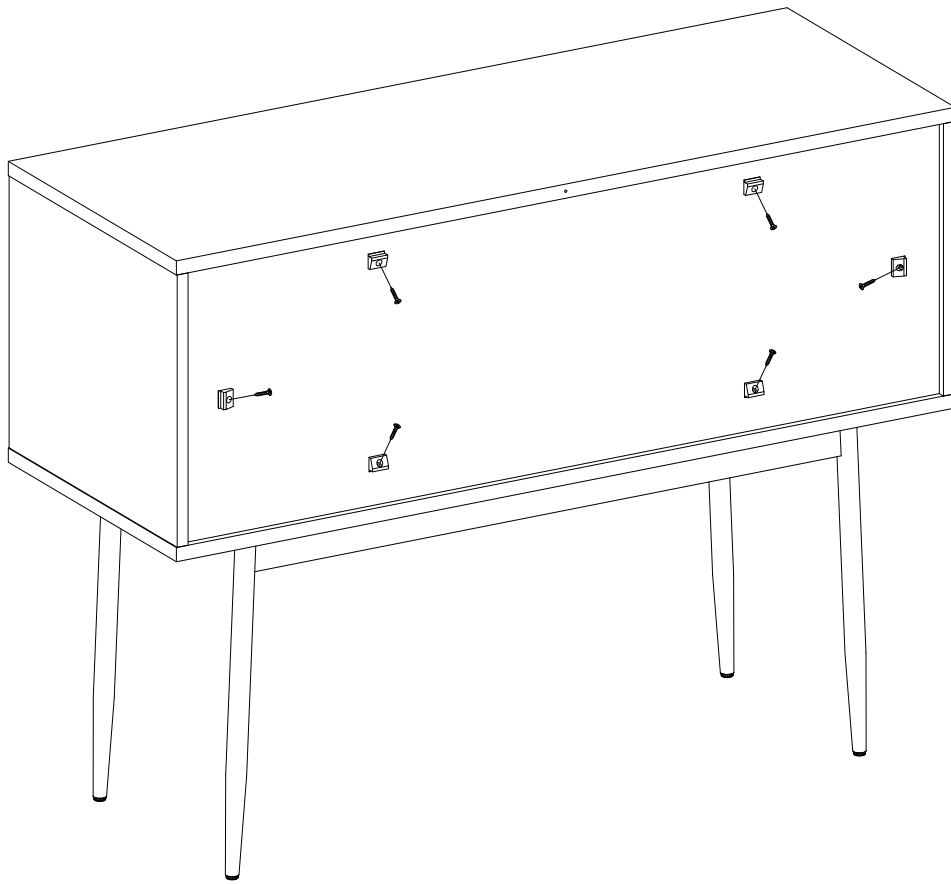

Using screw (K) secure plastic wedge (L) with Philips head screwdriver as per diagram.

# Step 11

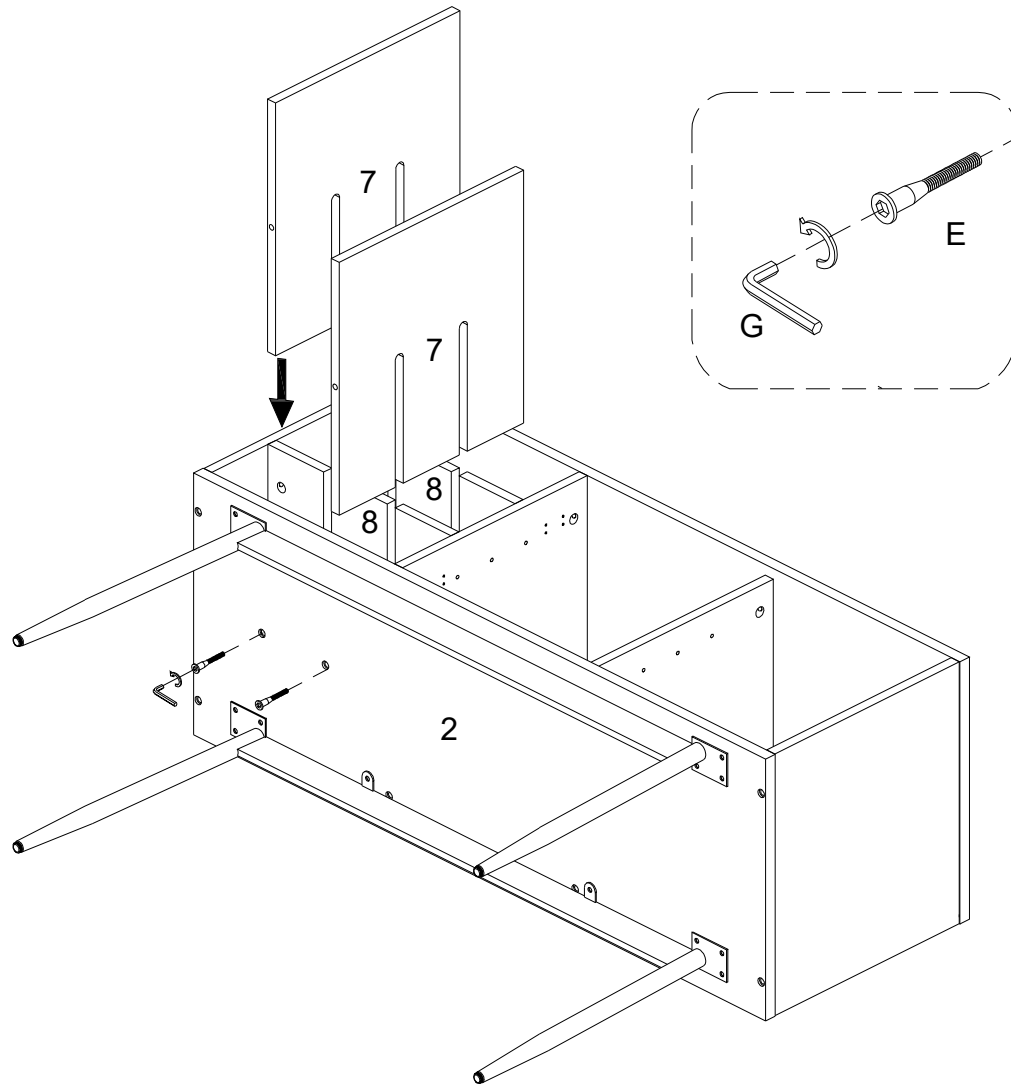

Put part (7) as per diagram. Using screw (E) attach part (2) into parts (7) with hex key (G) as per diagram.

# Step 12

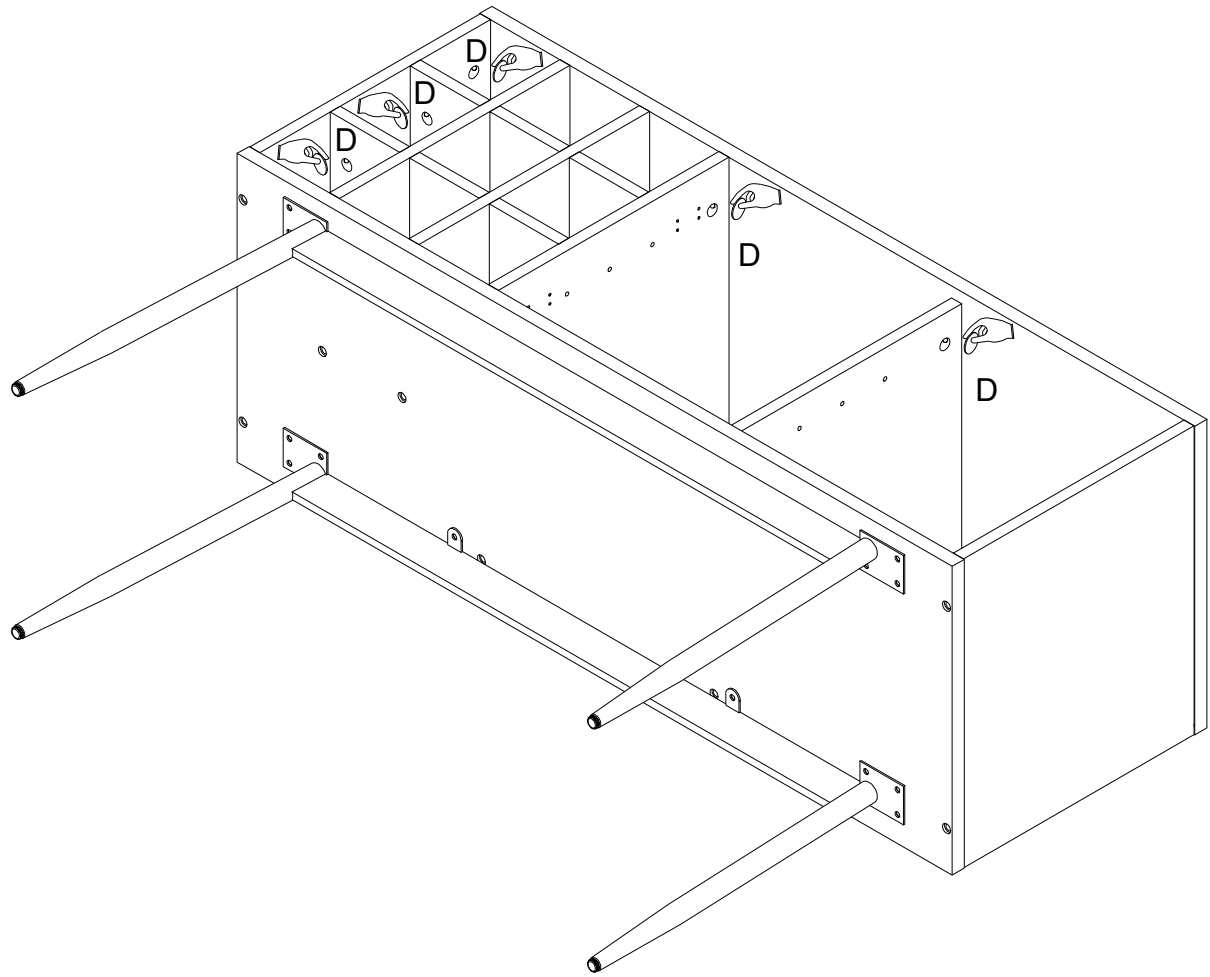

Place sticker (D) cover the holes as per diagram .

# Step 13

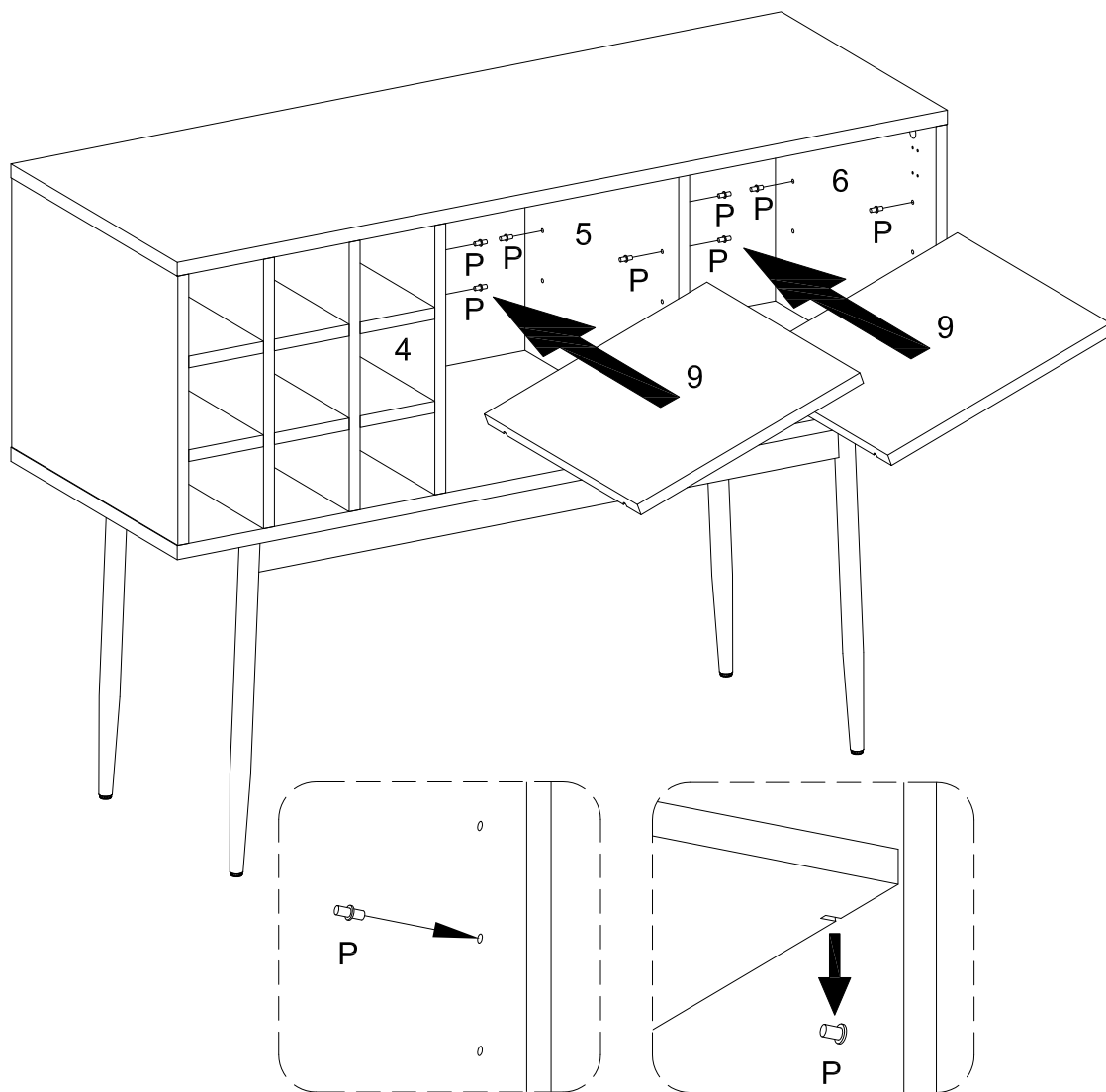

Insert shelf support pin (P) into parts (4,5,6) as per diagram. Make sure you place the four shelf support pins (P) in the same level. So the shelf is not titled .Put part (9) into unit as per diagram. Tilt and rest the adjustable shelf (9) onto the shelf support pins .

# Step 14

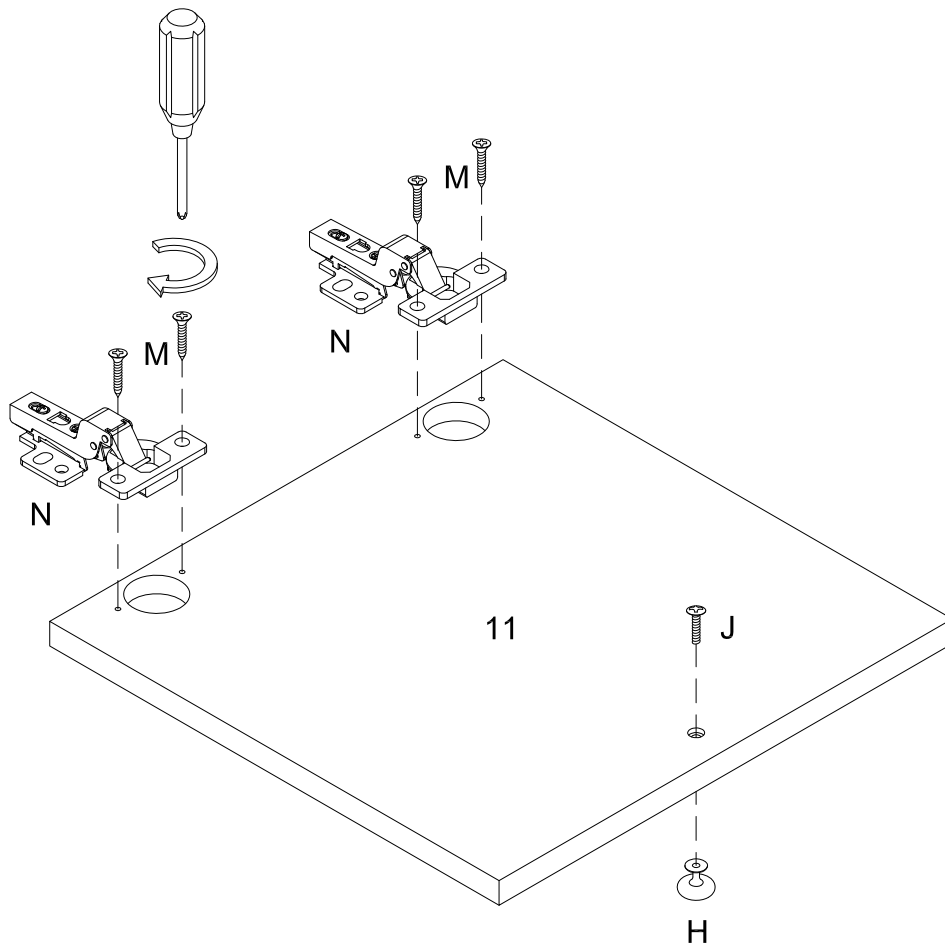

2X

Using handle bolt (J) attach part (11) into handle ,then using screw (M) attach Europe hinge (N) into part (11) with Philips head screwdriver as per diagram.

# Step 15

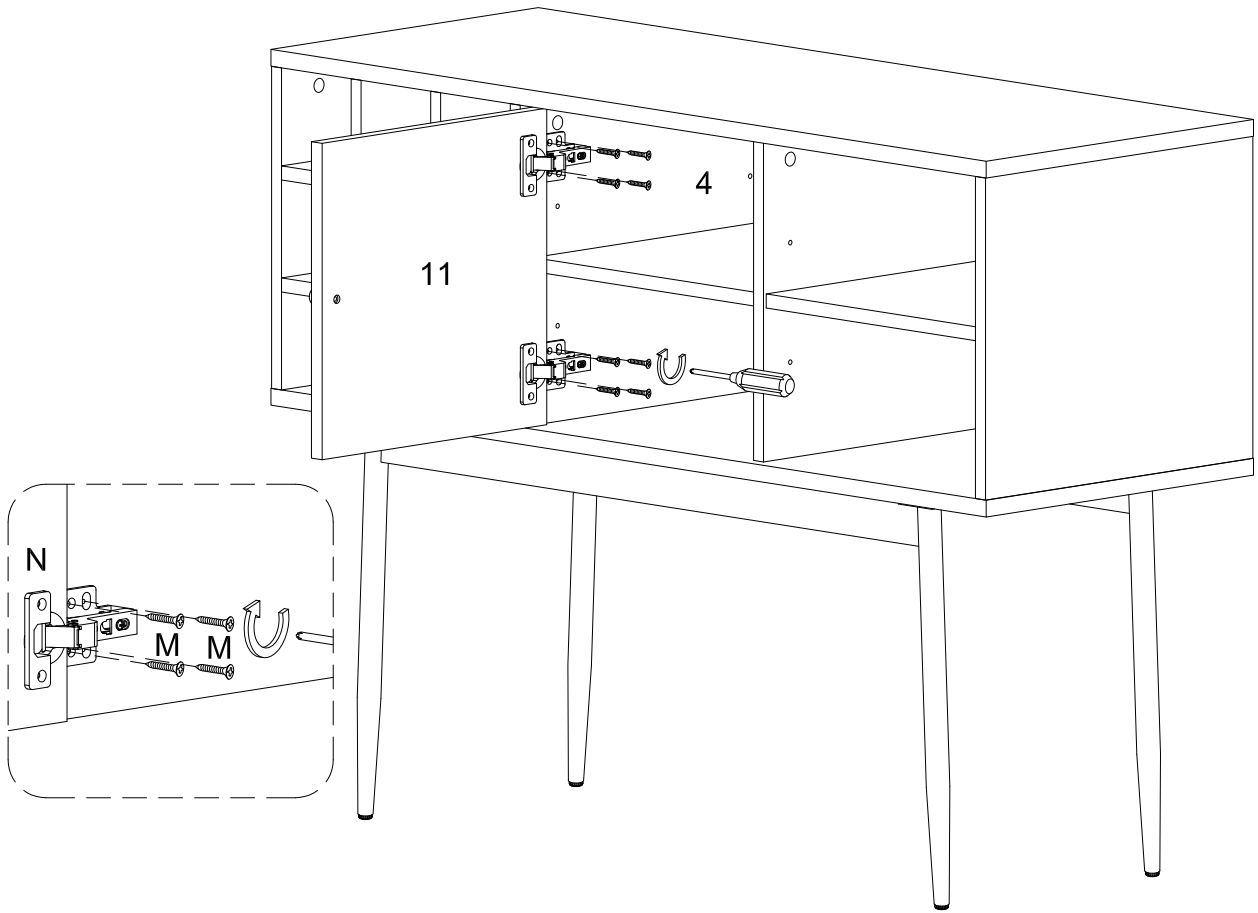

Using screw (M) attach Europe Hinge (N) into part (4) with Philips head screwdriver as per diagram.

# Step 16

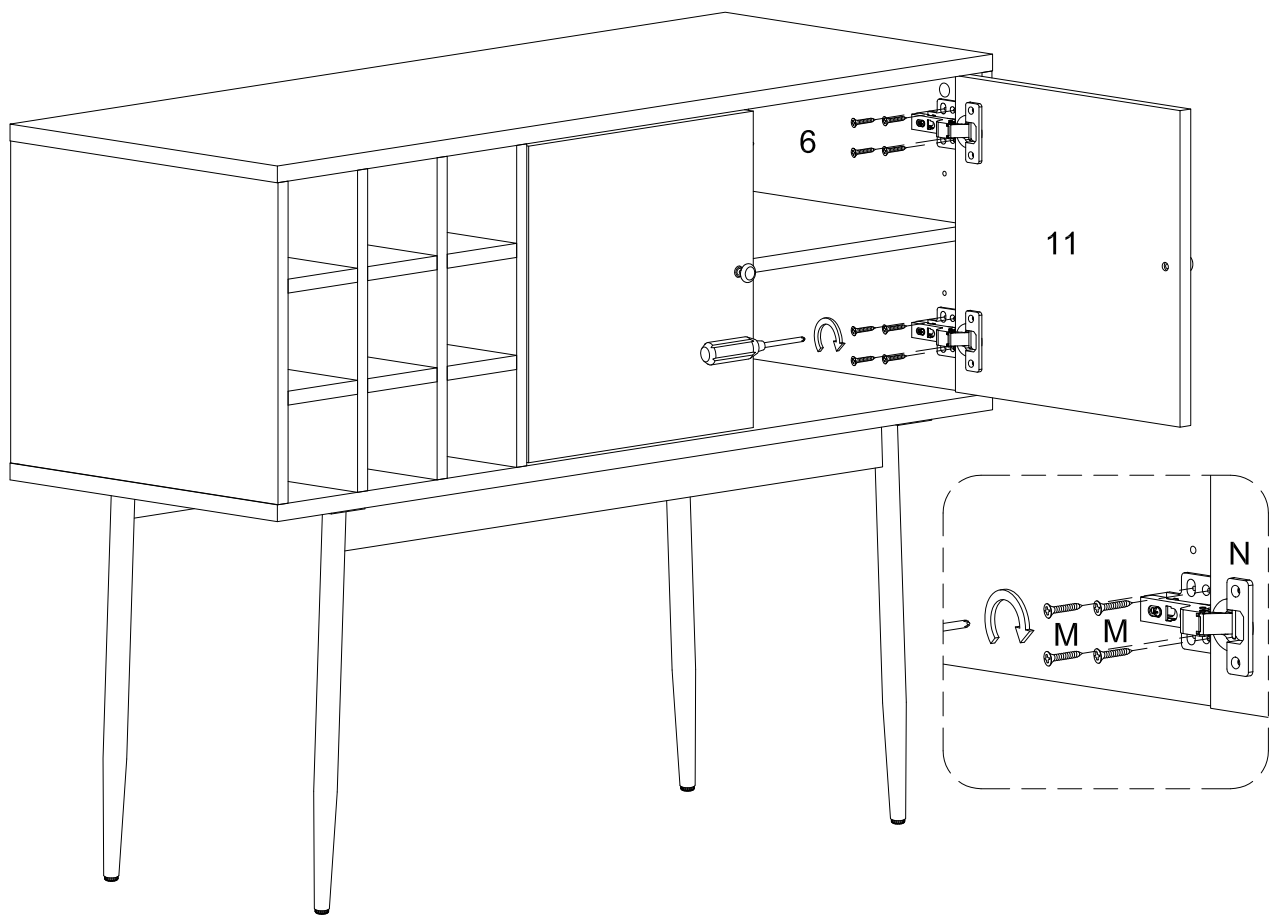

Using screw (M) attach Europe Hinge (N) into part (6) with Philips head screwdriver as per diagram.

# Step 17

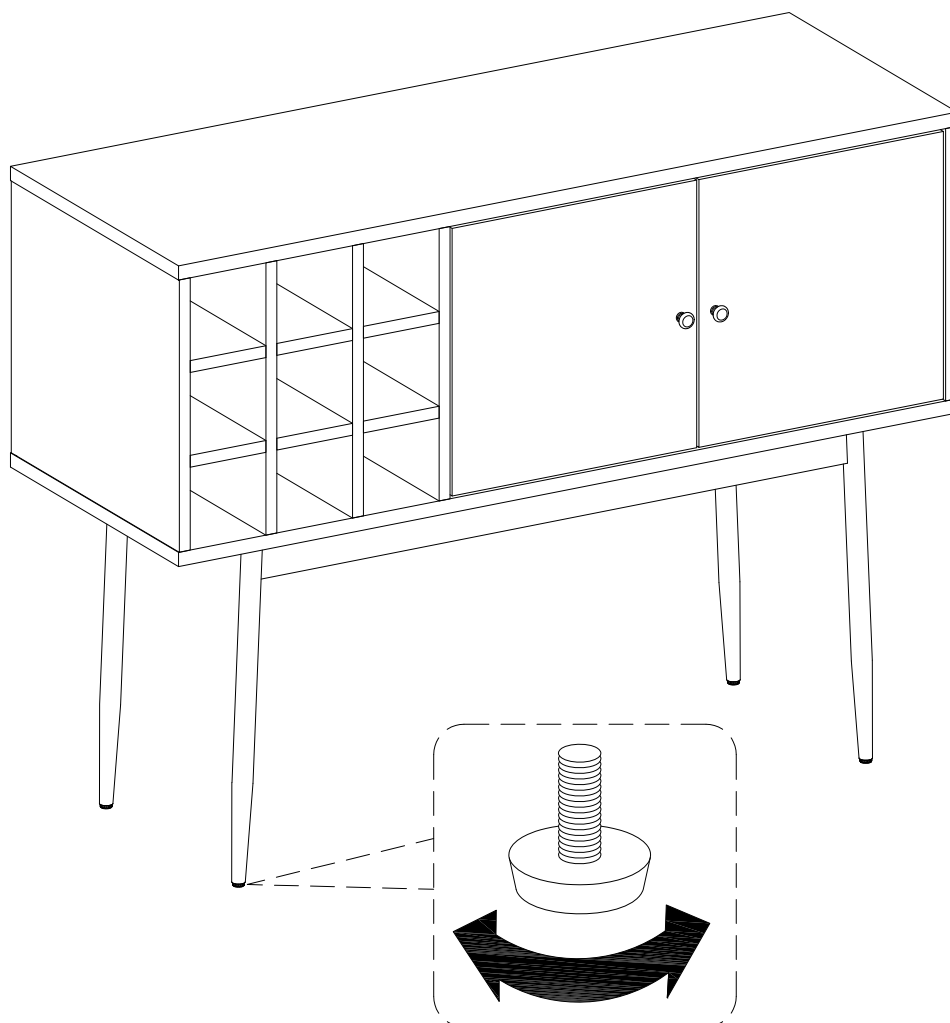

If necessary, adjust the pre-attached Floor Levelers at the bottom of metal legs to level the unit.

## Step 18

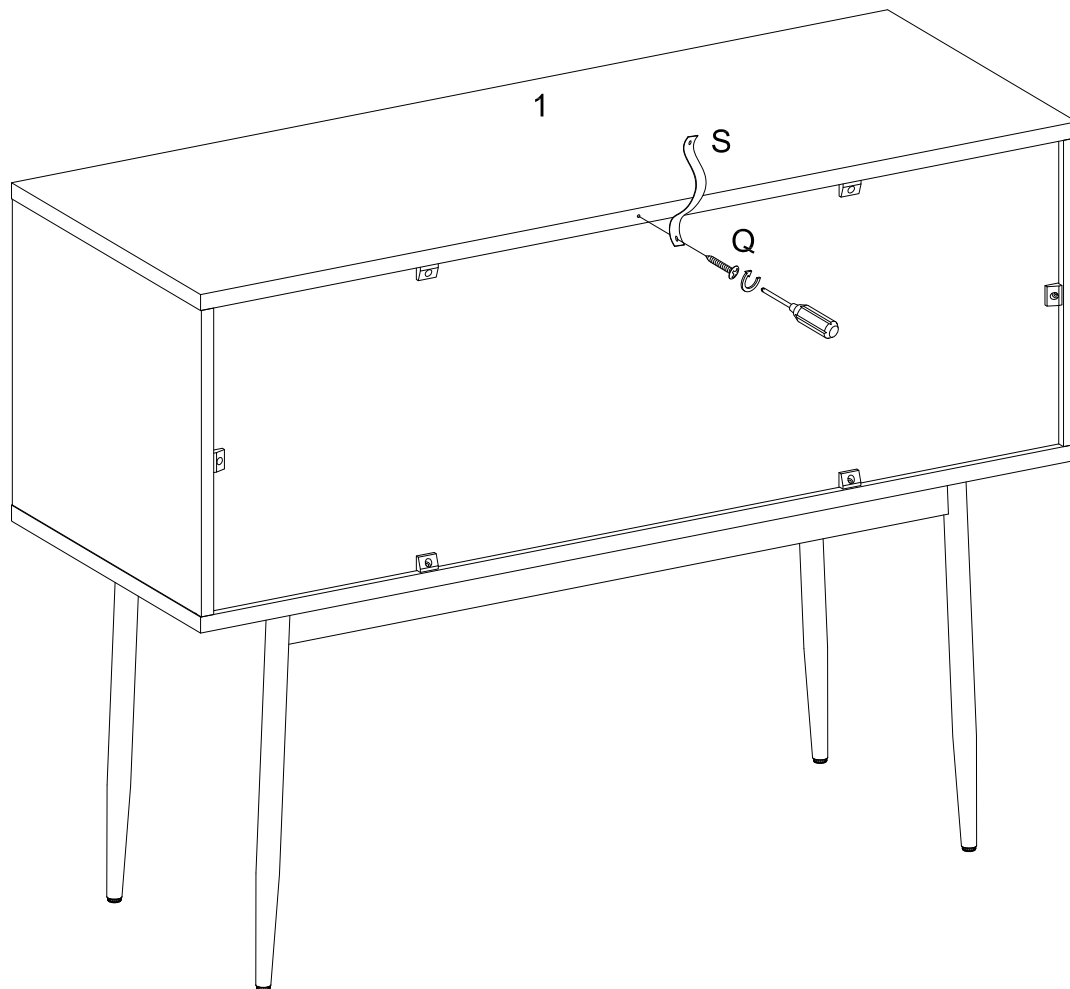

Using screw (Q) attach Velcro strap (S) into part (1) with Philips head screwdriver as per diagram.

# Step 19

## WARNING

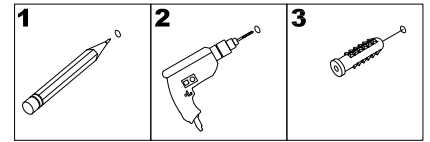

Serious or fatal injuries can occur from furniture tipping over. To prevent the furniture from tipping over we recommend that it is permanently fixed to the wall. Wall anchor and hardware are included with this product. Please make sure hardware is suitable for your walls before installing, as different wall materials may require different types of anchors.

Wall

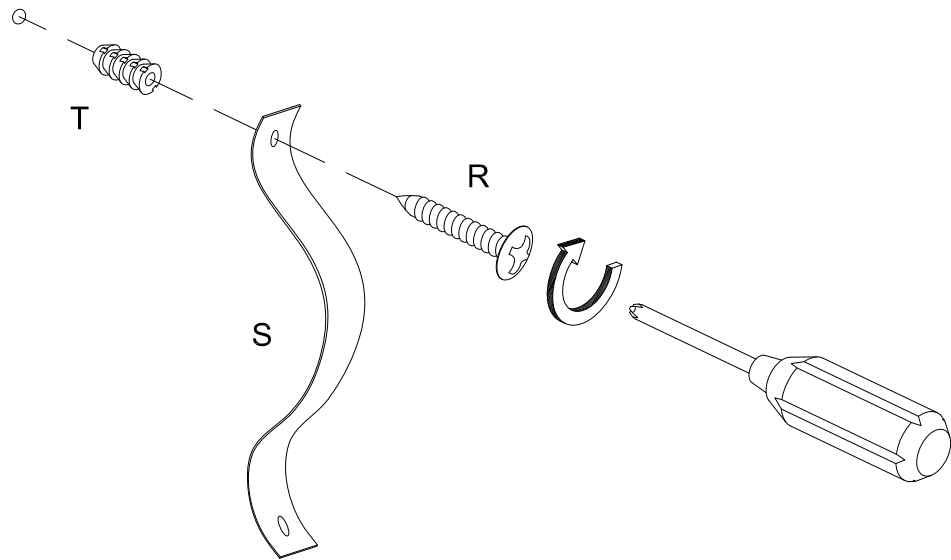

Using screw (R) attach Velcro strap (S) into Nut (T) to wall with Philips head screwdriver as per diagram.

# Step 20

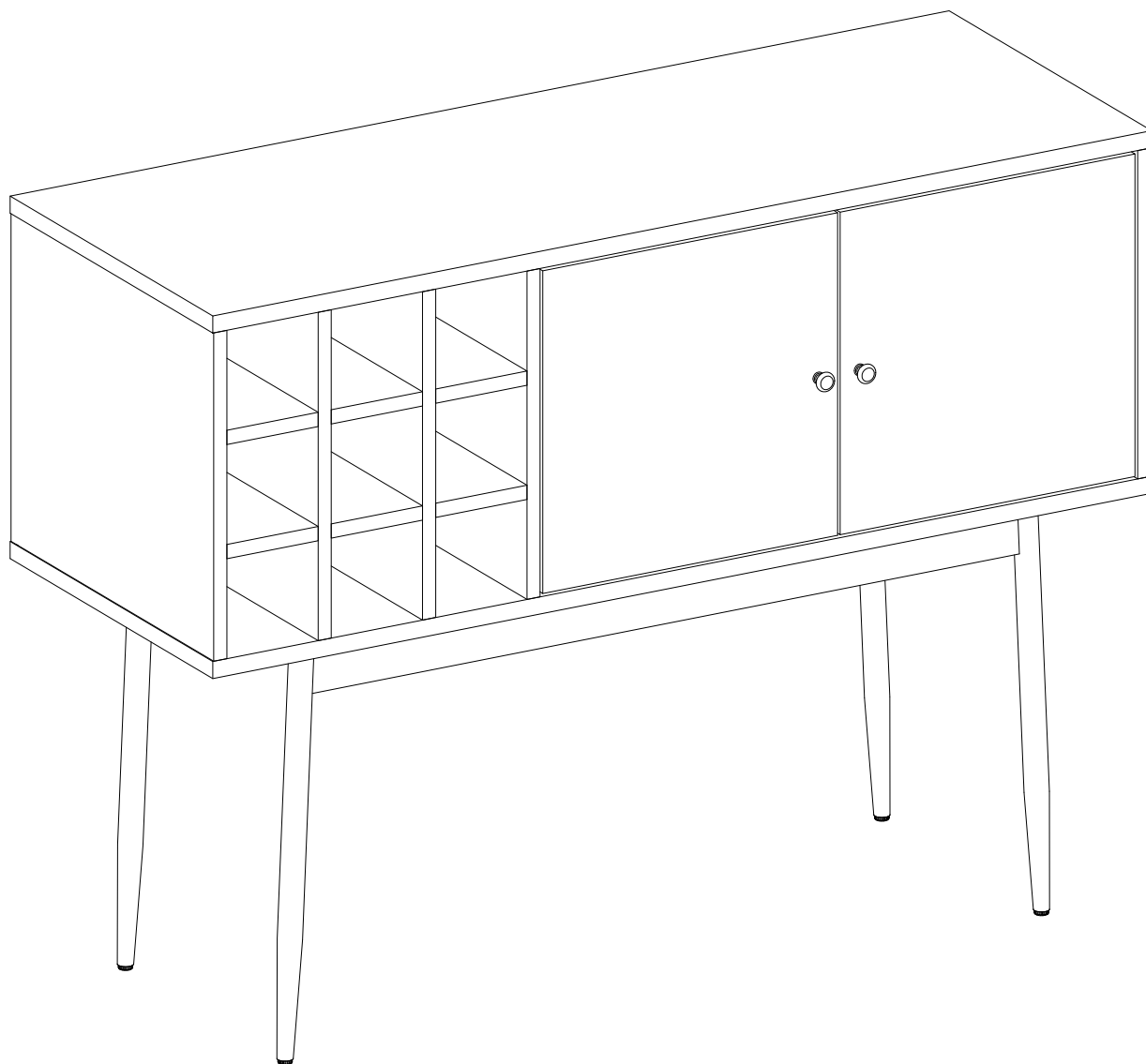

**Final Assembly**