

WRITING DESK

ASSEMBLY INSTRUCTIONS



ASSEMBLY TIPS:

1. Remove hardware from box and sort by size.
2. Please check to see that all hardware and parts are present prior to start of assembly.
3. Please follow attached instructions in the same sequence as numbered to assure fast & easy assembly.



Warning!

1. Don't attempt to repair or modify parts that are broken or defective. Please contact the store immediately.
2. This product is for home use only and not intended for commercial establishments.

PARTS IDENTIFICATION :

A) TOP FRAME - 1PC

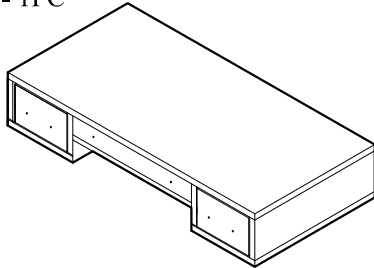

B) LEFT TABLE LEG- 1PC

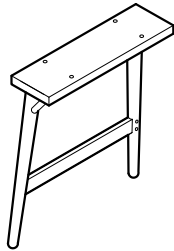

C) RIGHT TABLE LEG - 1PC

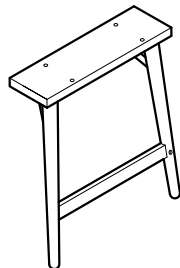

D) BOTTOM RAIL - 1PC

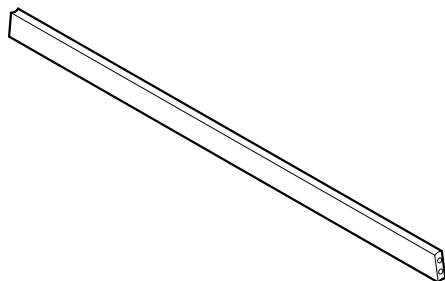

HARDWARE IDENTIFICATION :

1.SHORT BOLT - 8PCS

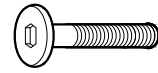

2.LONG BOLT - 2PCS

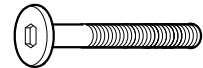

3. FLAT WASHER - 8PCS



4. BARREL NUT - 2PCS



5. PAN HEAD BOLT - 6PCS

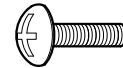

6. ALLEN WRENCH - 1PC



7. WOOD DOWEL - 2PCS

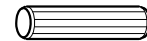

8. KNOB - 2PCS



9. PULL - 2PCS

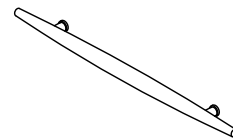

NOTE : PHILLIPS HEAD SCREW DRIVER IS REQUIRED
IN THE ASSEMBLY PROCESS.
HOWEVER, MANUFACTURER DOES
NOT PROVIDE THIS ITEM.

STEP 1

1.1) Insert wood dowel (7) to both ends of bottom rail (D)

1.2) Align and fasten bottom rail (D) to left (B) & right (C) table leg using long bolt (2) & barrel nut (4).
DO NOT FULLY TIGHTEN AT THIS STEP.

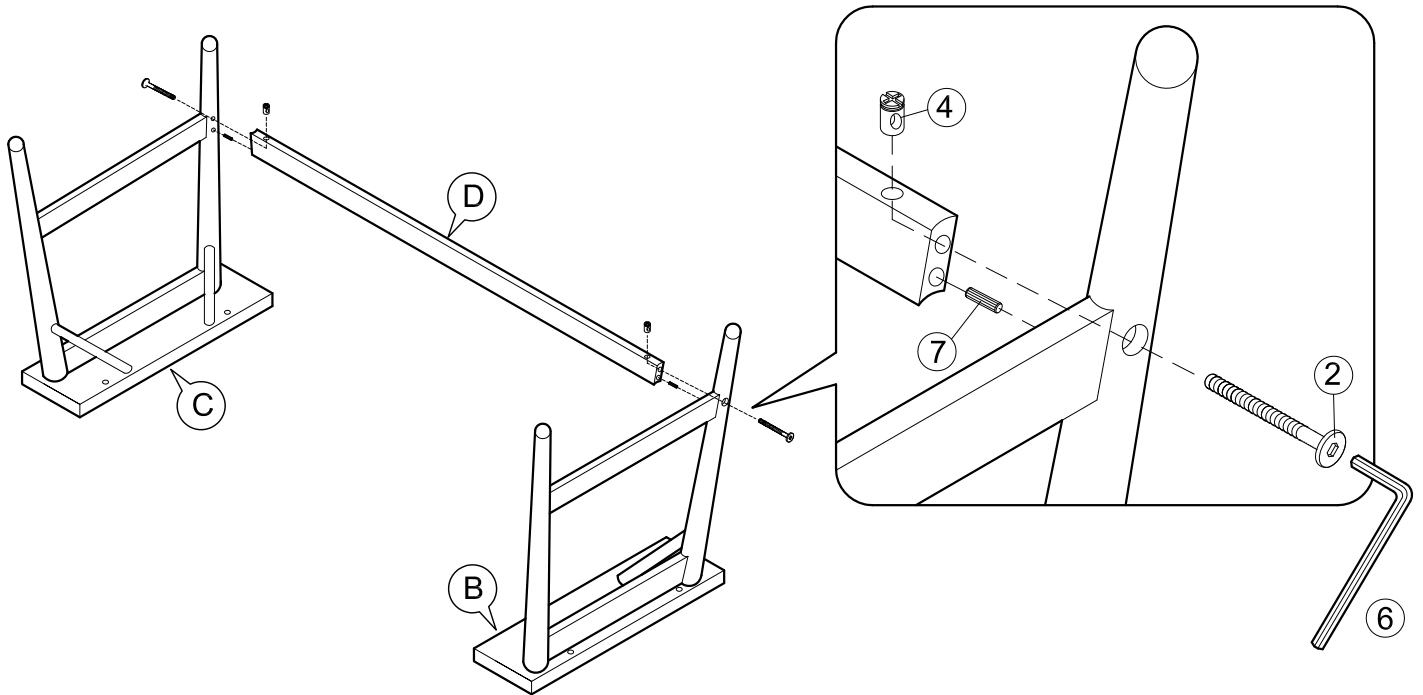

STEP 2

Align & fasten table leg (B & C) to top frame (A) using short bolt (1) & flat washer (3).

THEN FULLY TIGHTEN ALL THE BOLTS.

AT STEP 1.2 & 2 WITH ALLEN WRENCH (6).

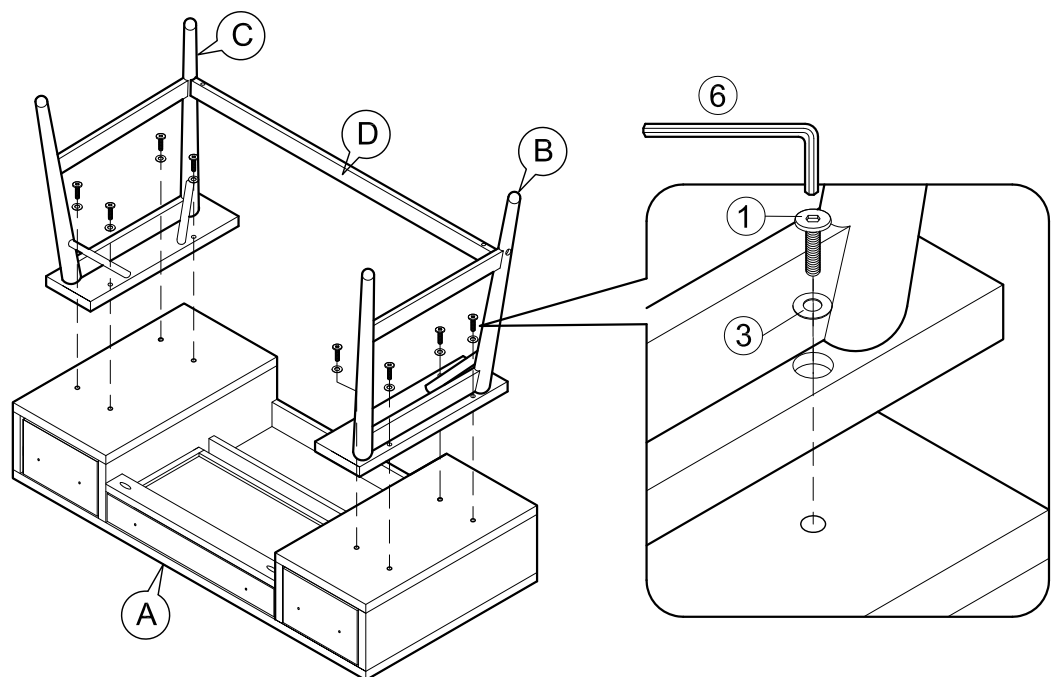

STEP 3

- 3.1) Align & fasten knob (8) to drawer front using pan head bolt (5) and fully tighten with Phillips head screw driver (NOT INCLUDED).
- 3.2) Align & fasten pull (9) to drawer front using pan head bolt (5) and fully tighten with Phillips head screw driver (NOT INCLUDED).

