

## NOTICE

- \* Please make sure that you have all parts indicated and they are in good condition before you begin assembly of this item. Refer to part list and hardware list below for guidance.
- \* This item should be assembled on a soft surface to prevent scratching the finish during assembly.
- \* This item may require periodic tightening.
- \* If you are having difficulty, our friendly Customer Care team is always here to help.



## PREPARATION

- \* Before beginning assembly of product, make sure all parts are present. Compare parts with part contents list and hardware contents list.
- \* If any part is missing or damaged, do not attempt to assemble the product.
- \* Estimated Assembly Time: **10 minutes**
- \* Tools Required for Assembly (included): **Allen Key**

## CARE AND MAINTENANCE

Blot up spills immediately, always use masters on table tops under beverages. Use trivets or mats under hot dishes or cookware. Clean with warm water and dry surface immediately after cleaning. Do not use cleaners that contain acid such as bathroom cleaners, grout cleaner, and tile cleaners. Do not use abrasive cleaners in either dry or liquid forms. Use a cleaner and polish formulated for marble surfaces.

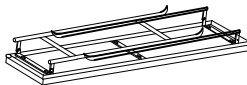
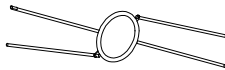
### Part List and Hardware List

PIECE	DESCRIPTION	PICTURE	QUANTITY
A	Metal Frame		1X
B	Back Support		1X
HW1	Bolt : M6 x 12 mm		4X
HW2	Allen key 3 MM		1X

# Owner Manual

PRODUCT DIMENSION : 42"W X 12"D X 30"H

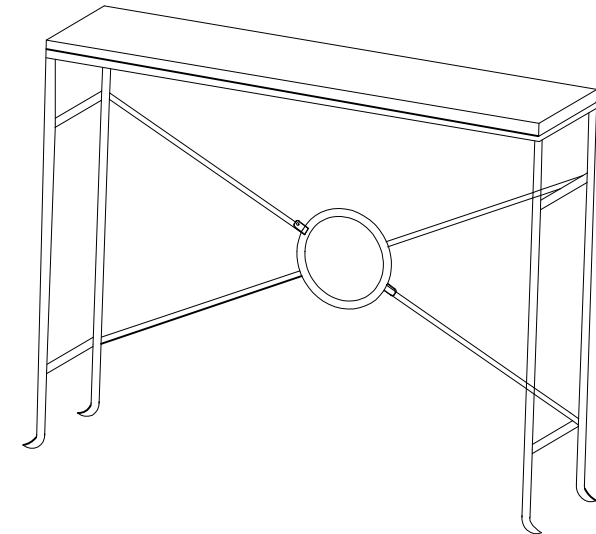

**WEIGHT CAPACITY : 60 LBS**

**WARNING : DO NOT OVER TORQUE BOLTS/SCREWS .**

**WARNING : DO NOT STAND ON THE CONSOLE TABLE.**

## PREPARATION

- \* Before beginning assembly of product, make sure all parts are present. Compare parts with part contents list and hardware contents list.
- \* If any part is missing or damaged, do not attempt to assemble the product.
- \* Estimated Assembly Time: 10 minutes.
- \* Tools Required for Assembly (included): Allen Key
- \* If you are having difficulty, our friendly Customer Care team is always here to help. Please email [customersupport@safavieh.com](mailto:customersupport@safavieh.com)

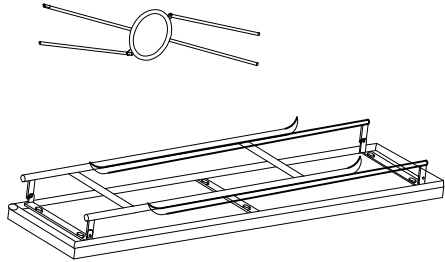

STEP1: OPEN THE ZIPPER ATTACHED ON THE CARTON AND TAKE OUT METAL FRAME(A) ,BACK SUPPORT (B) & HARDWARE BAG FROM THE CARTON.

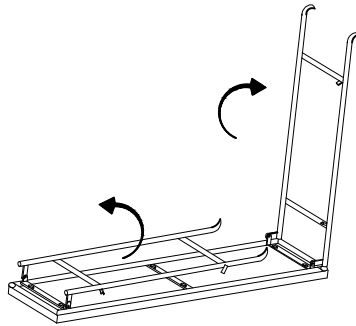

STEP2: UNFOLD BOTH THE LEGS AS SHOWN IN THE ABOVE PICTURE.

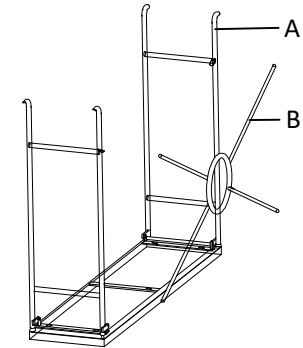

STEP3: AFTER UNFOLDING BOTH THE LEGS PLACE THE BACK SUPPORT (B) AS SHOWN IN THE ABOVE PICTURE.

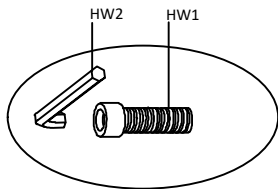

STEP4: PUT THE BOLT (HW1) & ALLEN KEY (HW2) ON THE BOLT IN THE ORDER SHOWN IN THE ABOVE PICTURE.

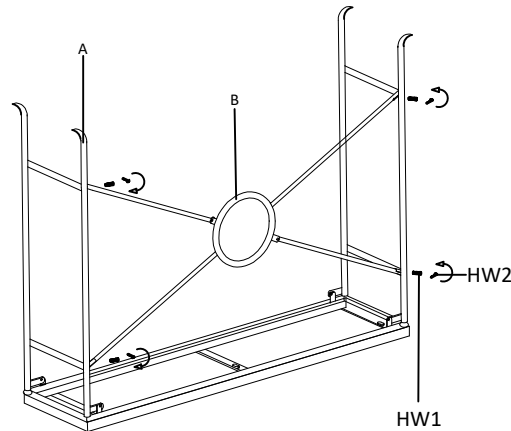

STEP5: THERE AFTER SCREW BOLTS & TIGHTEN THEM USING ALLEN KEY AS SHOWN IN THE ABOVE PICTURE.

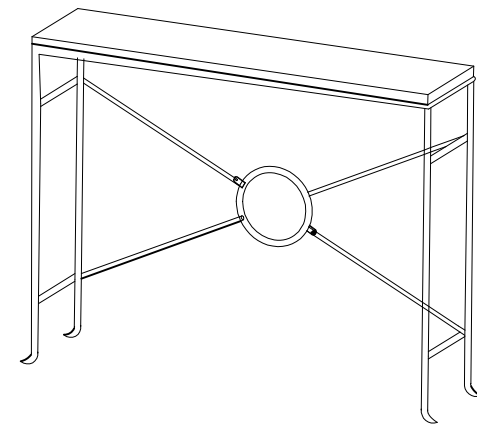

STEP 6: FINAL ASSEMBLED PIECE & IT IS READY TO USE.