

# Assembly Instructions

**Caution: You must read this before you proceed**

## Chair





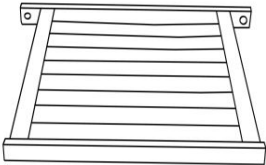
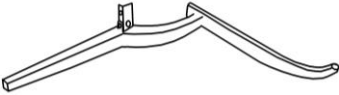

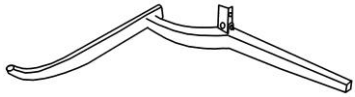
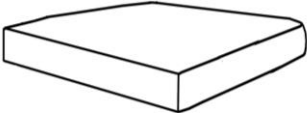
### Part List

Label	Picture	Description	QTY
A		Backrest with Back Leg	1
B		Seat Top	4
C		Left Front Leg	1

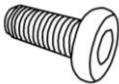
D		Right Front Leg	1
E		Cushion	1

## Hardware

Label	Picture	Description	QTY
①		Bolt (M8*15mm)	7
②		Allen Key (M8)	1
③		Bolt (M8*40mm)	3
④		Washer	12

## Assembly Preparation

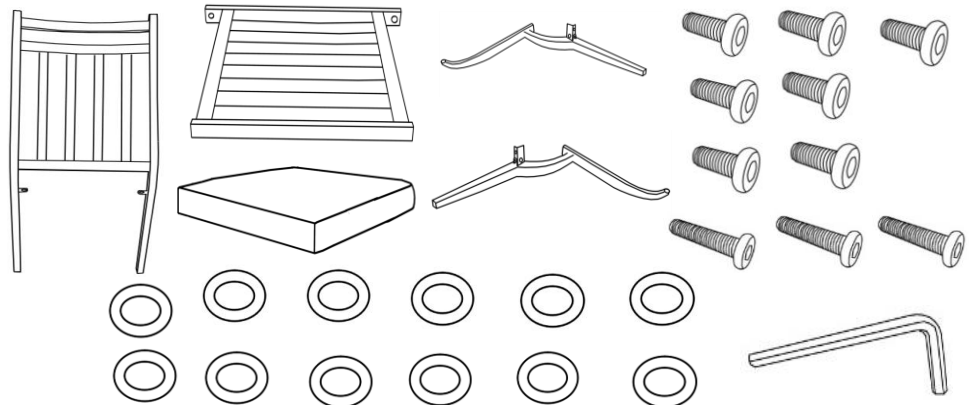
<p>Before Beginning Assembly:</p>	
-----------------------------------	--



- Read instructions, cover to cover-



- Have 2 adults on hand for assembly-



- Do not assemble on flooring or carpet-



- Assemble on a clean non-marring surface (packing foam)-



- Save all packaging until finished-

# Assembly Steps

## Overview

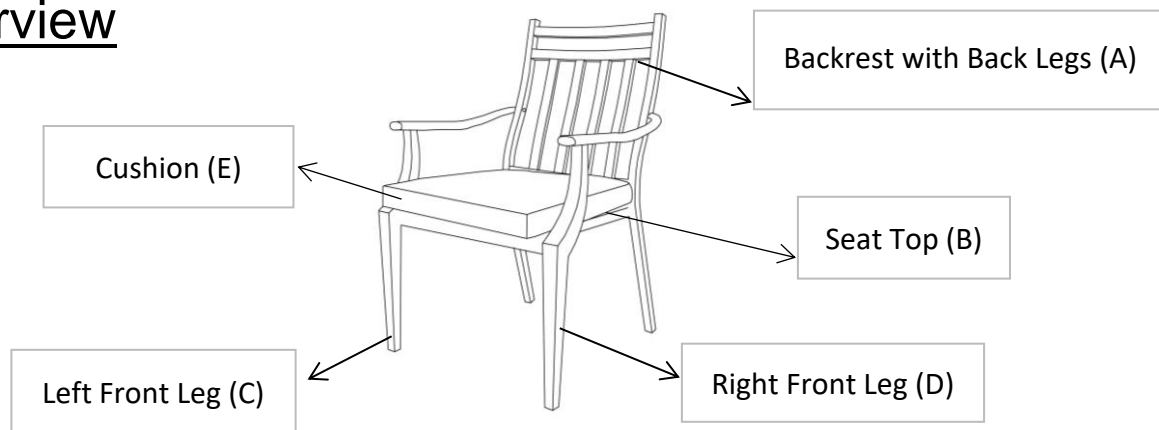

This Chair has multiple parts and may require up to 20 minutes to assemble. To give you an overview of the Chair parts, the above picture is to help you put the various parts into perspective. Please read through the instructions below to familiarise yourself with the parts and steps before assembly.

## Step 1

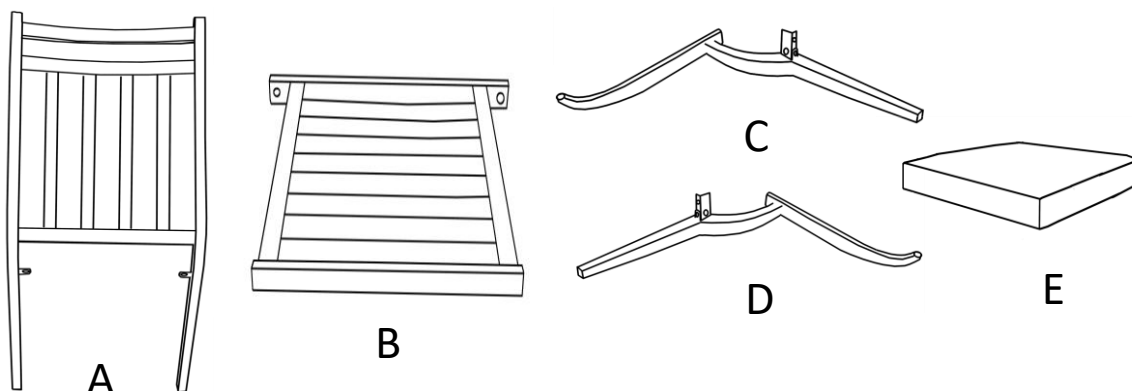

Unpack and place all parts on a clean, non-marring surface.

## Step 2

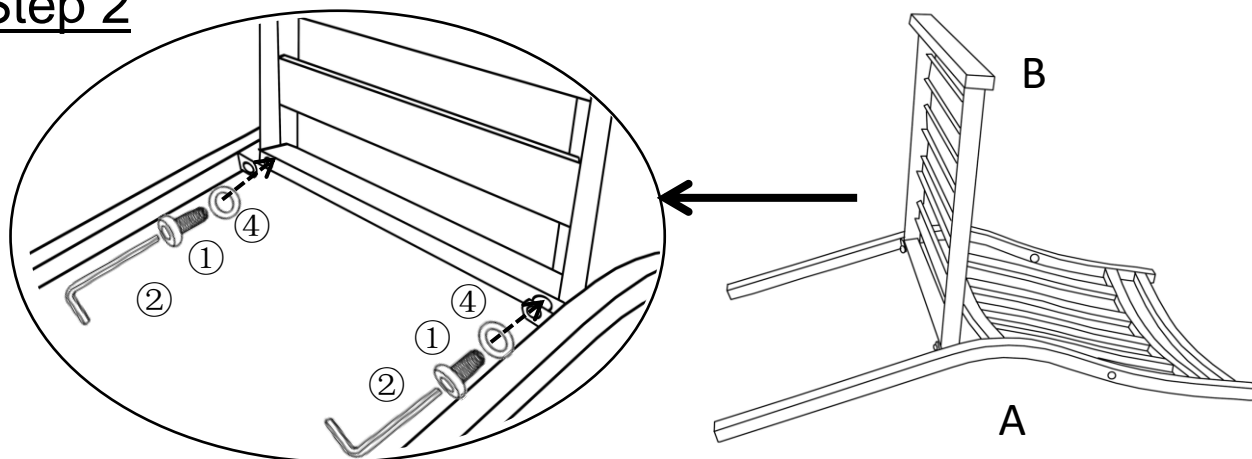

Lay the Backrest with Back Legs(A) facedown onto a clean, non-marring surface.

Attach Seat Top(B) to Backrest with Back Legs(A) using Bolts(①) and Washers(④) with Allen Key(②).

**Do not fully tighten the Bolts.**

### Step 3

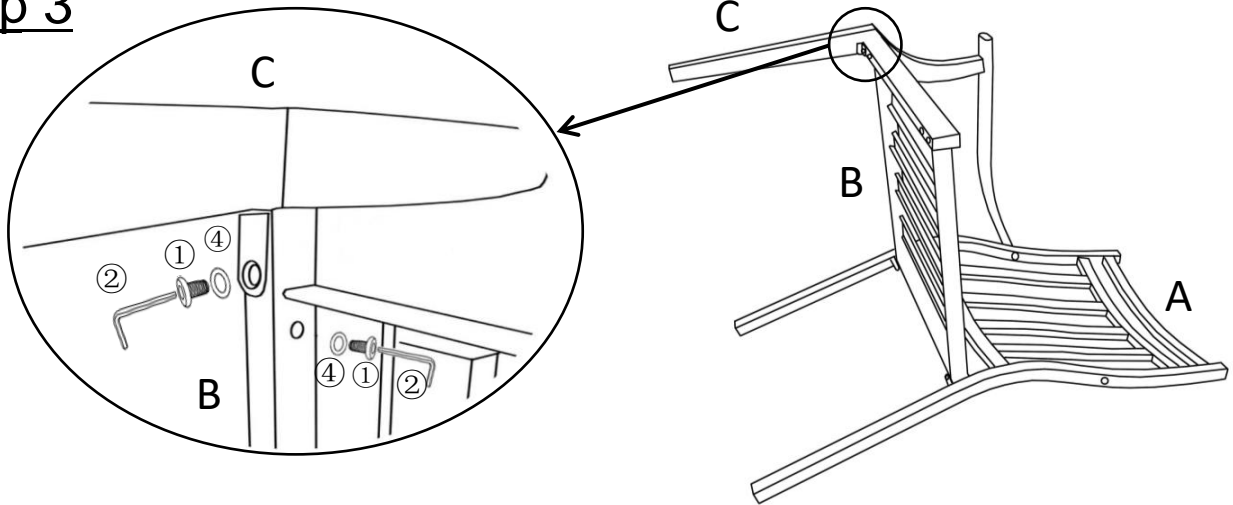

Attach the Left Front Leg(C) to Seat Top(B) using Bolts(①) and Washers(④) with Allen Key(②).

**Do not fully tighten the Bolts.**

### Step 4

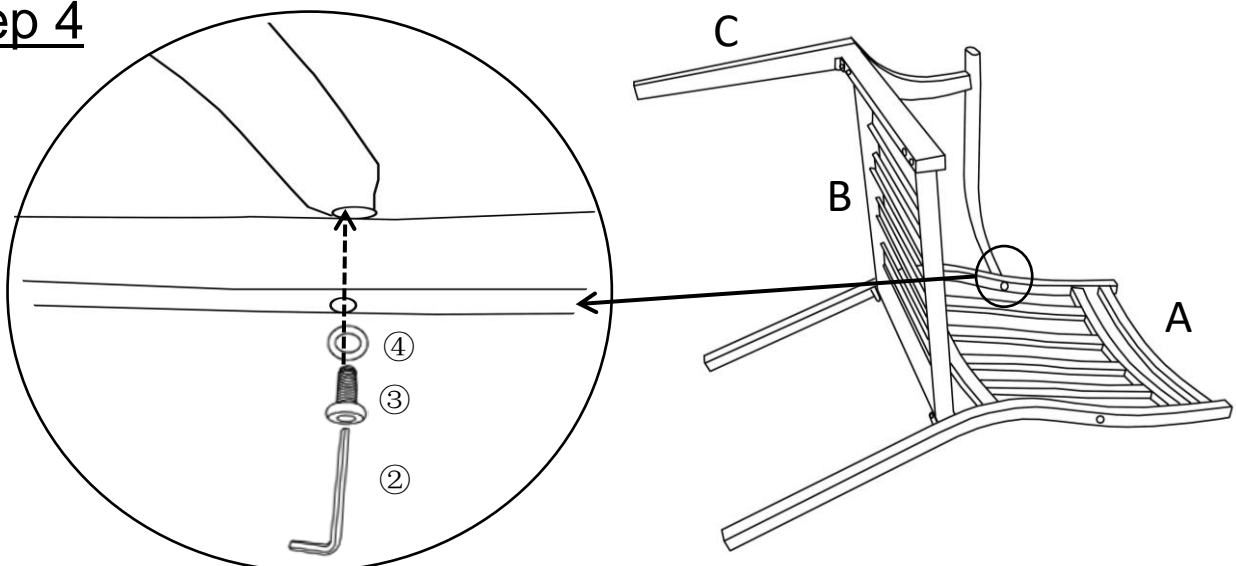

Attach the Left Front Leg(C) to Backrest with Back Legs(B) using Bolt(③) and Washer(④) with Allen Key(②).

**Do not fully tighten the Bolt.**

## Step 5

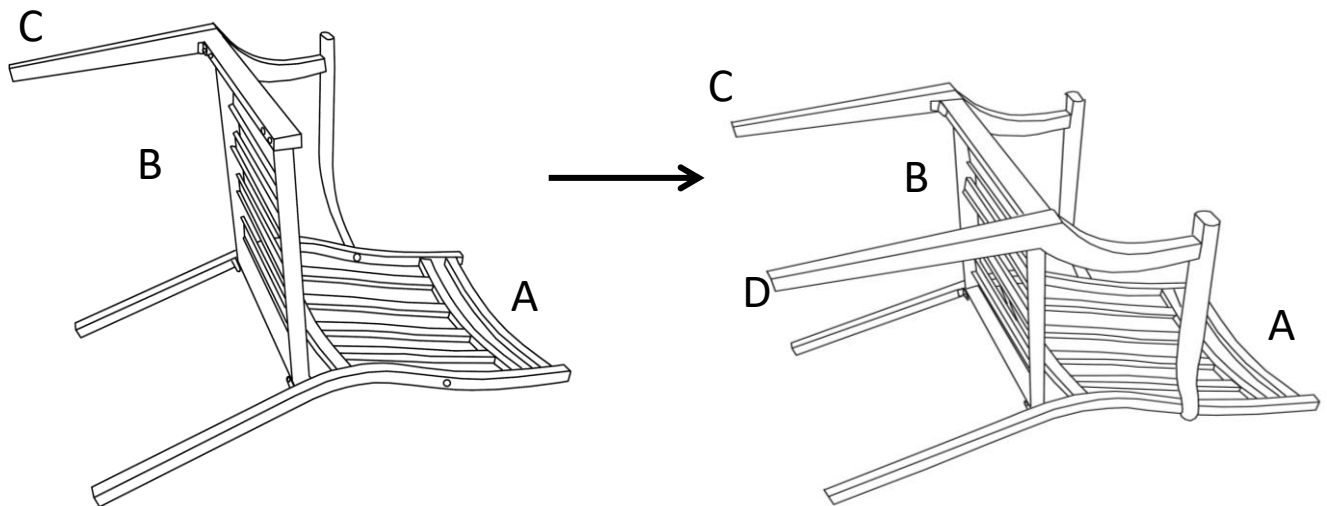

Repeat Step 3 & Step 4 to assemble Right Front Leg(D).

## Step 6

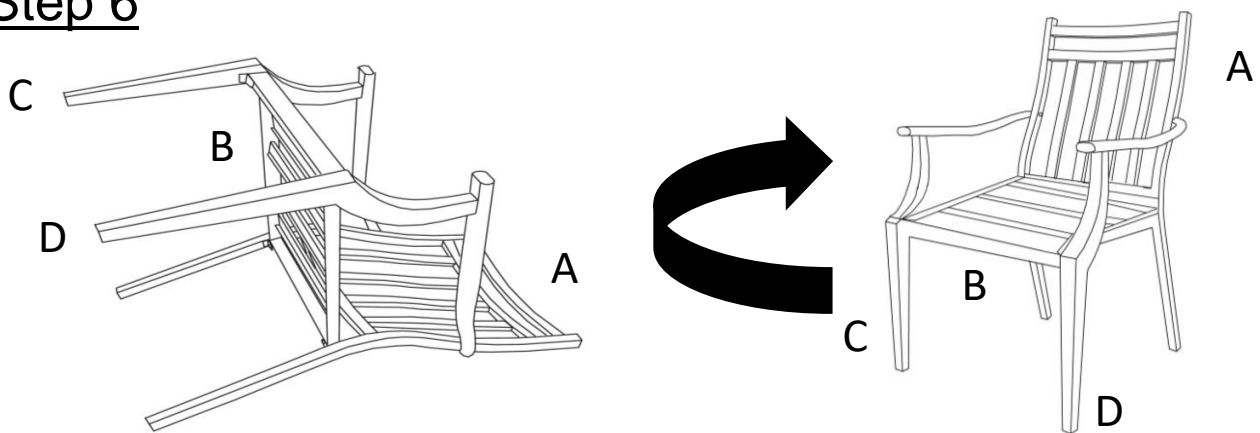

Stand the Chair up.

Carefully sit onto the Chair.

This pressure will help align all parts at all joints.

**In a sequential manner, tighten all Bolts at all joints.**

## Step 7

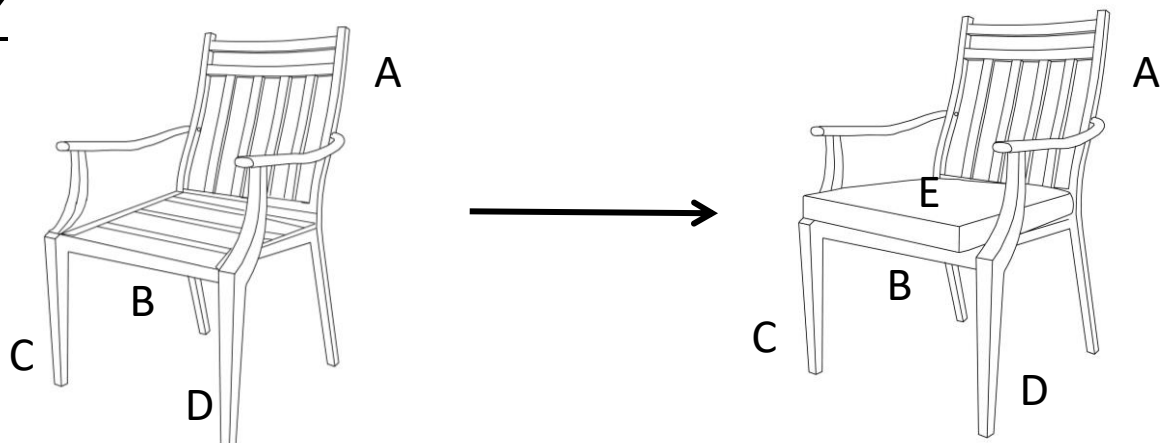



















Place the Seat Cushion(E) onto the Chair.

Your Chair is ready for use.

**This Chair can only be used on a flat, level surface.**

## Care & Maintenance

-   ● Do not put hot items directly on furniture surface
  -   ● Do not clean furniture with harsh cleansers or polish.
  -   ● To obtain the longest lifespan of your outdoor products, minimizing exposure to direct sunlight is recommended.
  -   ● Children should not climb or jump on the furniture.
  -   ● Do not write on furniture without a padded barrier to protect the surface.
  -   ● To obtain the longest lifespan of your outdoor products, avoid extended and lengthy exposure to rain, snow, and direct sunshine. Whenever possible cover the product and /or place under patio or awnings.
  -   ● Not for commercial use. For residential use only .
  -   ● Stains may be removed with mild soap solution and damp cloth.
- 
-   ● Dust and pick-up spills using a clean, non-colored, lint-free cloth .