

ASSEMBLY INSTRUCTIONS CHAIR

IMPORTANT NOTE:

Please read and follow the Assembly Instructions carefully.

- Identify and separate all parts before discarding packaging.
- Place wooden parts on clean soft surface to avoid scratching.
- Do not completely tighten screws until, after final assembly.
- Do not use a power tool for assembly.
- As with all assembled furniture, occasionally check to insure hardware is tight.

TOOL REQUIRED (NOT PROVIDED) PHILIPS SCREWDRIVER

NO	PART LIST	QTY
1	CHAIR BACK	1PC
2	FRONT LEG	1PC
3	WOODEN SEAT	1PC
4	SIDE RAIL (L/R)	2PCS
6	SIDE LOWER RAIL (L/R)	2PCS

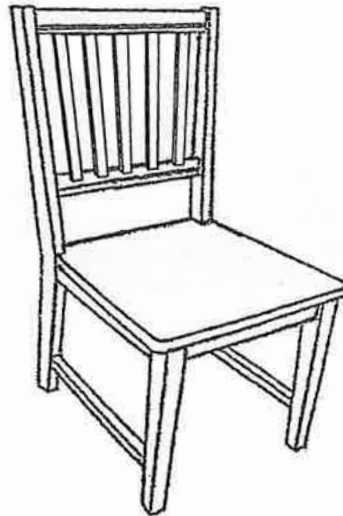

NO	HARDWARE LIST	QTY
A	JCBC BOLT M6 x 50mm 	4 PCS
B	SPRING WASHER M6 	4 PCS
C	FLAT WASHER M6 	4 PCS
D	CSK SCREW M4 x 32mm 	7 PCS
E	ALLEN KEY M4 	1PC
F	WOOD DOWEL M8 x 30mm 	16 PCS

Thank you for purchasing our product!

STEP 1

LOOSELY ATTACH (L/R) SIDE RAIL TO FRONT LEG USING BOLT (A) SPRING WASHER (B) AND FLAT WASHER (C).

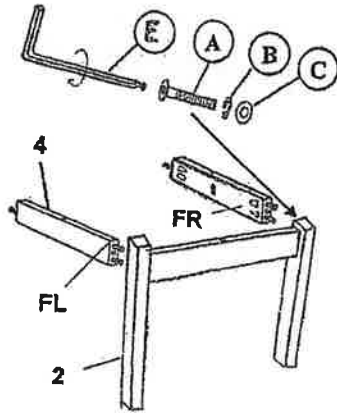

STEP 2

LAY CHAIR BACK OF FLAT SURFACE AND LOOSELY ATTACH (L/R) SIDE RAIL TO CHAIR BACK USING BOLT (A), SPRING WASHER (B) AND FLAT WASHER (C).

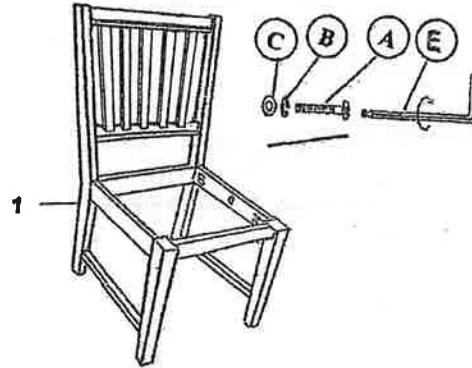

STEP 3

PLACE TWO STRETCHER(L/R) IN THE HOLES IN CHAIR BACK ALIGN AND FRAME UP CHAIR USING HAND PRESSURE TO GET STRETCHER(L/R) IN PLACE. COMPLETELY TIGHTEN ALL SCREWS.

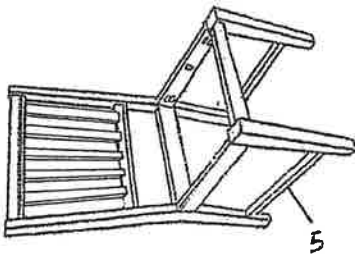

STEP 4

TURN STRETCHER(L/R) SO THE PREDRILLED HOLES FACE DOWNWARD AND SECURE USING 38mm SCREWS(D). ATTACH WOODEN SEAT USING 32mm SCREW(E).

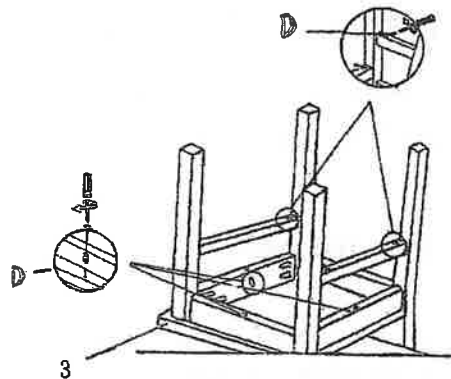

There are no pre-drilled holes to attach the seat