

# OFFICE CHAIR

---

Before you start, here are some helpful advice:

1. We suggest you spend a short time reading through this leaflet and then follow the simple step-by-step instructions.
2. Owing to the size and weight of the office chair, we recommend that it is assembled by two adults, on a carpeted or padded area, in the room that it is intended for. Approximate assembly time: 30 minutes.
3. Please do not use any tools other than those provided or recommended in these instructions.
4. Please do not throw away any of the packaging or the instruction until you have checked all the components and hardware and the furniture is fully assembled. Please ensure that the packaging is disposed of in a safe and environmentally friendly way.
5. Assemble all components loosely until advised to tighten. Depending on use, it may be necessary to tighten the components from time to time, so please save the tools that have been provided.
6. Please keep all pieces out of reach of children.



## Hardware:

A.  Bolt M6x45mm x4

B.  Flat Washer x4

C.  Allen Wrench x1

## Components:

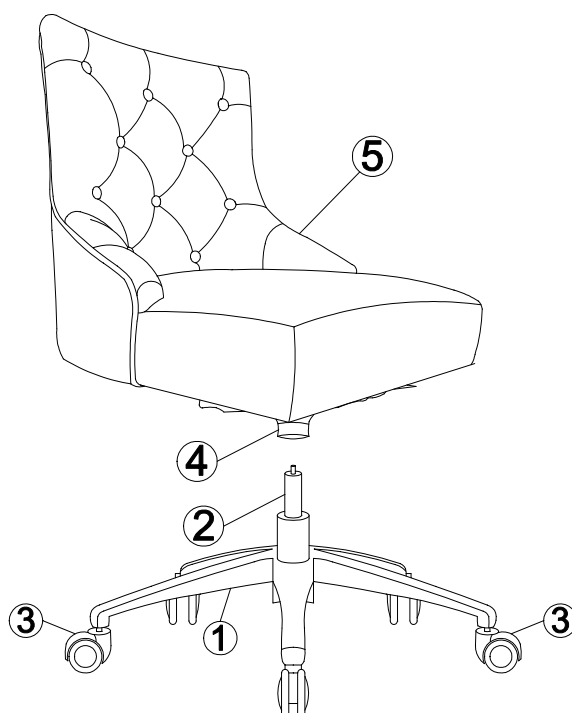

1. Base x1

2. Cylinder Column x1

3. Castor x5

4. Control Mechanism x1

5. Top x1

# OFFICE CHAIR

## STEP 1:

1. Please put **Base (1)** on a carpeted or padded surface.
2. Insert 1 piece of **Castor (3)** into the **Base (1)** as shown by hand.
3. Repeat the same steps for the remaining 4 pieces of **Castors (3)**.
4. Carefully turn over the assembled **Base (1)** and Insert the **Cylinder Column (2)** as shown.

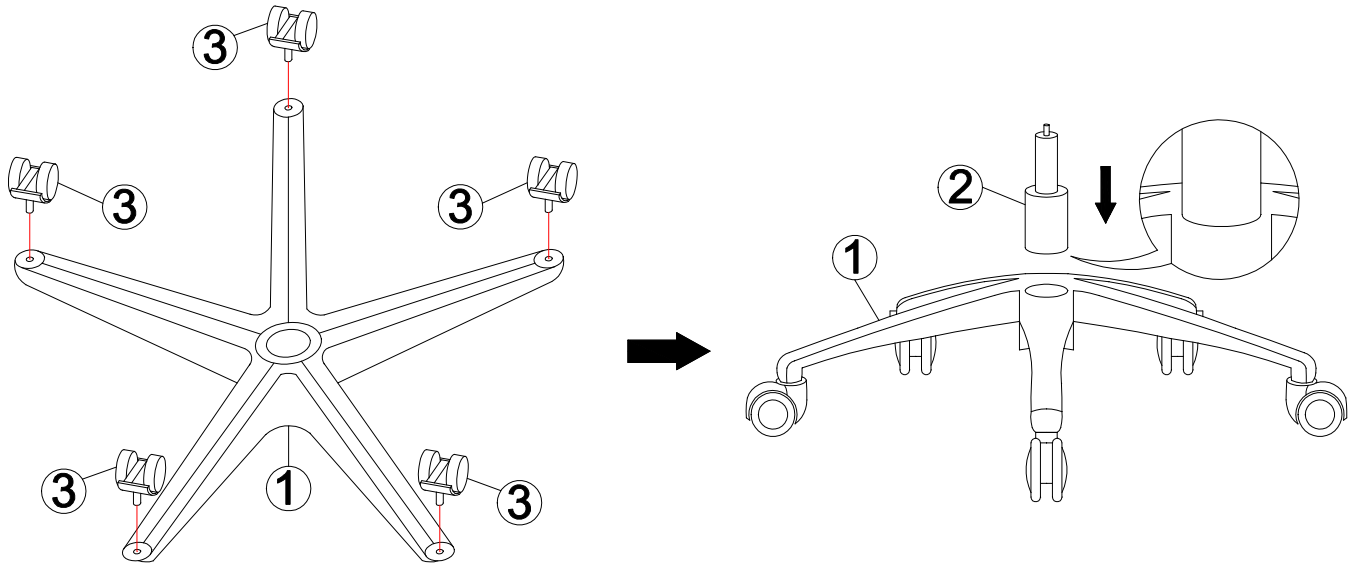

## STEP 2:

1. Please put **Top (5)** upside down on a carpeted or padded surface.
2. Attach **Control Mechanism (4)** to the **Top (5)** by using 4 pieces of **Bolts (A)** and 4 pieces of **Flat Washer (B)** as shown and use **Allen Wrench (C)** to tighten all **Bolts (A)** clockwise as shown.

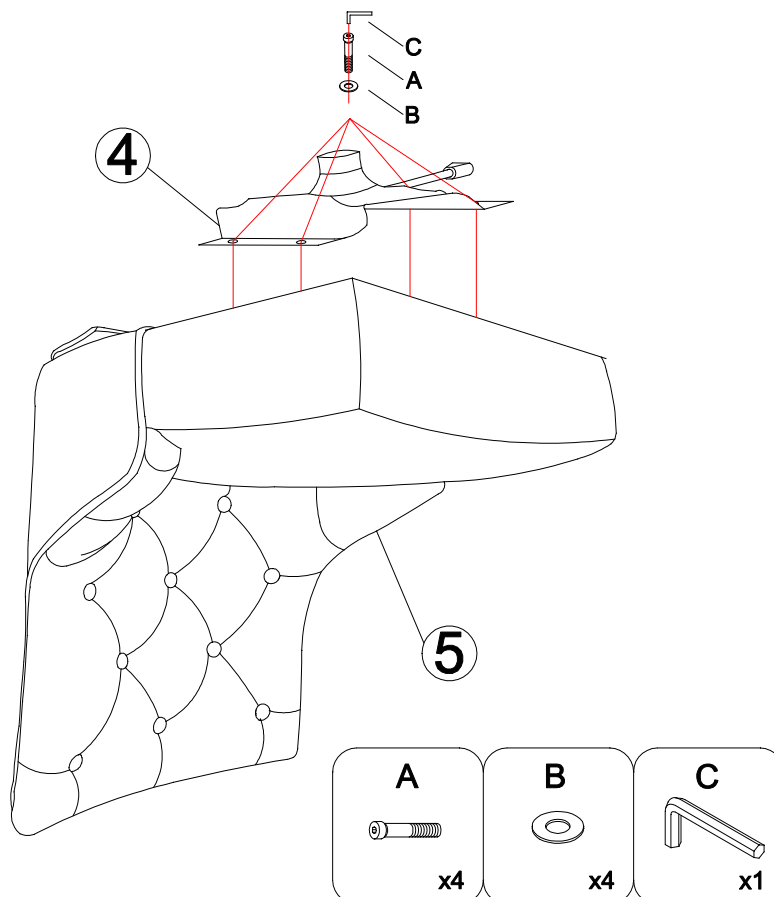

Hardware & Tools Required

# OFFICE CHAIR

---

## STEP 3:

Insert **Control Mechanism (4)** into the **Cylinder Column (2)** as shown.

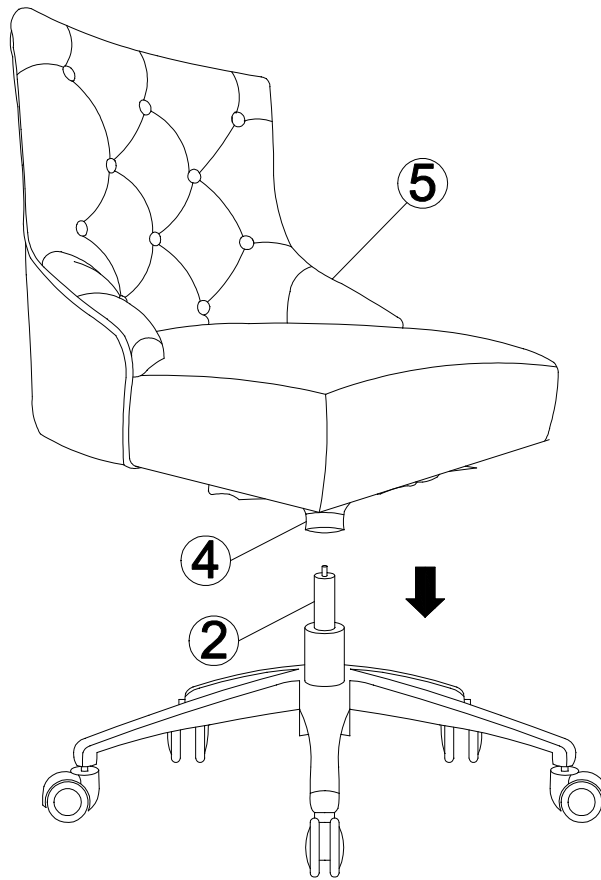

### Attention:

When you use the handle to adjust the height to be lower, please move away your feet from the base at the same time.

Your office chair is ready to be used now!