

ASSEMBLY INSTRUCTION

Computer Desk

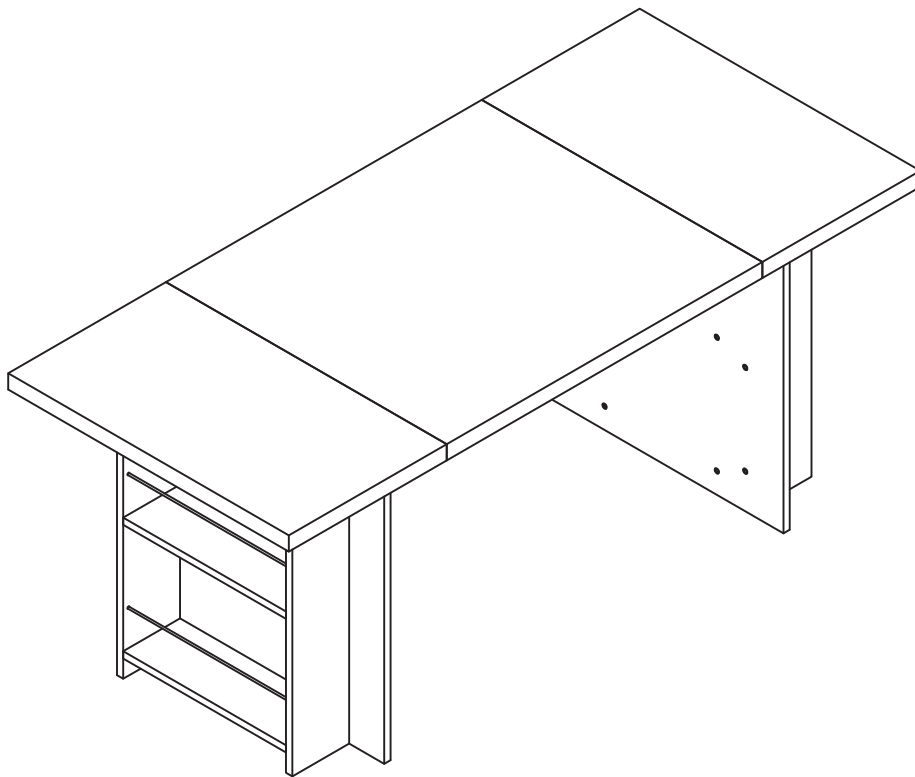

ASSEMBLY TIPS

1. Please read the assembly instructions first and become familiar with the parts.
2. Proper assembly of this item requires 2 people.

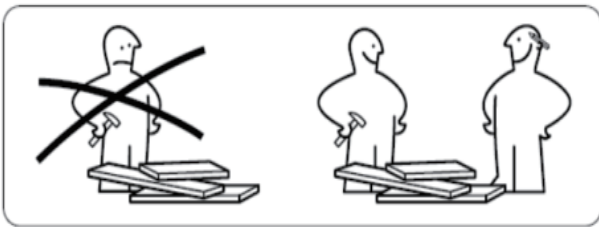

3. Unpack and assemble this unit in an spacious area, assemble the unit on top of the empty carton or carpet to prevent scratches.

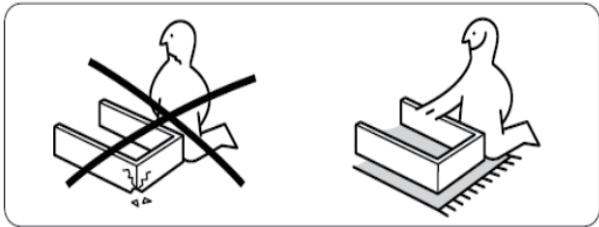

4. To avoid accidentally discarding small parts or hardware, DO NOT dispose of any contents until assembly is completed.
5. **Do not fully tighten all bolts until all parts are in place.** Failure to follow these instructions may cause the bolts to misalign during assembly.





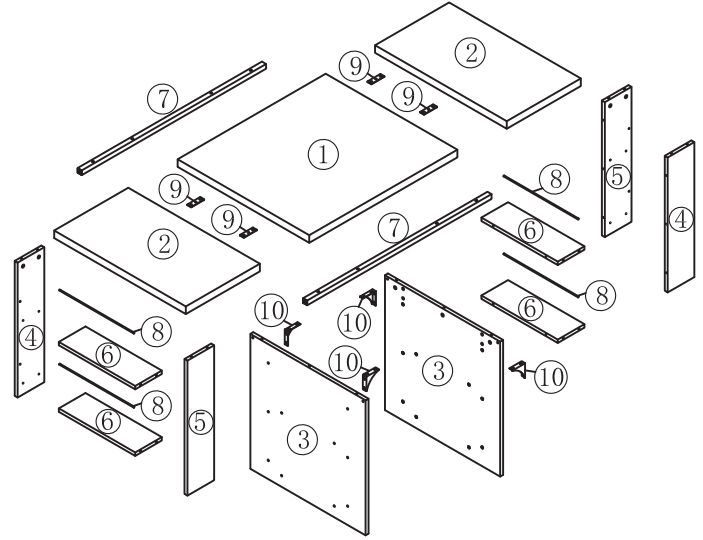
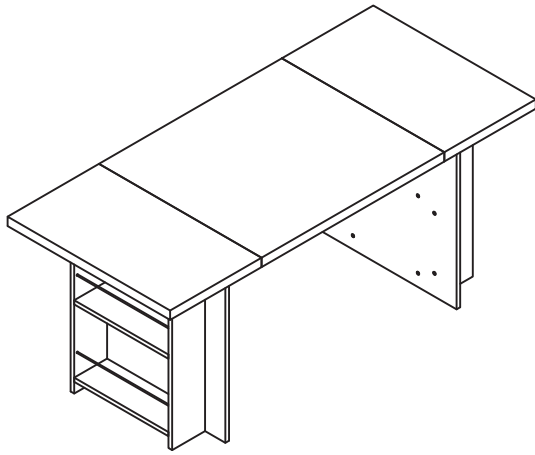

CARE INSTRUCTIONS

- (1) Hardware may loosen overtime. Periodically check that all connections are tight.
- (2) Wipe with a soft, dry cloth. To protect finish, avoid the use of chemicals and household cleaners.
- (3) All hot serving dishes should be placed on a pad.
- (4) Any liquid spilled onto the furniture should be cleaned up immediately with a dry cloth.

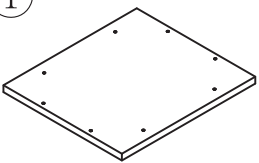
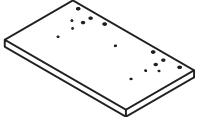
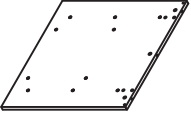
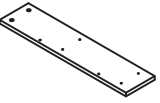
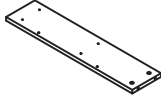
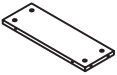
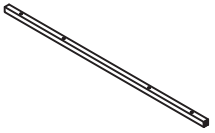
Part Identification

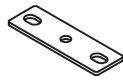
While not all parts are labeled, some of the parts will have a label to help distinguish similar parts from each other. Use this part identification to help identify similar parts.

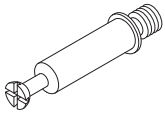
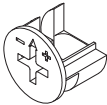
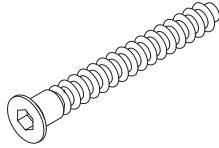
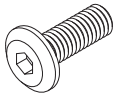
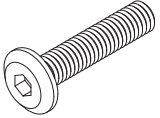

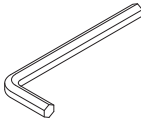
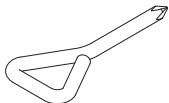
 1 Middle Desktop 1 pc	 2 Side Desktop 2 pcs	 3 Side Panel 2 pcs	 4 Vertical Panel 2 pcs	 5 Vertical Panel 2 pcs			
 6 Side Shelf 4 pcs	 7 Support Bar 2 pcs	 8 Support Rod 4 pcs	 9 Flat Bracket 4 pcs	 10 Angle Bracket 4 pcs			
A  Cam Bolt Ø6*45mm 30 pcs		B  Cam Lock Ø15*11.5mm 30 pcs		C  Self-tapping Screw M7*50mm 20 pcs		D  Short Bolt M6*15mm 24 pcs	
E  Long Bolt M6*40mm 12 pcs		F  Anti-skid Pad 30*15*5mm 12 pcs		G  Allen Key 4mm 1 pc		H  Phillips Screwdriver 70*30*5mm 1 pc	

Hardware Usage Guide

HOW TO USE A CAM BOLT & CAM LOCK.

1.



Cam Bolt

Clockwise rotate the CAM BOLT until the shoulder is against the surface of the board.

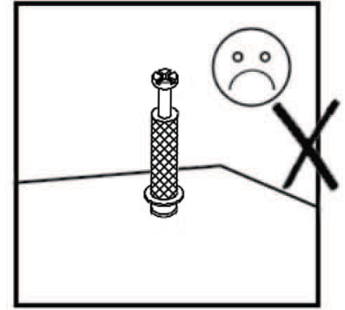
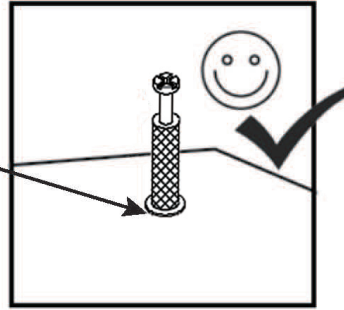

2.

Arrow



Cam Lock

Push a CAM LOCK into the board. The arrow in the CAM LOCK must point toward the hole in the edge of the board.

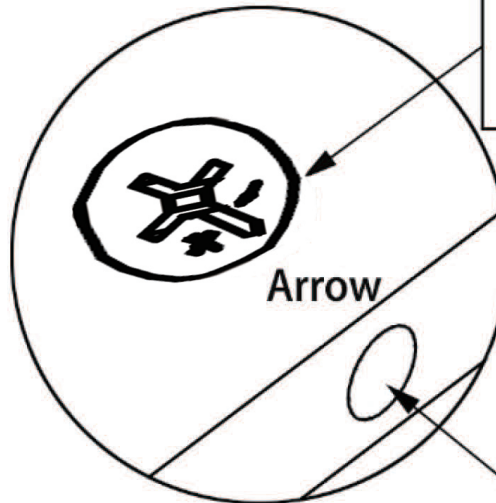

Hole

3.

Insert the CAM BOLT into the CAM LOCK. Clockwise rotate to tighten the CAM LOCK.

1

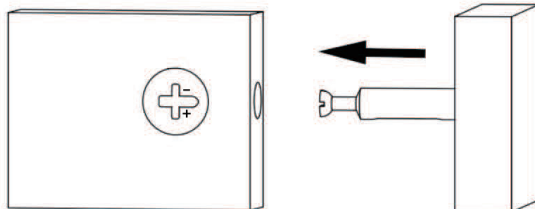

2

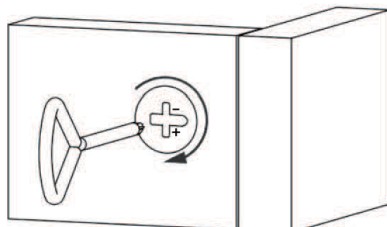

Step 01

NOTE: All bolts must be fully tightened at this step.

- 1.1 Lay the Vertical Panels (4) and (5) on a clean smooth surface such as carpet or cardboard. Insert and fasten 8 Cam Bolts (A) into the holes on the Vertical Panels (4) and (5) by Phillips Screwdriver (H) until the shoulder is against the surface of the board. Repeat the same steps for the other set of Vertical Panels (4) and (5). Fully tighten all bolts at this step.
- 1.2 Attach two Side Shelves (6) to the Vertical Panel (4). Make sure the Cam Bolts (A) on the Vertical Panel (4) are inserted into two Side Shelves (6). Insert 4 Cam Locks (B) into two Side Shelves (6), make sure the arrow on Cam Lock (B) points to Cam Bolt (A), and then tightly fasten by turning Phillips Screwdriver (H) clockwise. Repeat the same steps for the other set of Vertical Panel (4) and two Side Shelves (6). Fully tighten all bolts at this step.

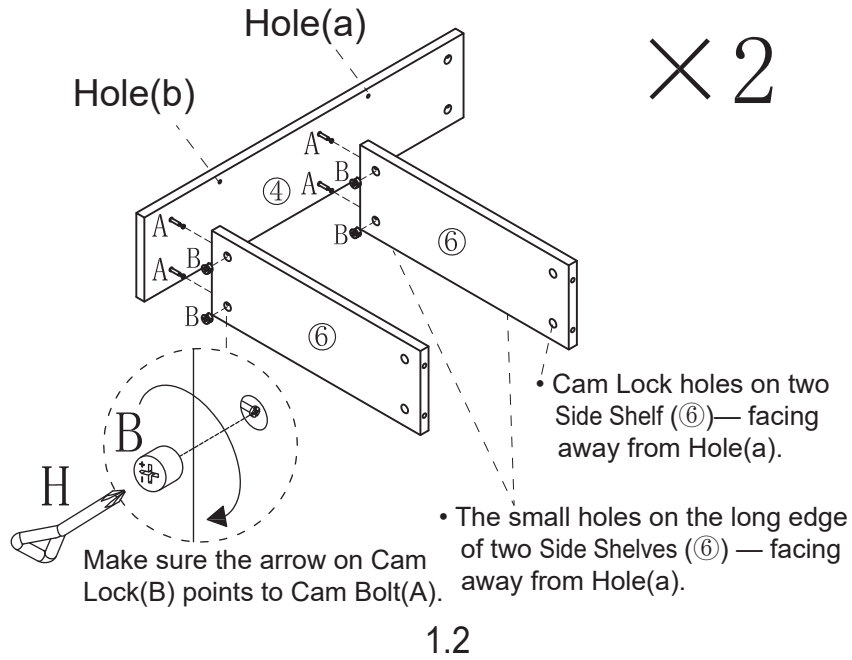
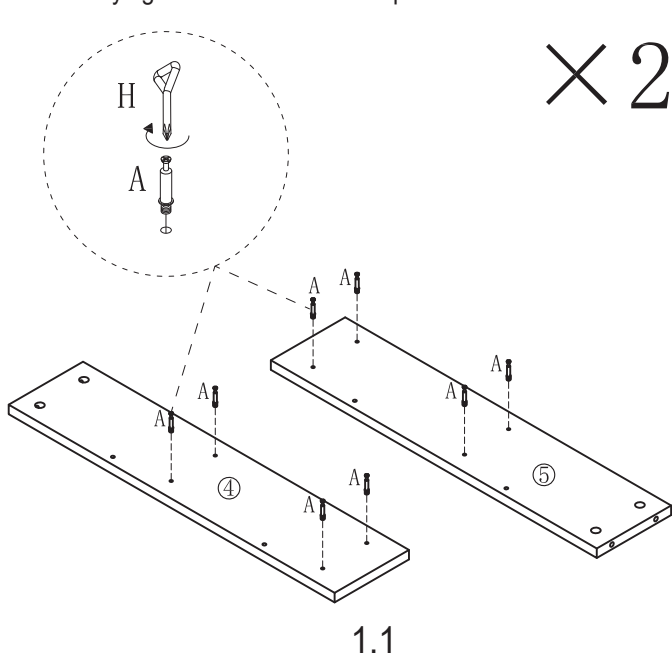

Step 02

NOTE: All bolts must be fully tightened at this step.

- 2.1 Insert 2 Support Rods (8) to the Vertical Panels (4) and (5). Attach and align the Vertical Panel (5) to two Side Shelves (6). Make sure the Cam Bolts (A) on the Vertical Panel (5) are inserted into two Side Shelves (6). Insert 4 Cam Locks (B) into two Side Shelves (6), make sure the arrow on Cam Lock (B) points to Cam Bolt (A) on the Vertical Panel (5), and then tightly fasten by turning Phillips Screwdriver (H) clockwise. All bolts must be fully tightened at this step. Repeat the same assembly for the other set.
- 2.2 Attach and fix the Side Panel (3) to the two Side Shelves (6), Vertical Panels (4) and (5) with 10 Self-tapping Screws (C) by Allen Key (G). Repeat the same assembly for the other set.

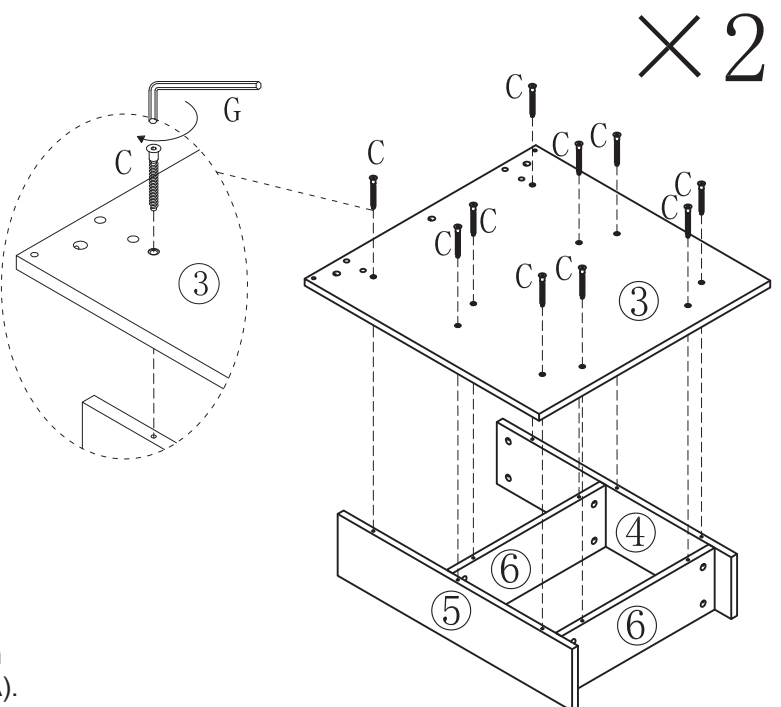
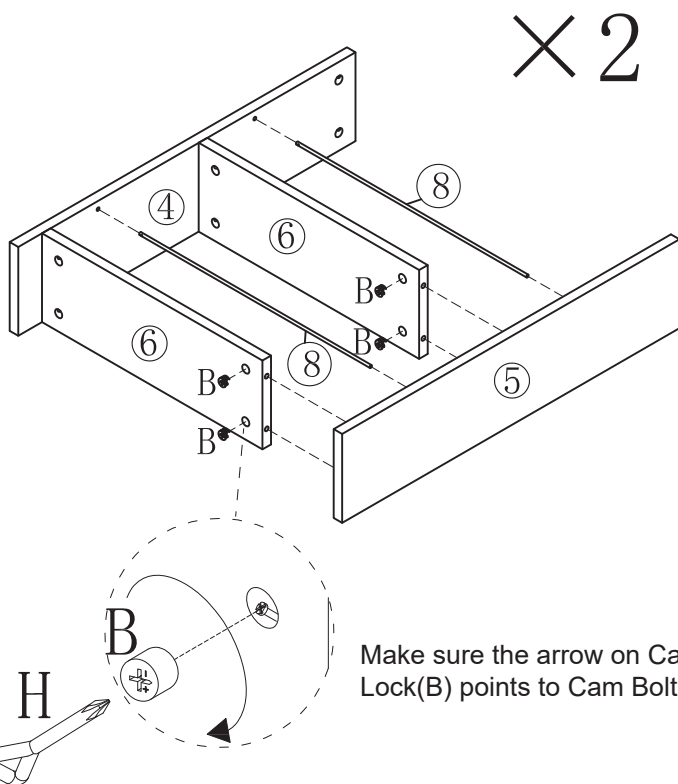

Step 03

- 3.1 Lay the Middle Desktop (①) and the two Side Desktops (②) face down. Fasten four Flat Brackets (⑨) on the bottom side between the Middle Desktop (①) and Side Desktop (②) with eight Short Bolts (D) by Allen Key (G). Insert and fasten 14 Cam Bolts (A) into the holes on the two Side Desktops (②) by Phillips Screwdriver (H) until the shoulder is against the surface of the board.
- 3.2 Fix two Support Bars (⑦) to the Desktop with eight Long Bolts (E) by Allen Key (G).
Please make sure to use the correct bolts to avoid damaging the desktop. Do not fully tighten all bolts at this step.

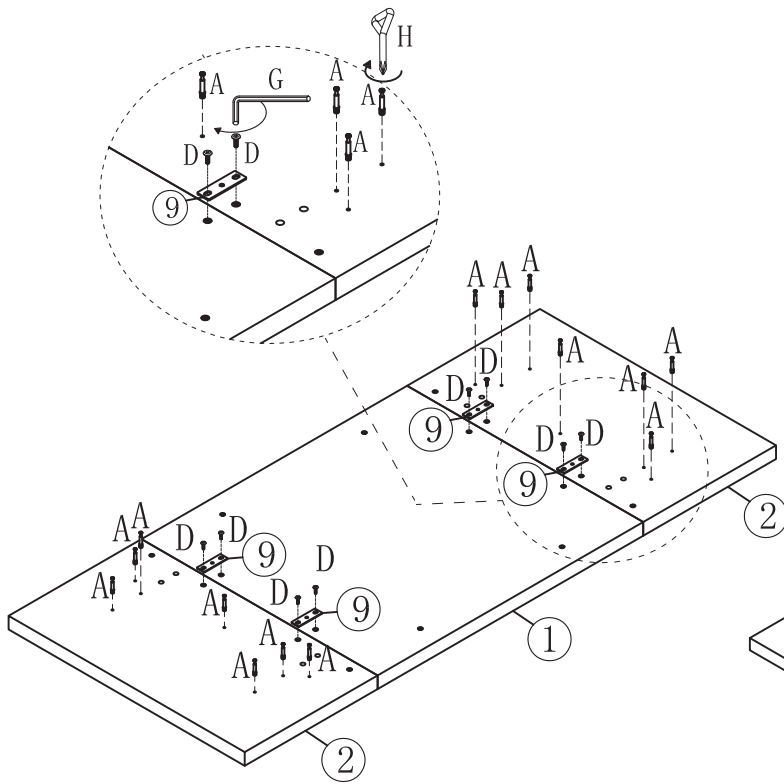

3.1

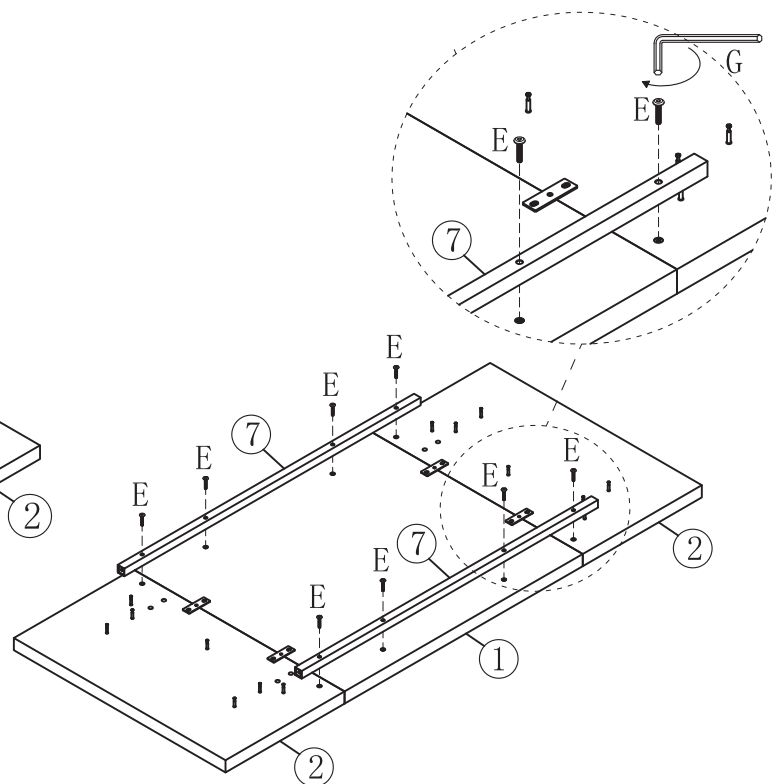

3.2

Step 04

NOTE: If holes don't align, loosen all bolts and adjust the holes slightly. After all holes are aligned, tighten all bolts.

- 4.1 Attach the Side Desktop (②) to the Side Panel (③), Vertical Panels (④) and (⑤). Make sure Cam Bolts (A) on the Side Desktop (②) are inserted into the Side Panel (③), Vertical Panels (④) and (⑤). Insert 3 Cam Locks (B) into the Side Panel (③), and Insert 2 Cam Locks (B) into each Vertical Panel (④) and (⑤), make sure the arrow on Cam Lock (B) points to Cam Bolt (A) on the Side Desktop (②), and then tightly fasten by turning Phillips Screwdriver (H) clockwise. If holes don't align, loosen all bolts and adjust the holes slightly. After all holes are aligned, tighten all bolts.
- 4.2 Repeat the same assembly for the other set.

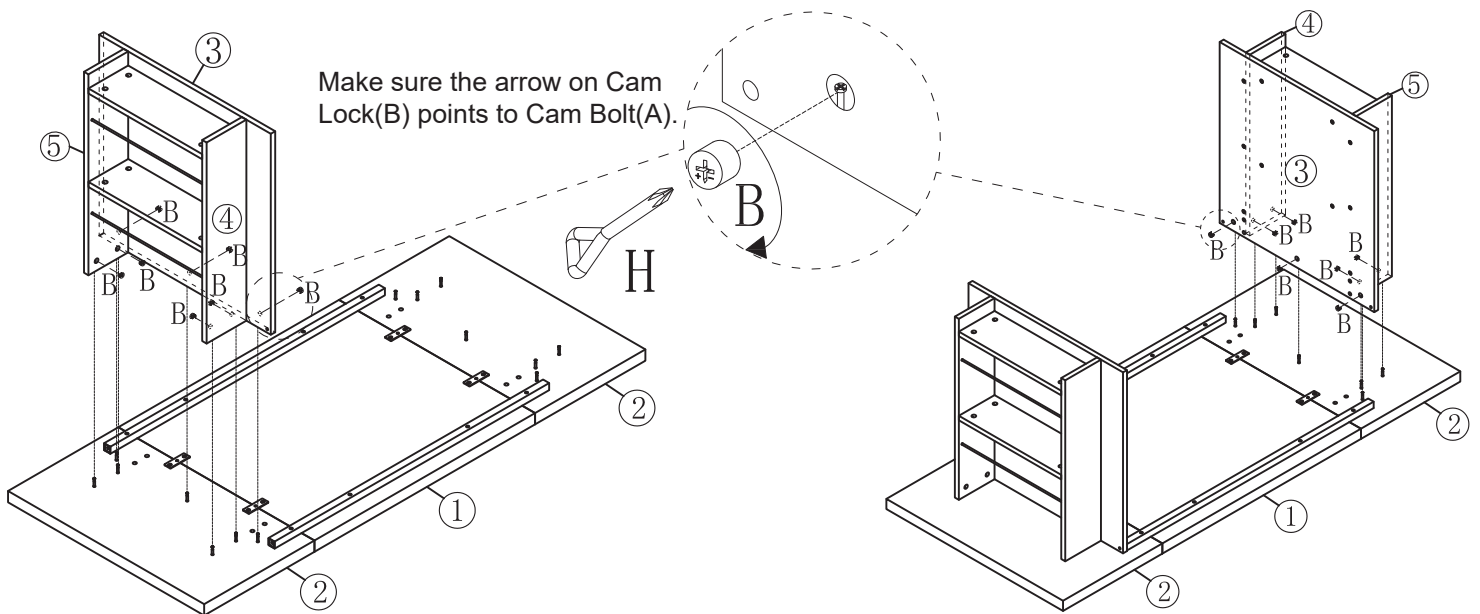

4.1

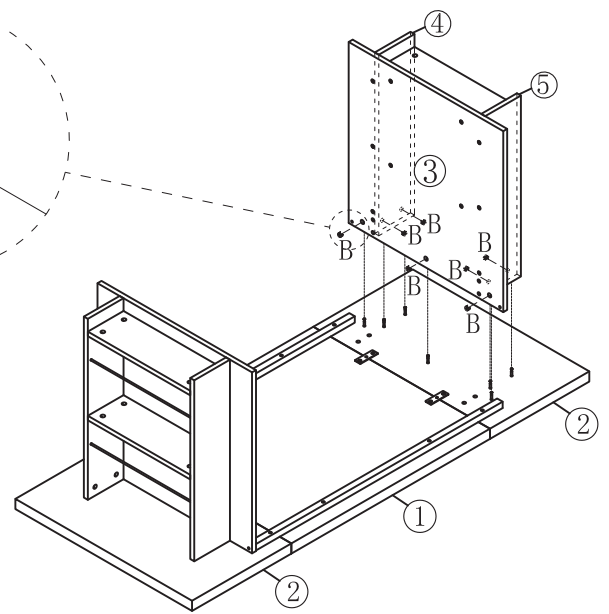

4.2

Step 05



5.1 Attach and align two Side Panels (3) to two Support Bars (7) with 4 Long Bolts (E) by Allen key (G).
Don't fully tighten all bolts at this step.

5.2 Fix 4 Angle Brackets (10) to the Side Desktops (2) and Side Panels (3) with 16 Short Bolts (D) by Allen Key (G). If holes don't align, loosen all bolts and adjust the holes slightly. After all holes are aligned, tighten all bolts.

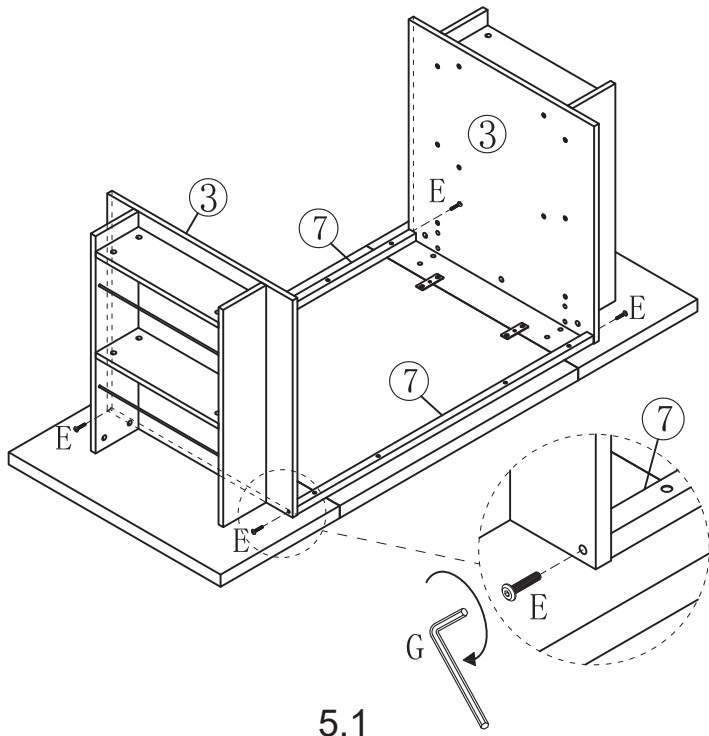

5.1

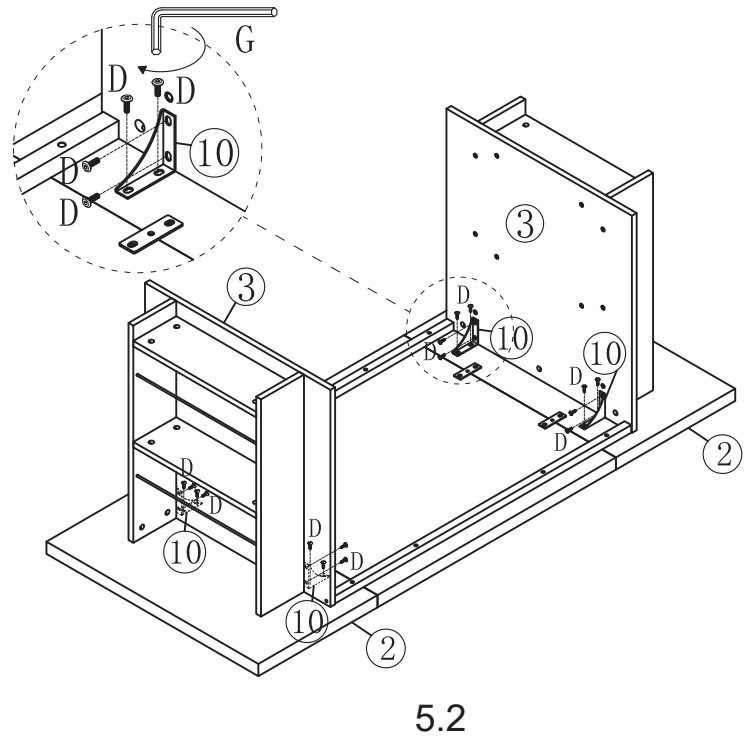

5.2

Step 06



6.1 Apply 12 Anti-skid Pads (F): 4 to the bottom of the each Side Panel (3) and 1 each to the outer bottom of the Vertical Panels (4) and (5), as shown. Press firmly to ensure proper adhesion.

6.2 Assembly completed. Ensure all bolts and screws are securely tightened and the desk is stable before use.

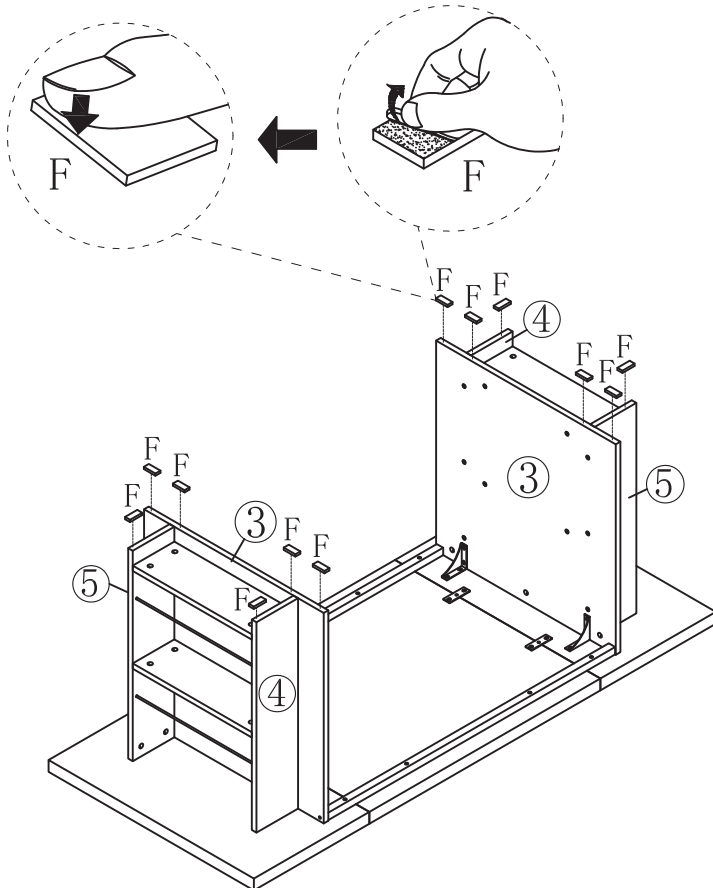

6.1

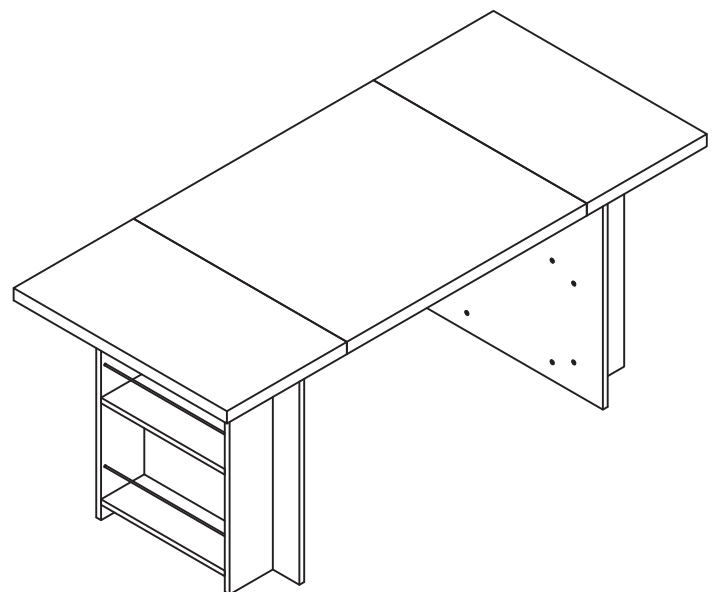

6.2

Gentle Reminder

⚠ Please don't install clamp-mounted monitors directly to the tabletop and use two padding boards to prevent surface damage.

