

Thank you for purchasing the **OFFICE CHAIR!**

Before you start, here are some helpful advice:

1. We suggest you spend a short time reading through this leaflet and then follow the simple step-by-step instructions.
2. Owing to the size and weight of the office chair, we recommend that it is assembled by two adults, on a carpeted or padded area, in the room that it is intended for. Approximate assembly time: 30 minutes.
3. Please do not use any tools other than those provided or recommended in these instructions.
4. Please do not throw away any of the packaging or the instruction until you have checked all the components and hardware and the furniture is fully assembled. Please ensure that the packaging is disposed of in a safe and environmentally friendly way.
5. Assemble all components loosely until advised to tighten. Depending on use, it may be necessary to tighten the components from time to time, so please save the tools that have been provided.
6. Please keep all pieces out of reach of children.

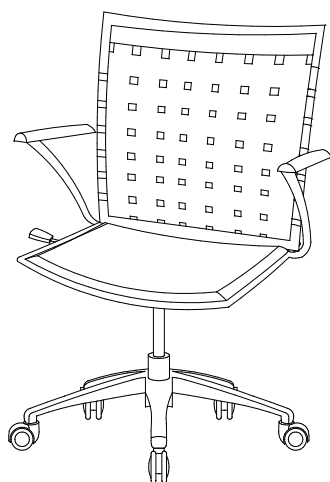

Hardware:

A.		Bolt M6x25mm	x2
B.		Bolt M6x20mm	x2
C.		Flat Washer	x4
D.		Allen Wrench	x1
E.		Nut M12	x2
F.		Spring Washer M12	x2
G.		Nut Driver	x1

Components:

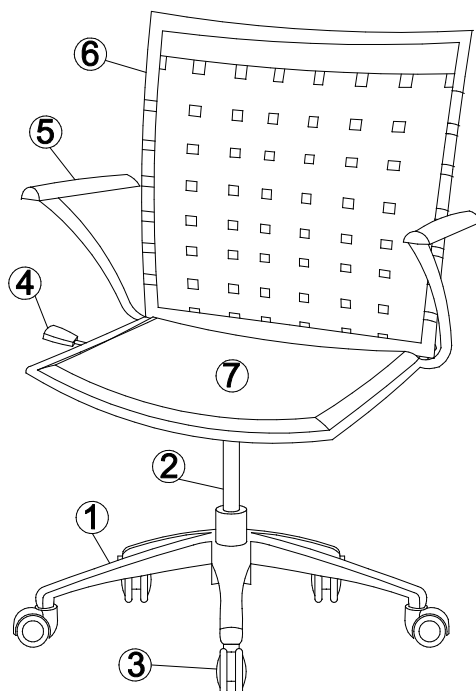

1. Base	x1	2. Gas Lift	x1	3. Castor	x5	4. Fixing Plate	x1
5. Seater Frame	x1	6. Backrest	x1	7. Seater	x1		

STEP 1:

1. Attach the **Backrest (6)** to the **Seater frame (5)** by using 2 pieces of **Nuts (E)** and 2 pieces of **Spring Washers (F)** as shown.
2. Use **Nut Driver (G)** to tighten all **Nuts (E)** clockwise as shown.

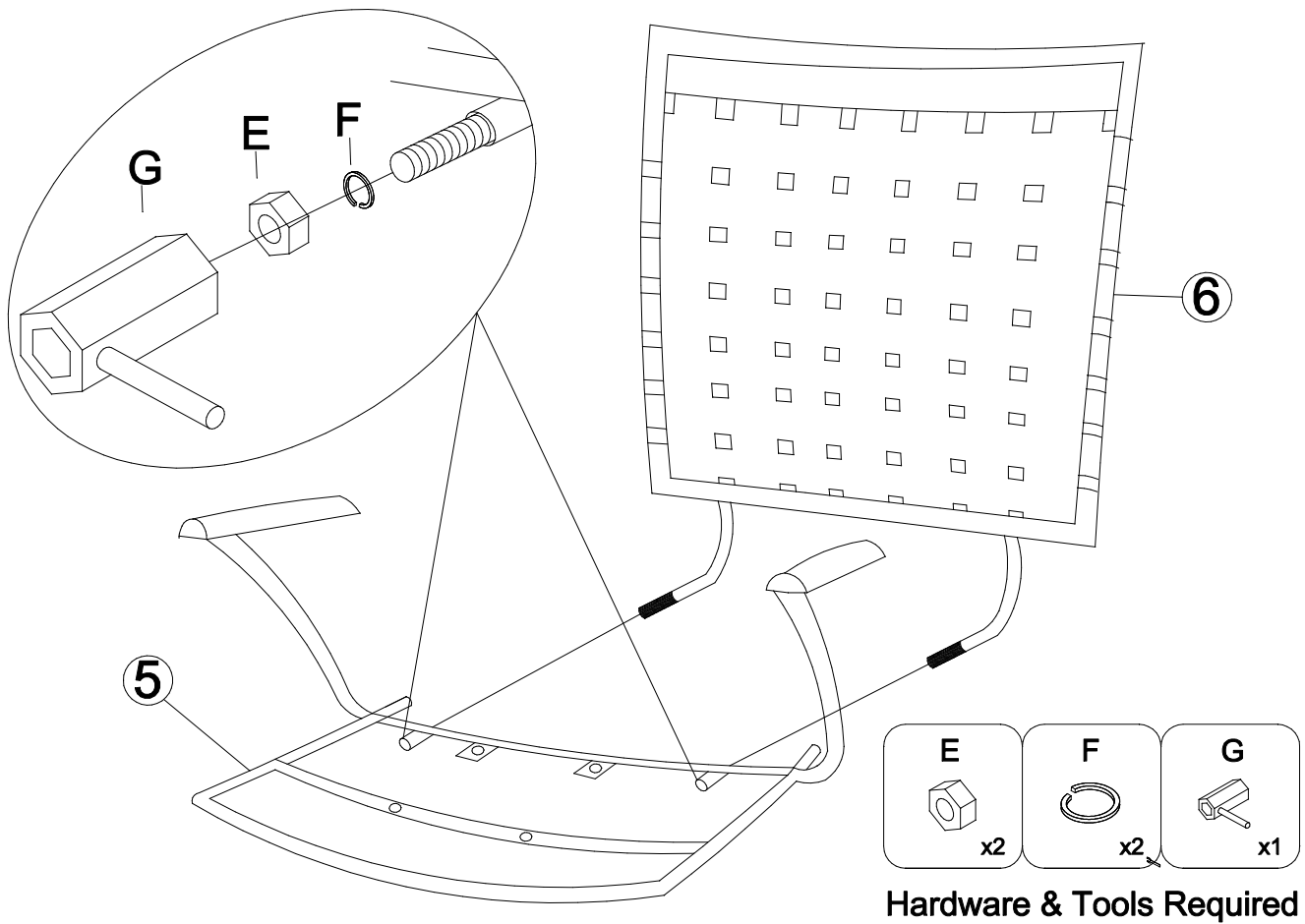

STEP 2:

1. Put the **Seater (7)** on the the **Seater Frame (5)** as shown.
2. Carefully turn over the assembled **Seater Frame (5)** and make sure the holes of the **Seater (7)** are aligned with the holes of the **Seater Frame (5)** as shown.

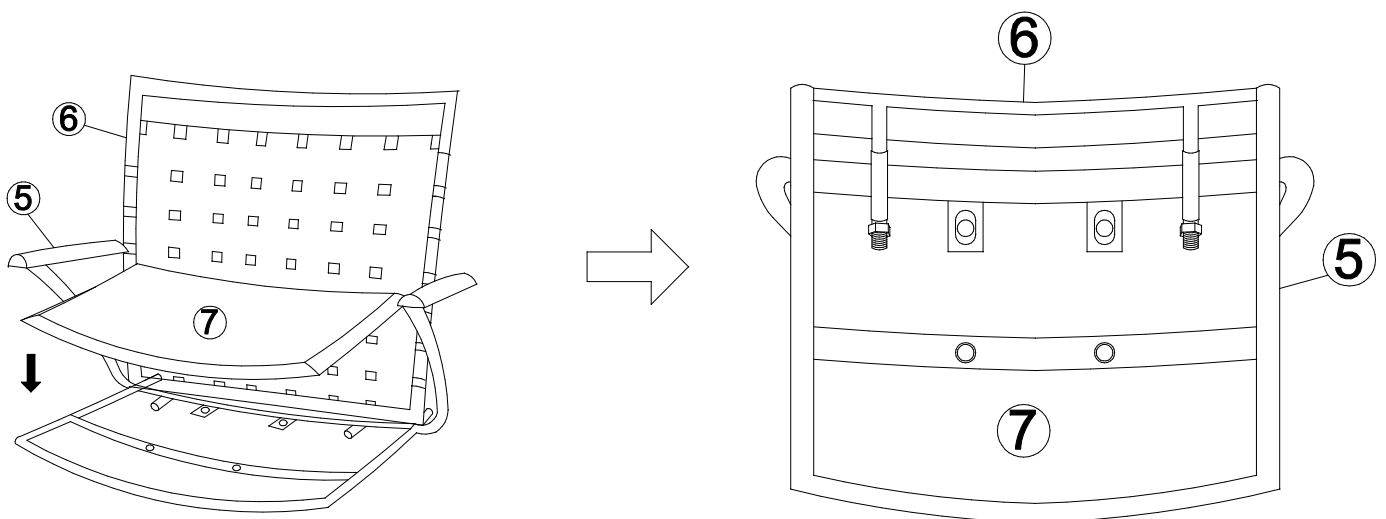

STEP 3:

1. Attach the **Fixing Plate (4)** to the **Seater frame (5)** and the **Seater (7)** by using 2 pieces of **Bolts(A)** and 2 pieces of **Flat Washers (C)** for front as shown.
2. Attach the **Fixing Plate (4)** to the **Seater frame (5)** and the **Seater (7)** by using 2 pieces of **Bolts(B)** and 2 pieces of **Flat Washers (C)** for back as shown.
3. Use **Allen Wrench (D)** to tighten all **Bolts (A)** and **Bolts (B)** clockwise as shown.

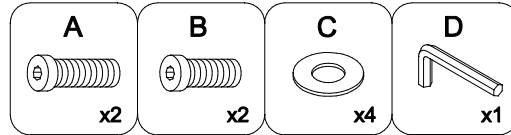
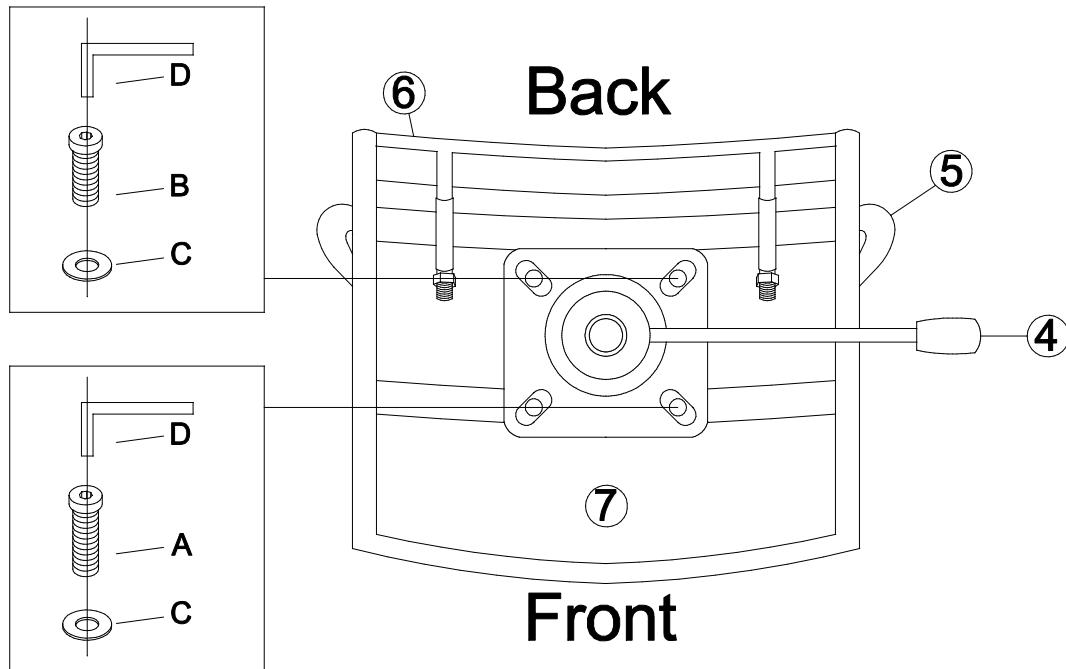

Hardware & Tools Required

STEP 4:

1. Please put **Base (1)** on a carpeted or padded surface.
2. Insert 1 piece of **Castor (3)** into the **Base (1)** as shown by hand.
3. Repeat the same steps for the remaining 4 pieces of **Castors (3)**.
4. Carefully turn over the assembled **Base (1)** and Insert the **Gas Lift (2)** as shown.

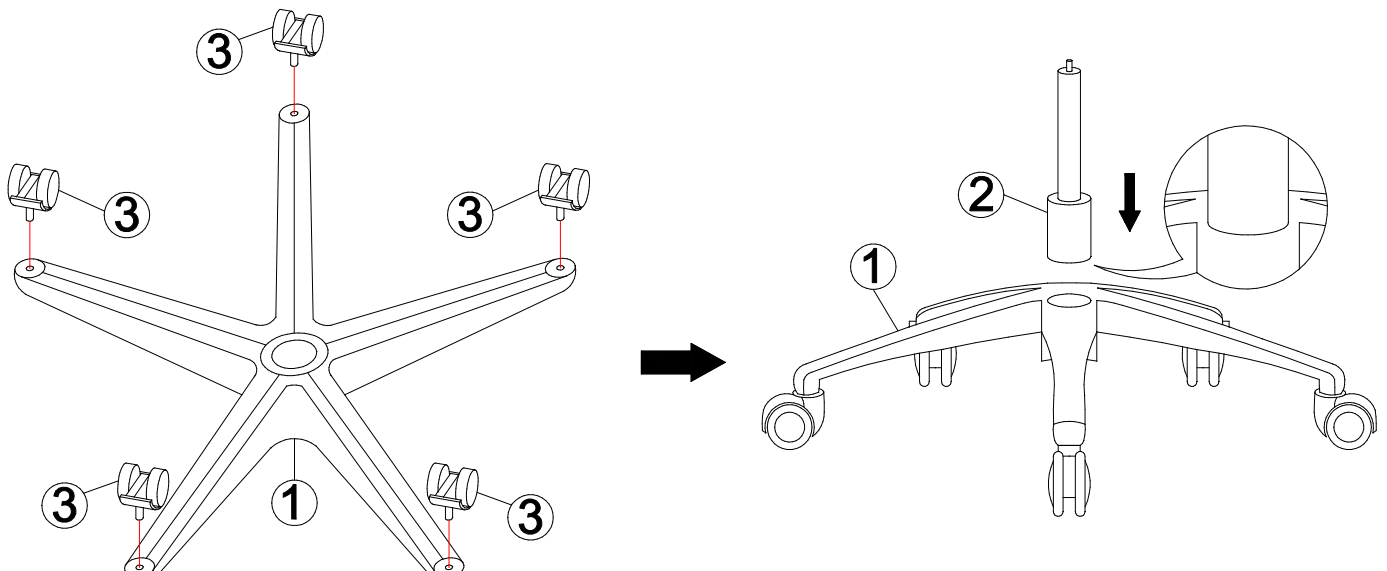

STEP 5:

Insert **Fixing Plate (4)** into the **Gas Lift (2)** as shown.

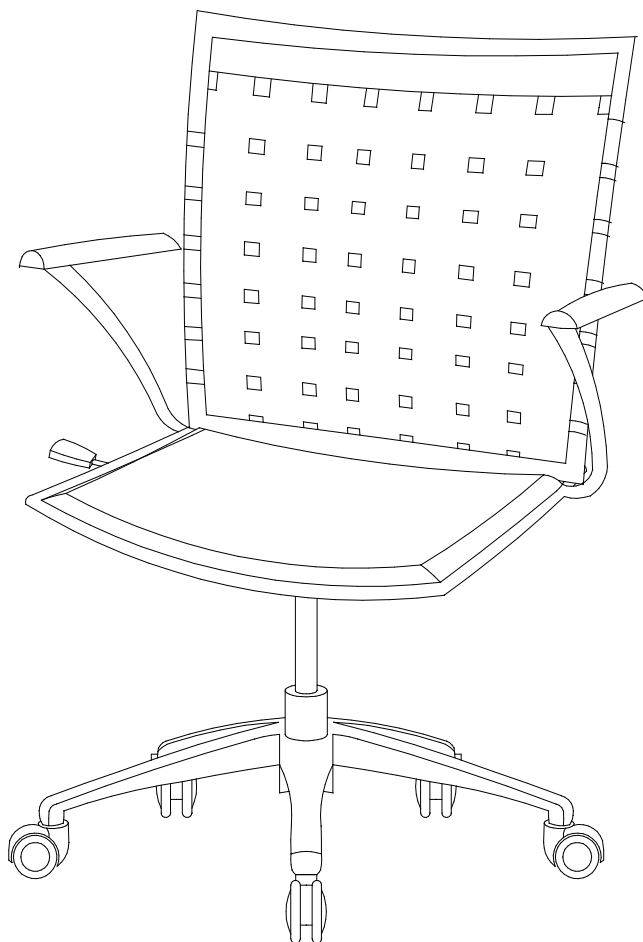
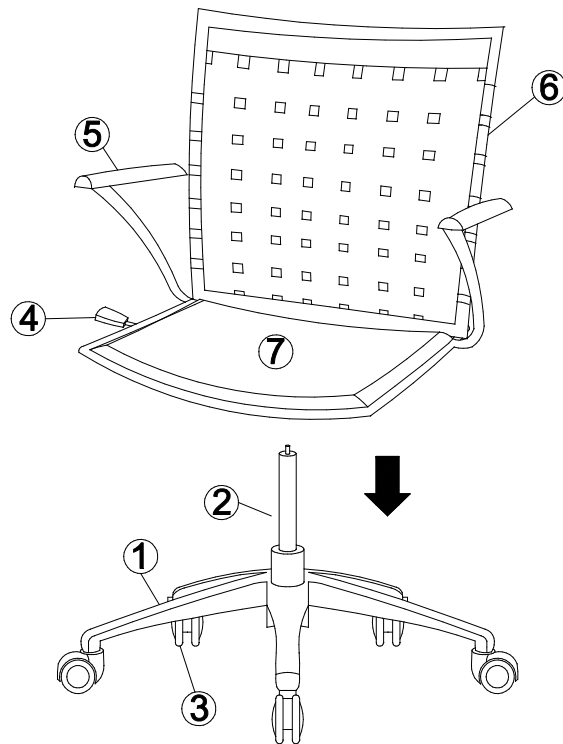

Attention:

When you use the handle to adjust the height to be lower, please move away your feet from the base at the same time.

Your office chair is ready to be used now!