

Assembly Instructions

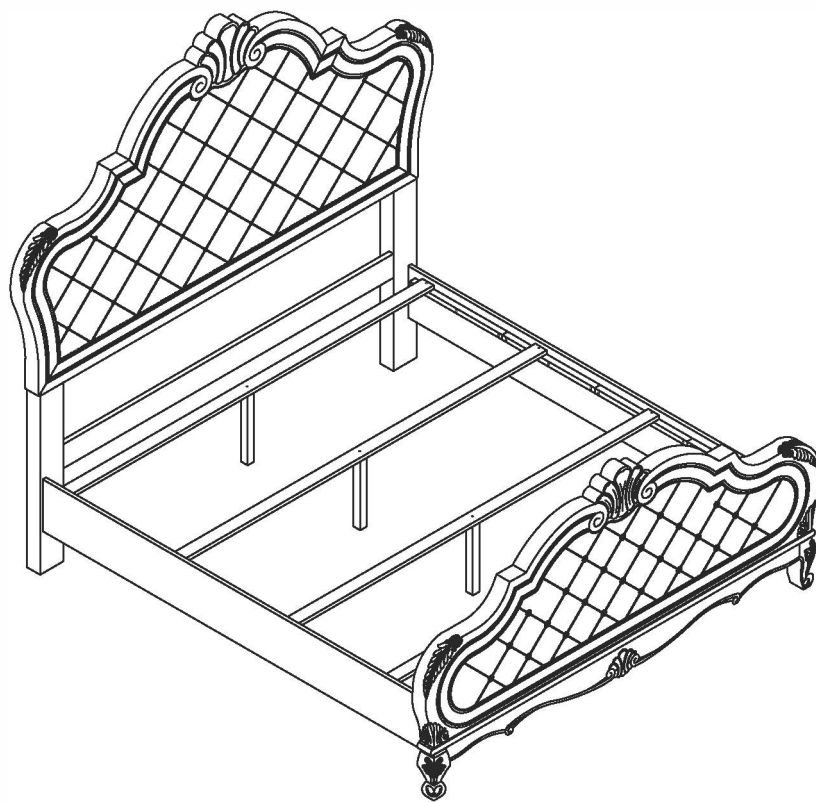

ASSEMBLY RATING

The Assembly Rating is a 5-point system that shows the degree of effort needed in assembling a specific product (with 1 being easy and 5 being difficult). For some products, two persons are recommended.

EASY  DIFFICULT

Tools Required For Assembly:

Allen Wrench



(Included)

Phillips Screwdriver



(Not Included)



2 PERSONS RECOMMENDED

ASSEMBLY & CARE ADVICE

FOR YOUR FURNITURE TO LAST, CORRECT ASSEMBLY AND PROPER MAINTENANCE ARE NECESSARY. PLEASE FOLLOW THE INFORMATION PROVIDED BELOW TO FULLY ENJOY YOUR FURNITURE.

BASIC ASSEMBLY TECHNIQUES

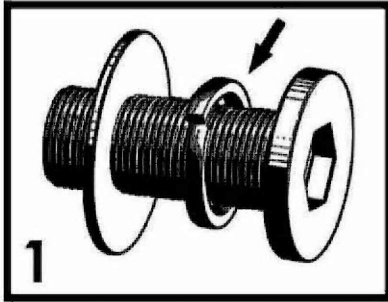

1
When lock or spring washer is used in an assembly, please make sure the lock or spring washer is placed between the larger flat washer and the head of the screw or bolt.

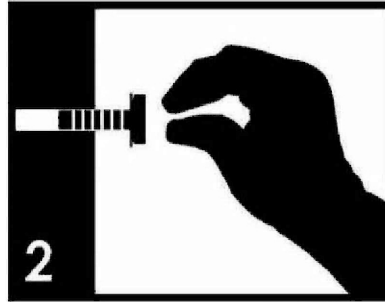

2
Position each part correctly and insert screws or bolts into their respective holes by hand tighten or using the proper hand tool. Only tighten when step is completed or when instructed to do so.

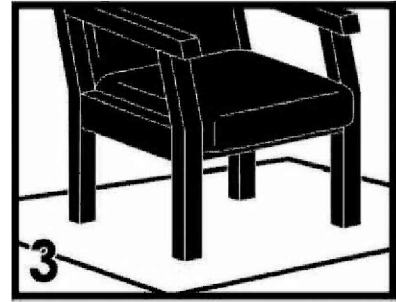

3
Use cardboard or carpet area when assembling furniture to prevent scratches. Make sure the furniture rests on a flat and level surface with each leg evenly touching the floor. No dragging of products/parts.

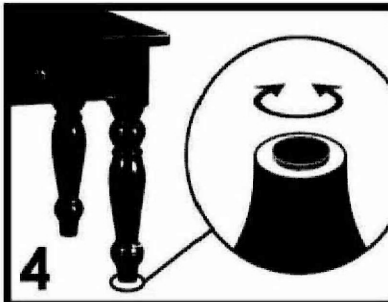

4
Some furniture comes with height adjustment knobs underneath each leg. To lower or to raise each leg, you need to turn clockwise or counterclockwise, respectively.

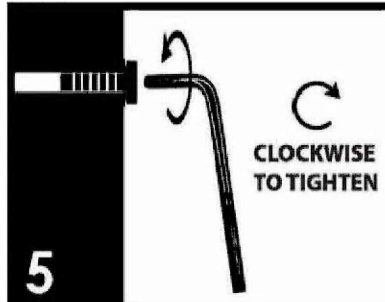

5
Make sure all parts are properly aligned, then use the appropriate hand tool to completely tighten the bolts or screws. Do not use power tools and do not overtighten.

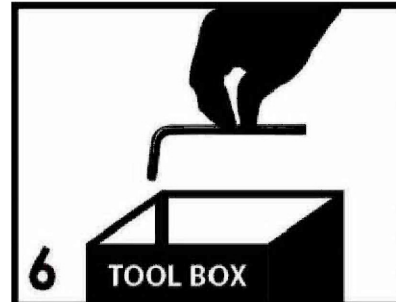

6
Save the instructions and store the Allen wrench or any supplied tool for later maintenance. After two weeks, check and tighten any loose hardware and repeat again every six months thereafter.

IT IS THE USER'S RESPONSIBILITY TO MAINTAIN THE FURNITURE. THE HARDWARE MAY LOOSEN OVER TIME AND MAY CAUSE THE FURNITURE TO BE WOBBLY AND UNABLE TO SUPPORT ITS INTENDED WEIGHT CAPACITY. THIS MAY LEAD TO COLLAPSE AND MAY CAUSE SERIOUS INJURY.



FAILURE TO FOLLOW THE GUIDELINES ABOVE MAY RESULT IN INJURY AND/OR PROPERTY DAMAGE.

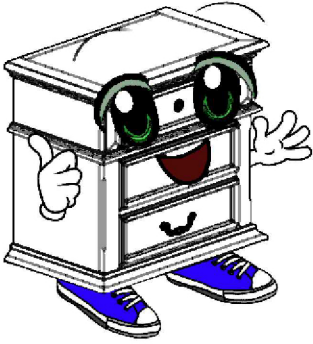











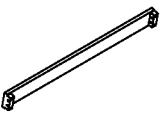

Before you begin, please read Page 2 of "Assembly and Care Advice".

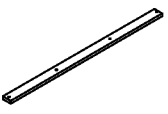
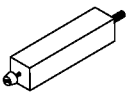
And remember, do not tighten until each step is completed or instructed.

Parts List

Hardware List

-  #1 x 1 pc
Headboard
-  #2 x 2 pcs
Headboard Leg (R&L)
-  #3 x 1 pc
Headboard Bottom Rail
-  #4 x 1 pc
Footboard
-  #5 x 2 pcs
Footboard Leg (R&L)
-  #6 x 2 pcs
Side Rail
-  #7 x 4 pcs
Slat
-  #8 x 4 pcs
Support Leg 35x35x337mm

-  #A x 16pcs
Bolt $\text{Ø}1/4"$ x 1-3/4"
-  #B x 16pcs
Lock Washer $\text{Ø}1/4"$ x 3/8"
-  #C x 16pcs
Flat Washer $\text{Ø}1/4"$ x 1/2"
-  #D x 12pcs
Bolt $\text{Ø}5/16"$ x 1"
-  #E x 3pcs
Allen Key M4
-  #F x 8pcs
Screw #4 x 30mm

Exploded View

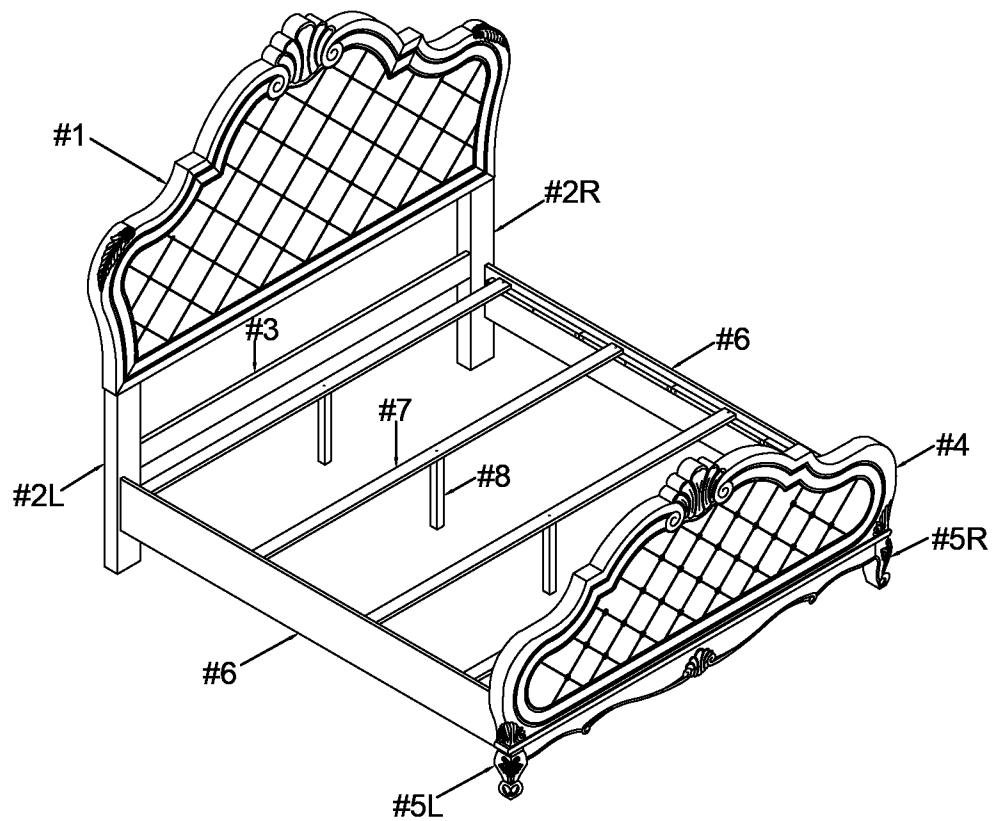

- #A x 12pcs
- #B x 12pcs
- #C x 12pcs

Align headboard legs (#2R/L) to the holes of the headboard (#1), then secure by using bolts (#A) with washers (#B,C).

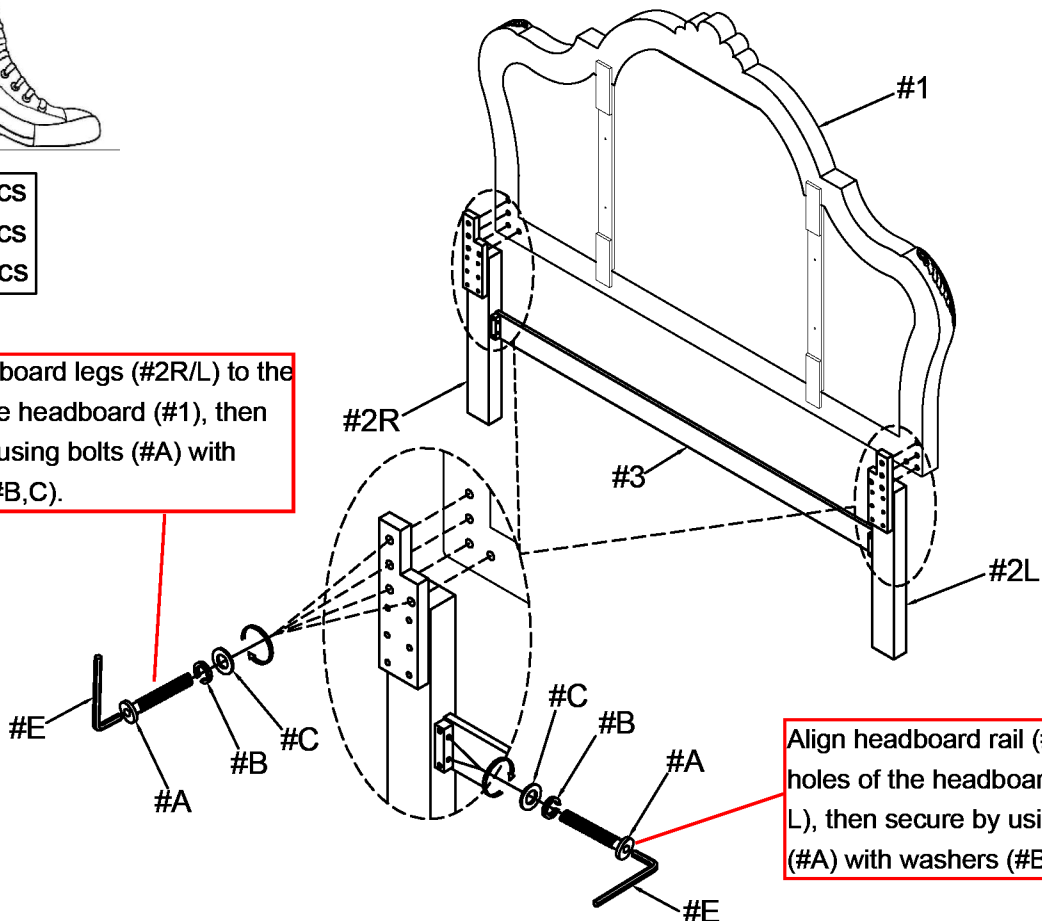

Align headboard rail (#3) to the holes of the headboard legs (#2R/L), then secure by using bolts (#A) with washers (#B,C).



#2

#A x 4pcs
#B x 4pcs
#C x 4pcs

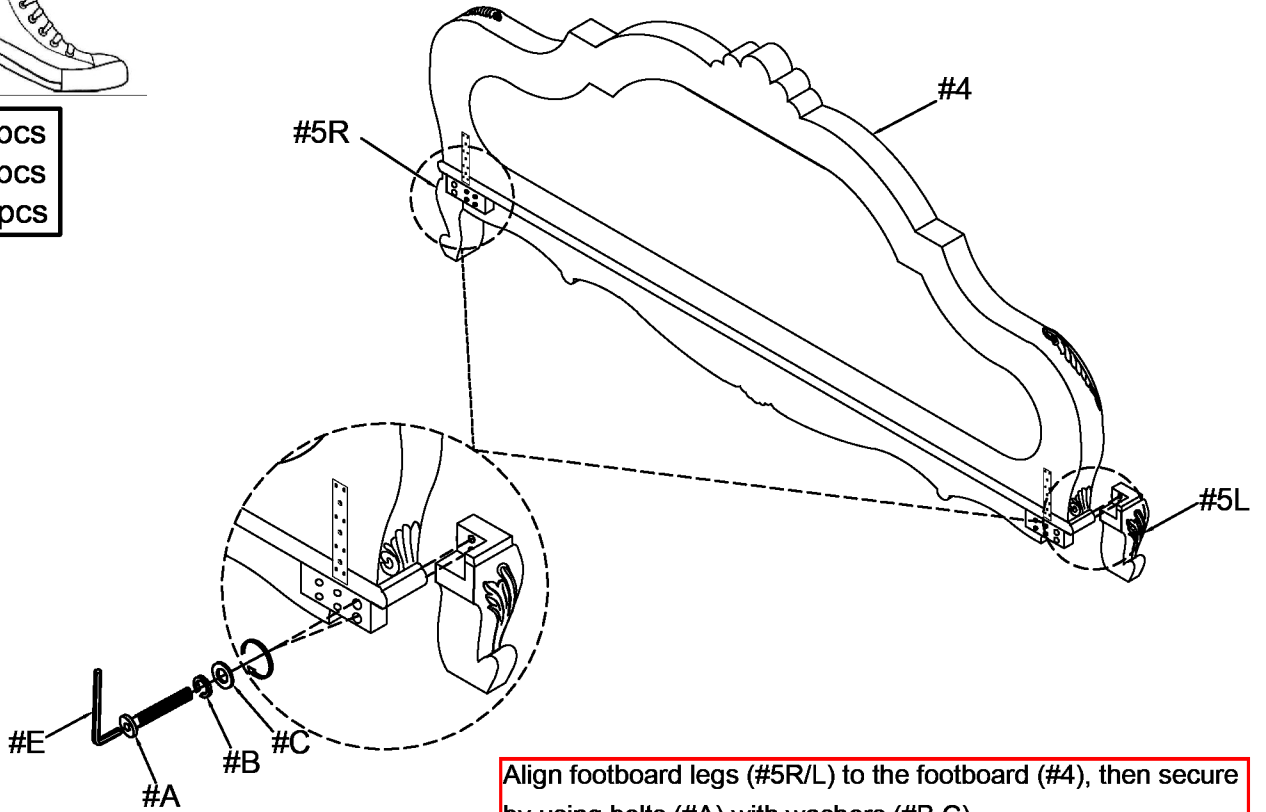

Align footboard legs (#5R/L) to the footboard (#4), then secure by using bolts (#A) with washers (#B,C).



#3

#D x 12pcs

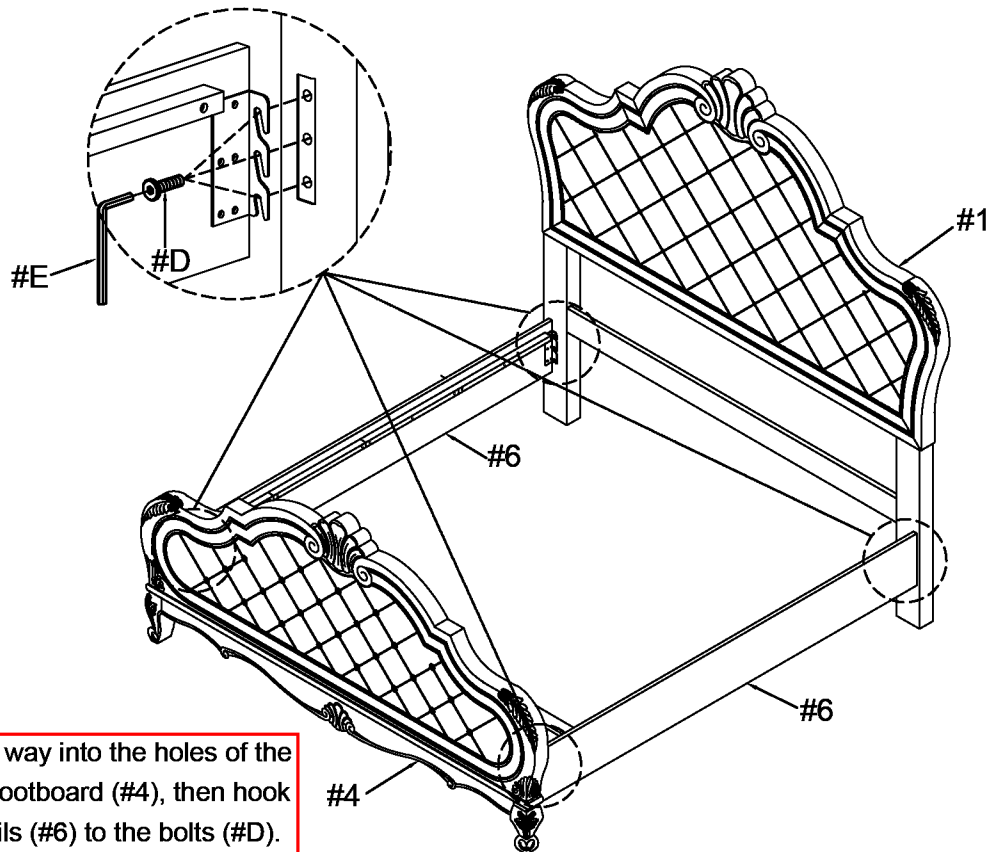

Screw bolts (#D) half way into the holes of the headboard (#1) and footboard (#4), then hook and place the side rails (#6) to the bolts (#D). Secure by tightening bolts (#D).

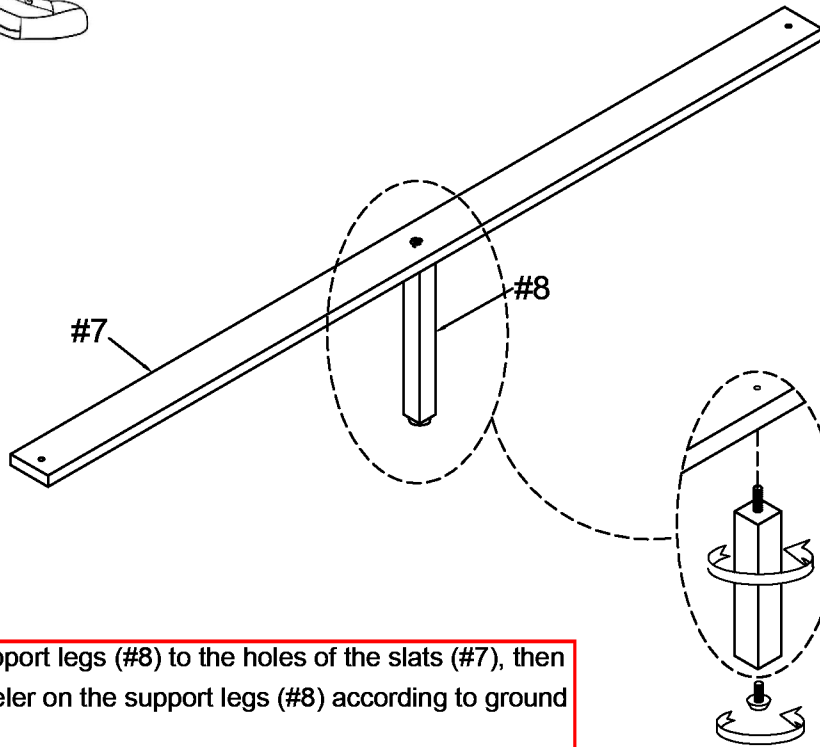

Attach support legs (#8) to the holes of the slats (#7), then adjust leveler on the support legs (#8) according to ground level.



#F x 8pcs

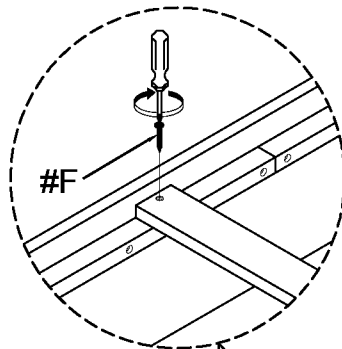

Align slats (#7) to the side rails (#6) evenly, then secure by using screws (#F).

