

INSTRUCTION MANUAL
Loft Bed

BEFORE STARTING

Before Using Product

- Read each step carefully before starting. It is very important that each step is performed in the correct order. If these steps are not followed in sequence, assembly difficulties will occur.
- Make sure all parts are included.
- Work in a spacious area and near where the unit will be used, preferably on a carpet, or use a piece of the cardboard packaging to protect your floor and product.
- For a smooth assembly process, we suggest you keep a little tightness for all the screws during assembly. After the whole product is assembled, firmly tighten all the screws.







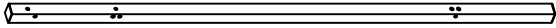
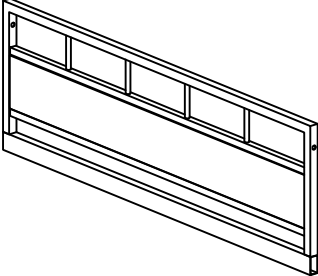
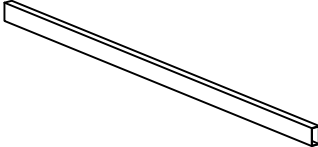
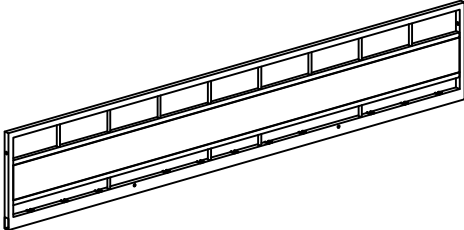
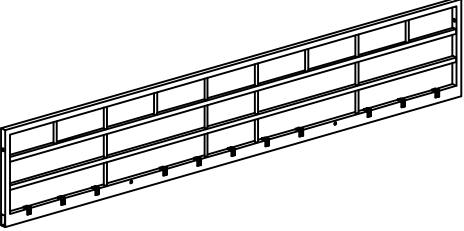
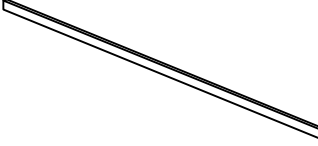
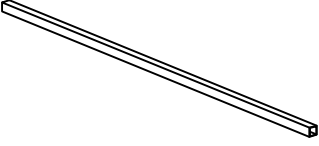
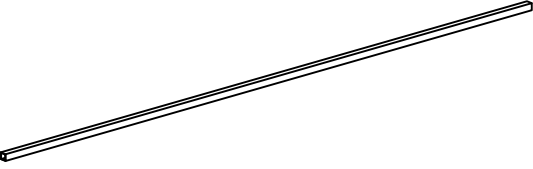
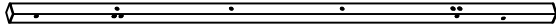
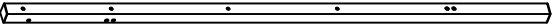

WARNING

- Do not allow children to climb on unit.
- Avoid sharp objects or corrosive chemicals to prevent damage to the product.
- During assembly, keep parts and packaging materials away from children and pets as there could be potential injury and choking hazards.
- Please make sure that all objects are removed before moving the assembled unit.
- The unit must be team lifted, not dragged or pushed. Failure to do so could cause instability, product collapse, and/or serious injury.
- Be careful when using power tools to assemble your furniture. Power tools may strip or damage the parts.

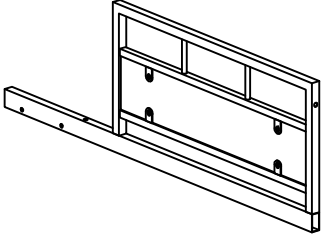

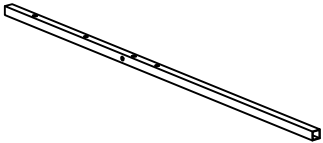
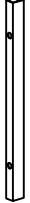
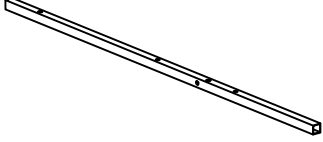
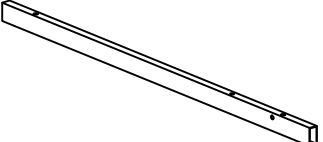
PART LIST

<p>① ×2</p> 	<p>② ×1</p> 
<p>③ ×1</p> 	<p>④ ×1</p> 
<p>⑤ ×1</p> 	<p>⑥ ×11</p> 
<p>⑦ ×2</p> 	<p>⑧ ×1</p> 
<p>⑨ ×1</p> 	<p>⑩ ×1</p> 

PART LIST

<p>11</p>  <p>x2</p>	<p>12</p>  <p>x1</p>
<p>13</p>  <p>x1</p>	<p>14</p>  <p>x1</p>
<p>15</p>  <p>x2</p>	<p>16</p>  <p>x1</p>
<p>17</p>  <p>x1</p>	<p>18</p>  <p>x1</p>
<p>19</p>  <p>x2</p>	<p>20</p>  <p>x3</p>

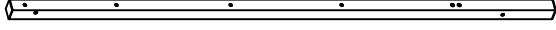
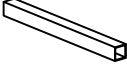
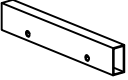
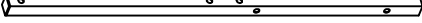
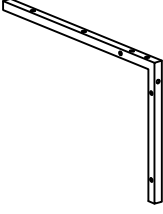
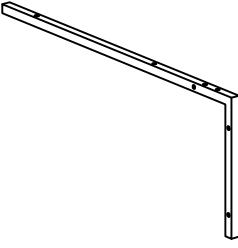
PART LIST

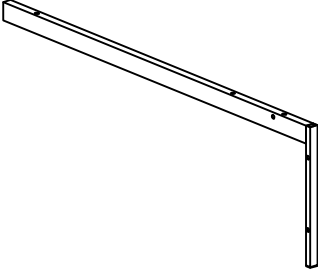
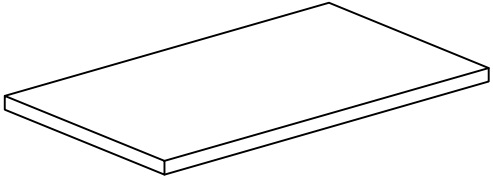
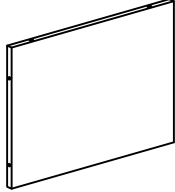
<p>21 ×1</p> 	<p>22 ×1</p> 
<p>23 ×1</p> 	<p>24 ×1</p> 
<p>25 ×1</p> 	<p>26 ×1</p> 
<p>27 ×2</p> 	<p>28 ×1</p> 
<p>29 ×1</p> 	<p>30 ×1</p> 

PART LIST

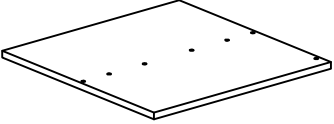
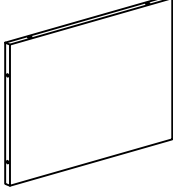
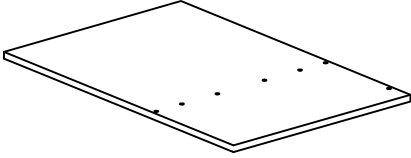
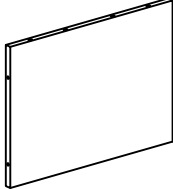
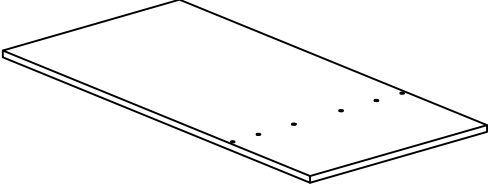
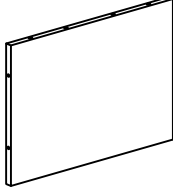
<p>31 ×1</p> 	<p>32 ×1</p> 
<p>33 ×1</p> 	<p>34 ×1</p> 
<p>35 ×1</p> 	<p>36 ×1</p> 

PART LIST

A



x10

B



x18

C



x10

D



x23

E



x3

F



x18

G



x4

H



x4

I



x2

J



x1

K



x6

L



x22

M



x41

N

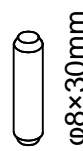

x14

O

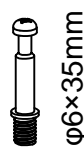

x4

P



x4

Q



x2

R

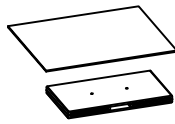

x2

S



x4

T



x2

U



x8

V

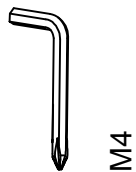

x2

ASSEMBLY INSTRUCTION

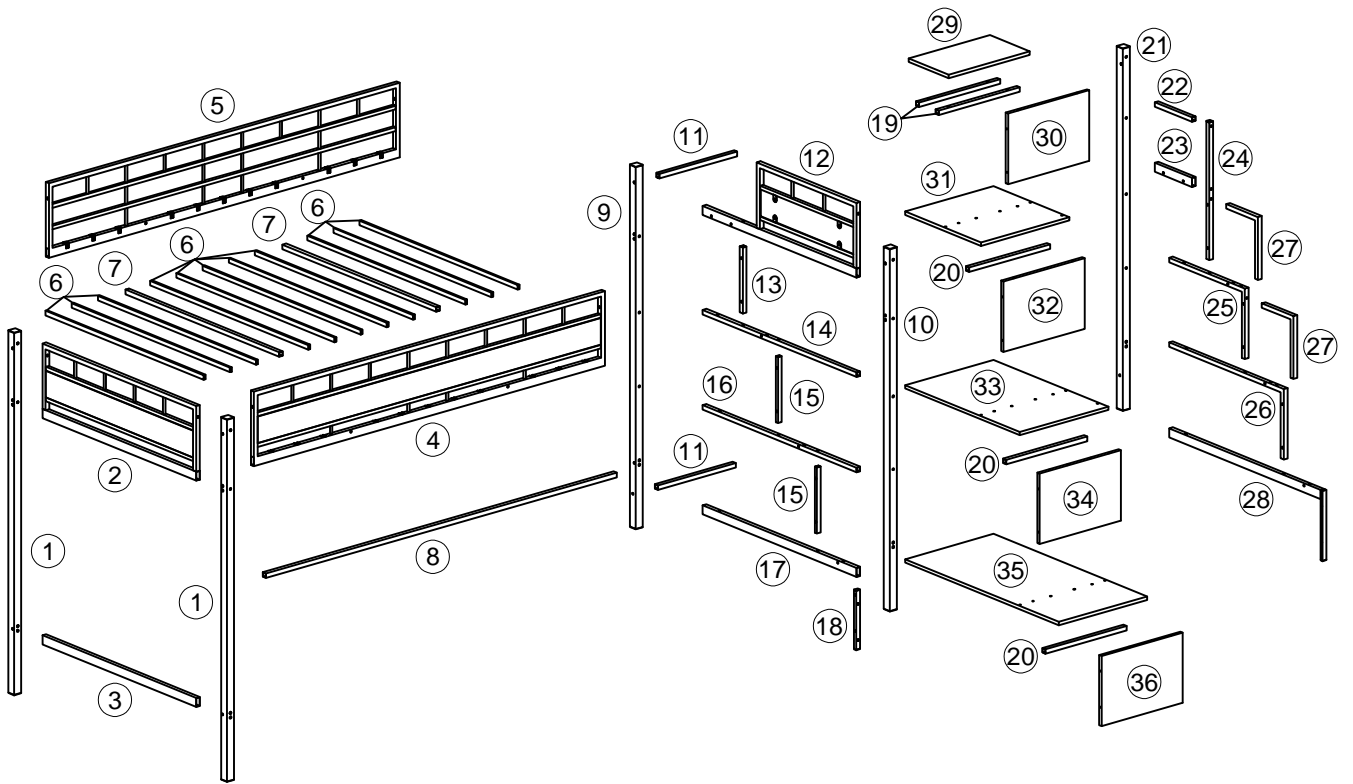

ASSEMBLY INSTRUCTION

1

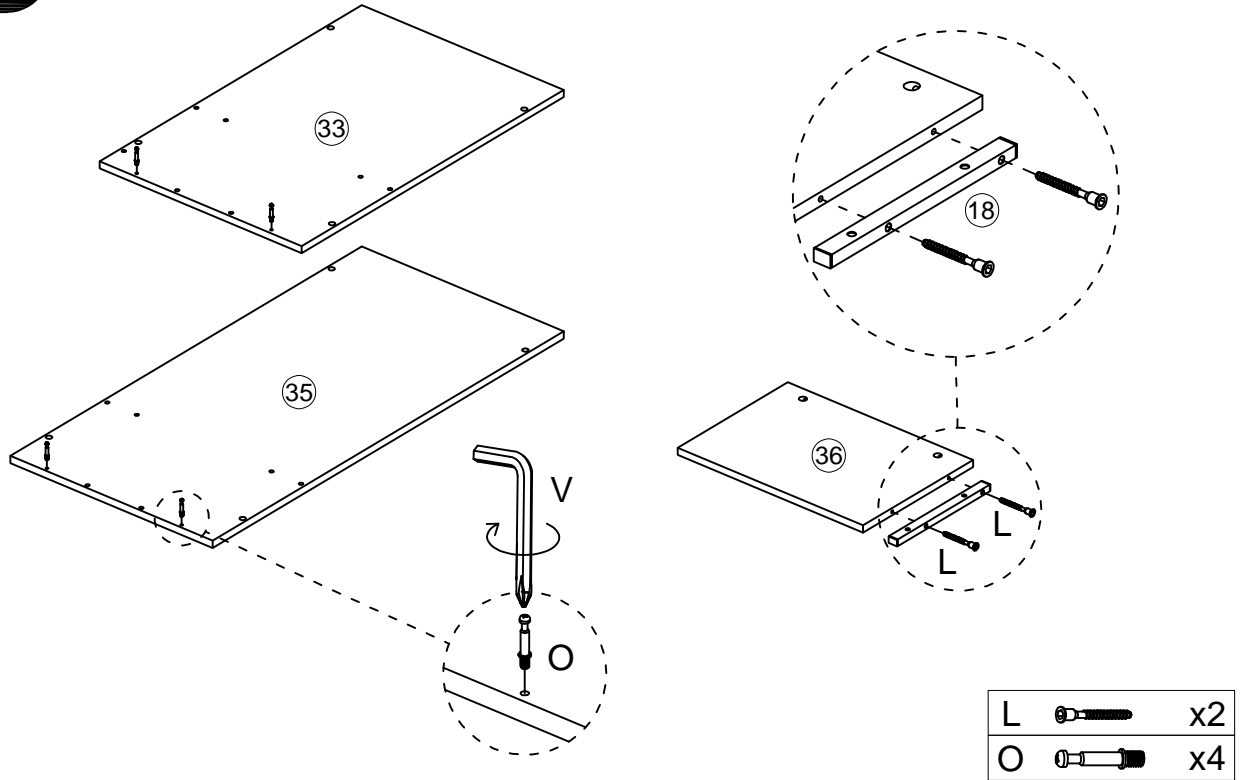

2

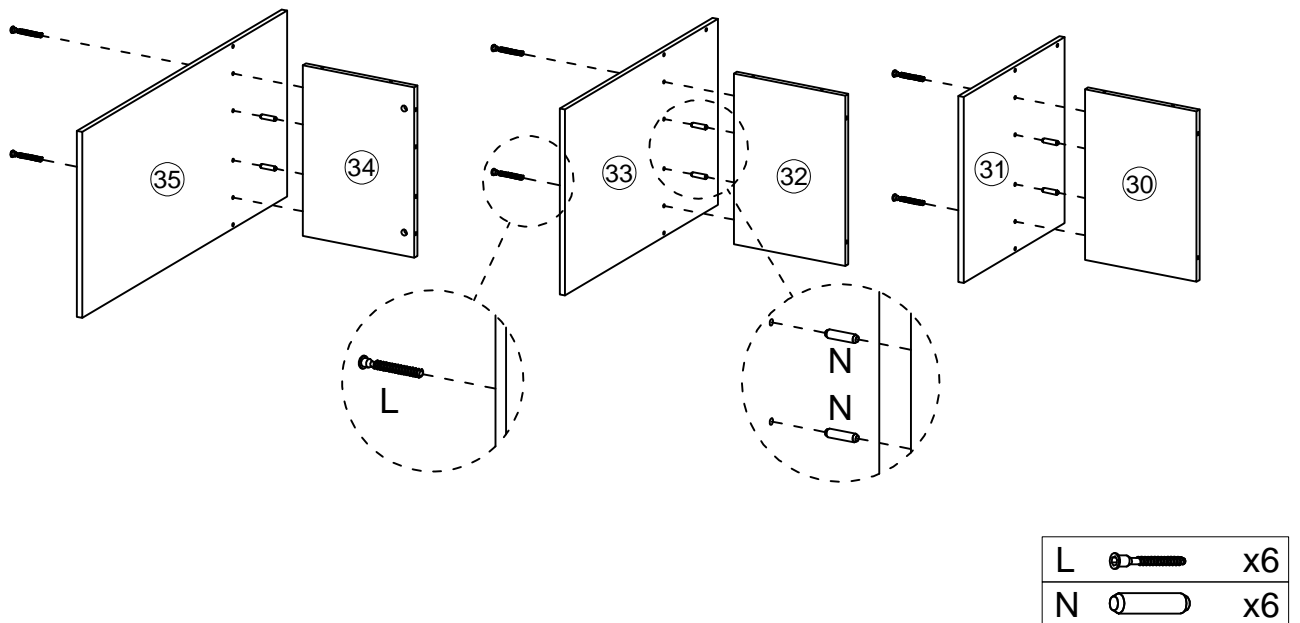

ASSEMBLY INSTRUCTION

3

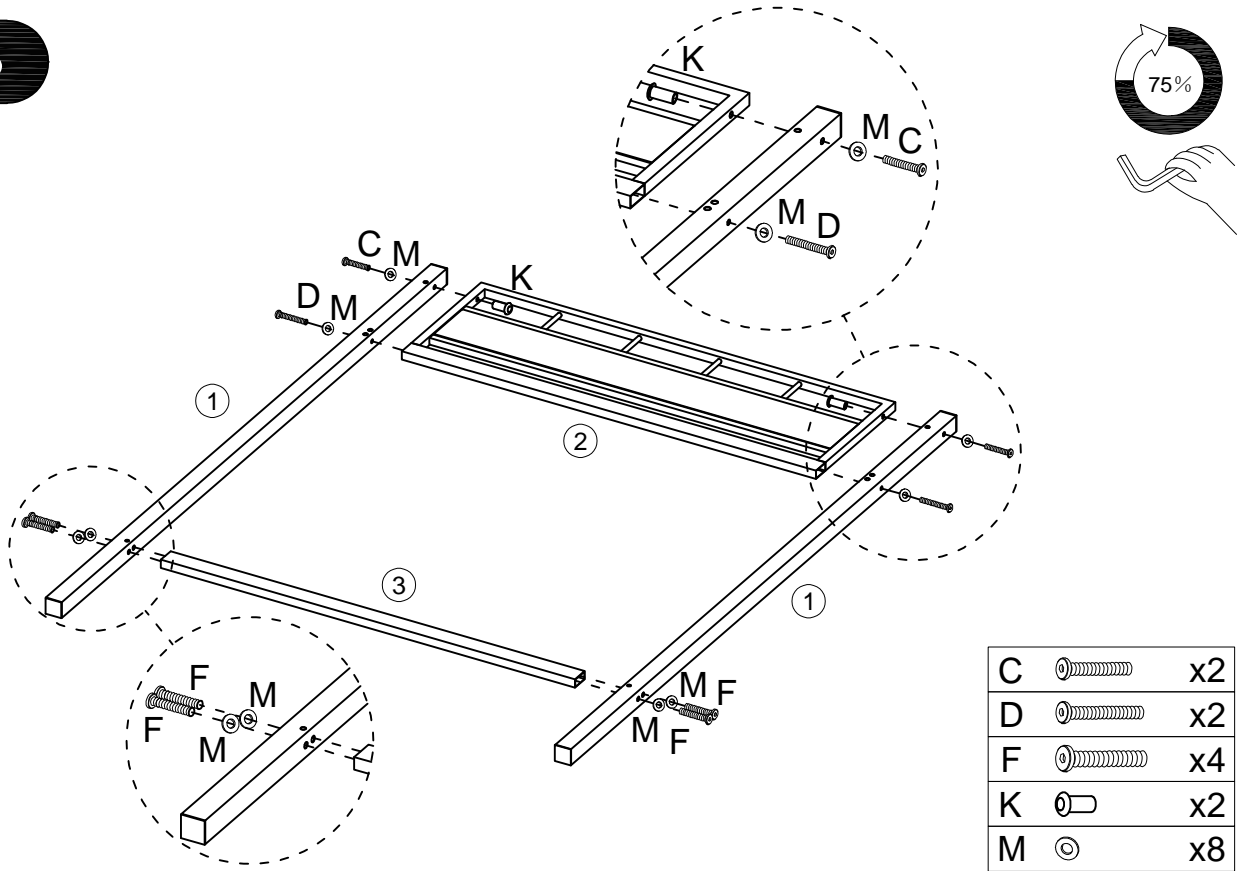

4

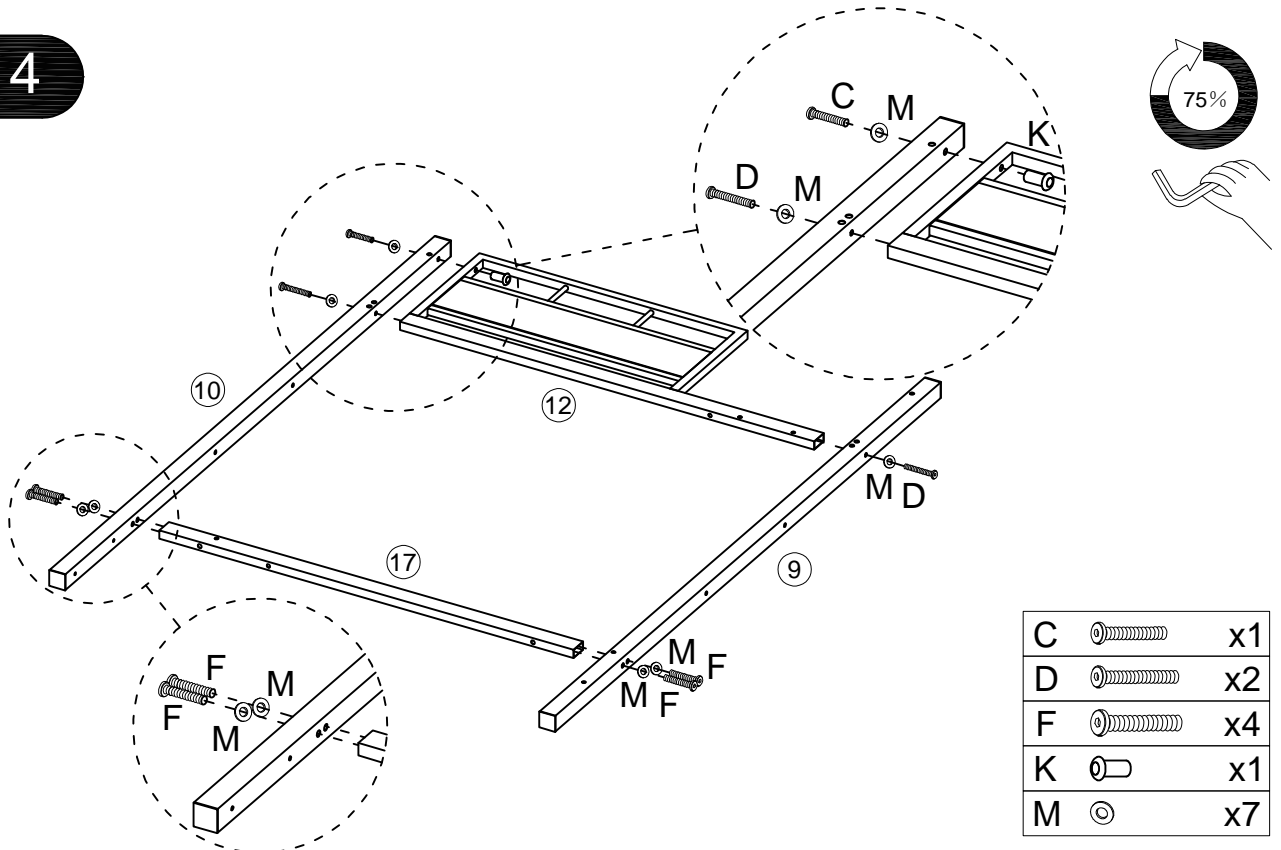

ASSEMBLY INSTRUCTION

5

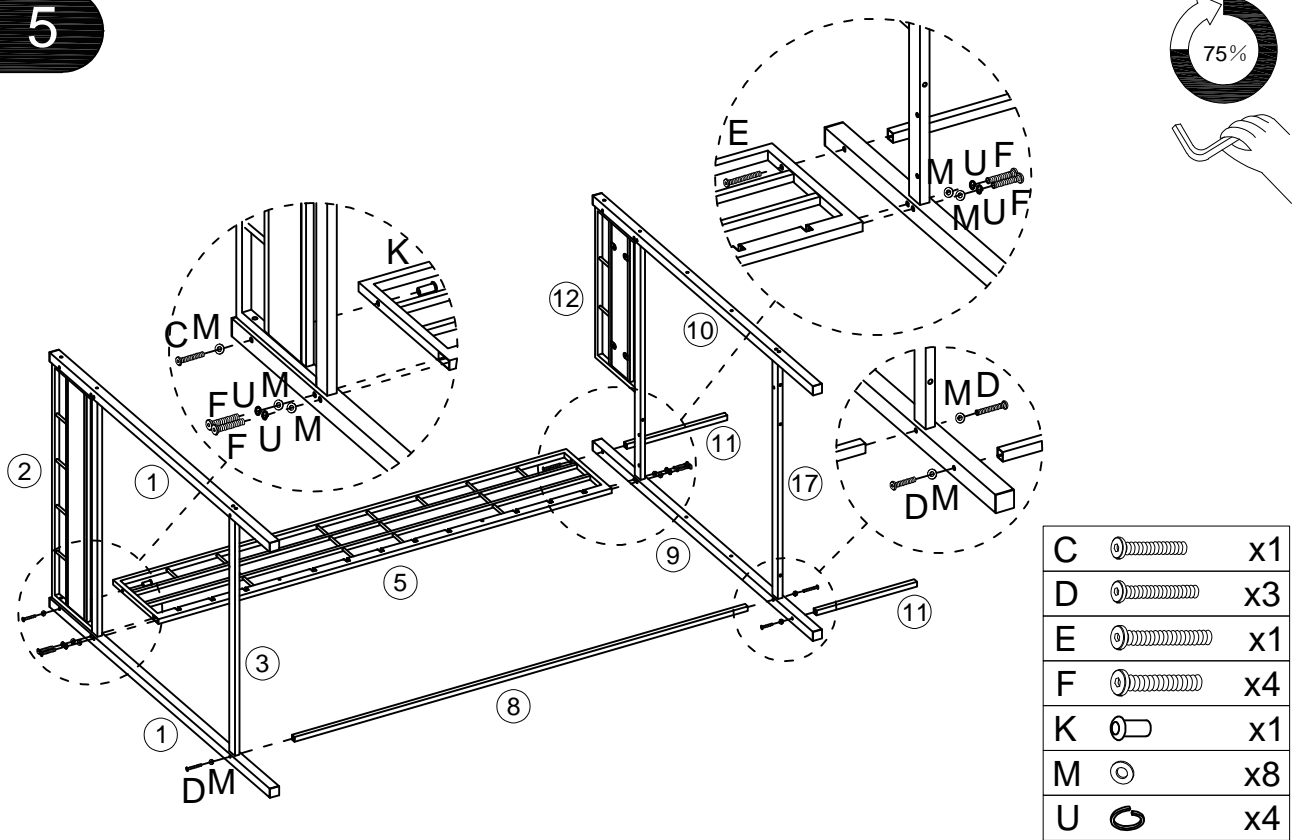

C		x1
D		x3
E		x1
F		x4
K		x1
M		x8
U		x4

6

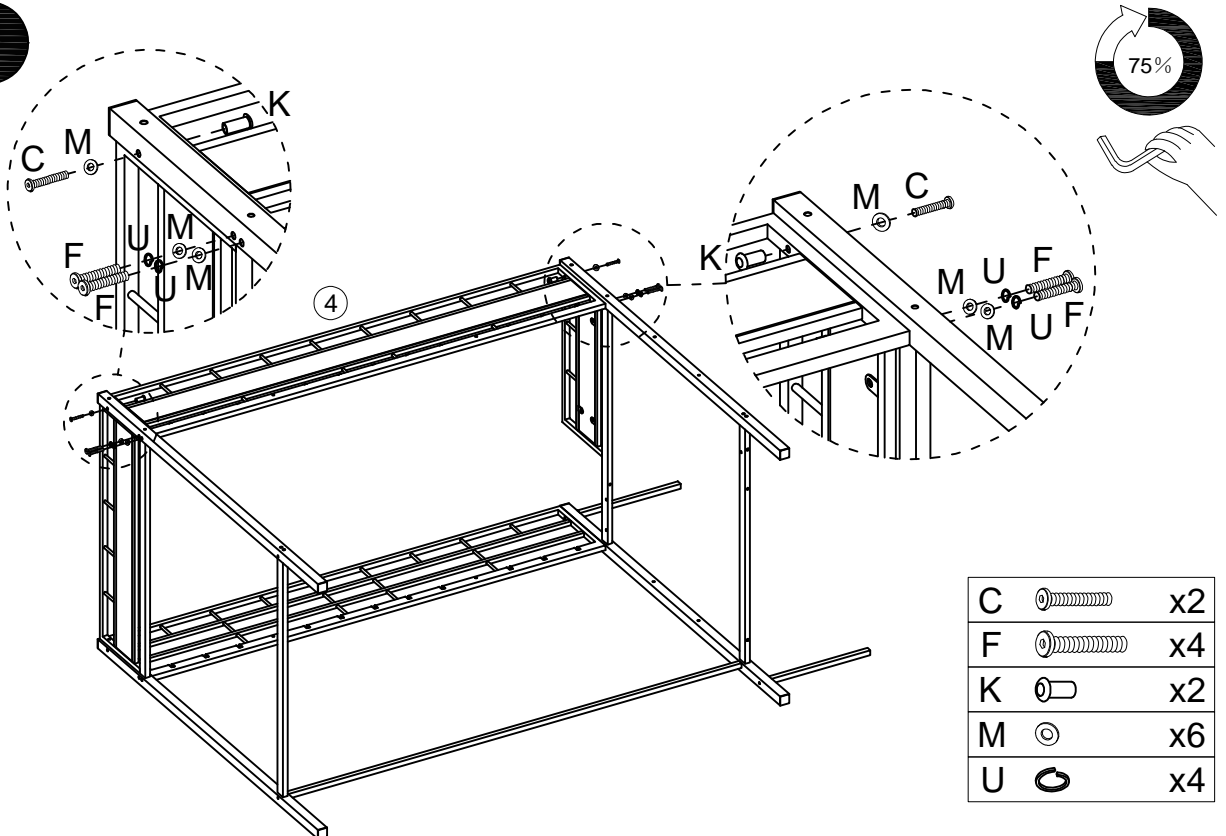

C		x2
F		x4
K		x2
M		x6
U		x4

ASSEMBLY INSTRUCTION

7

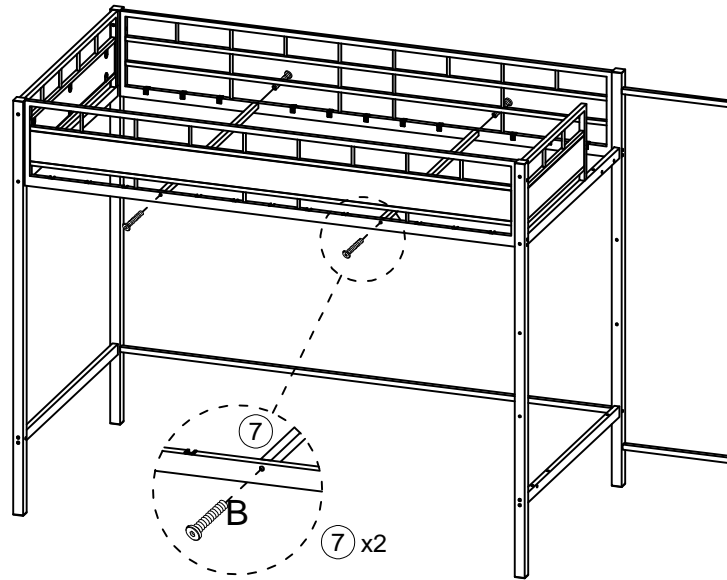
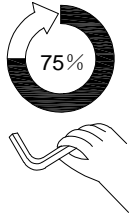

B  x4

8

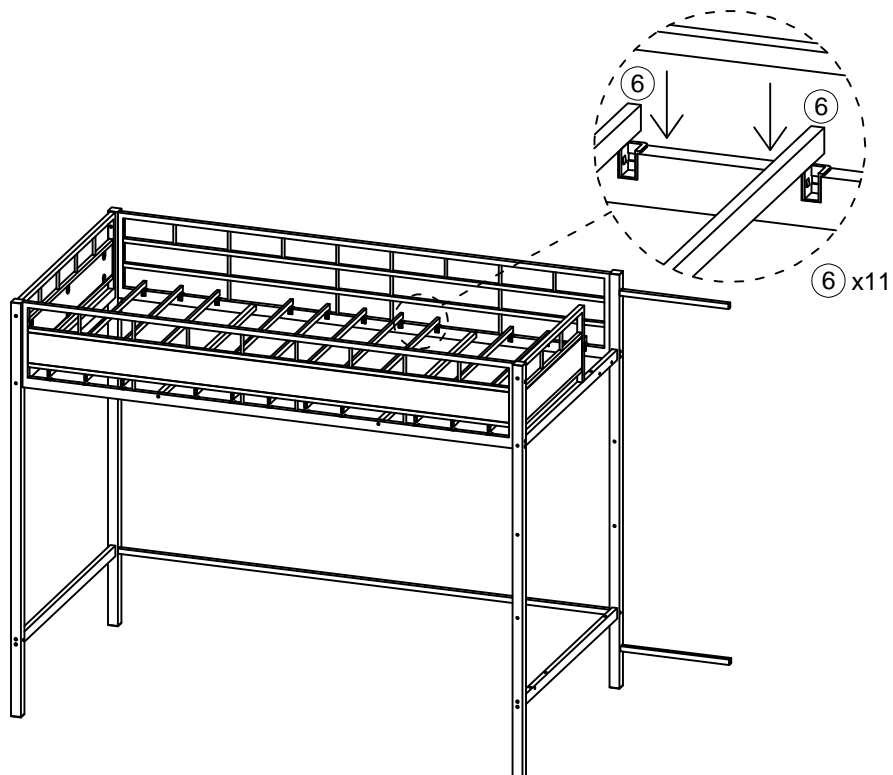

ASSEMBLY INSTRUCTION

9

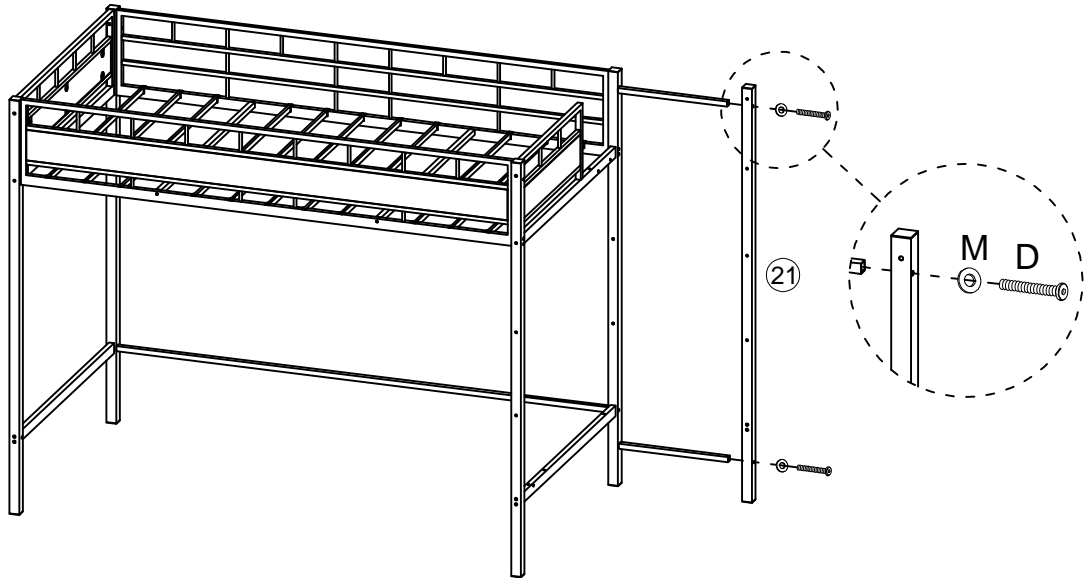
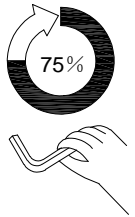

D		x2
M		x2

10

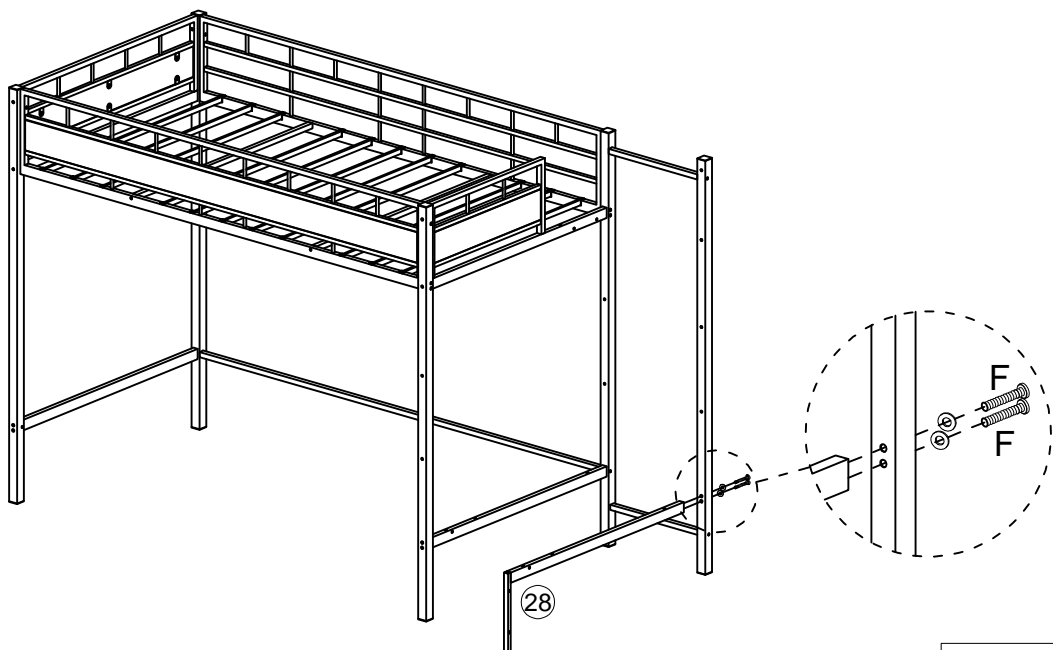
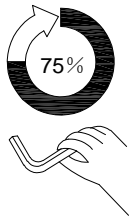

F		x2
M		x2

12

ASSEMBLY INSTRUCTION

11

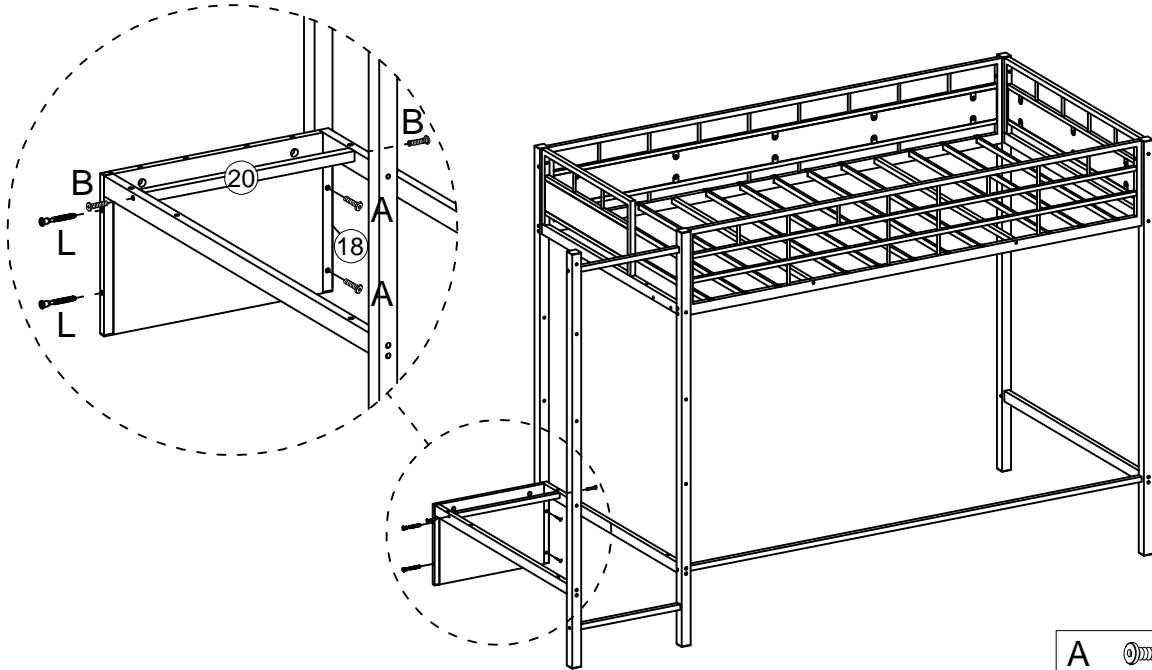
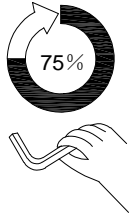

A		x2
B		x2
L		x2

12

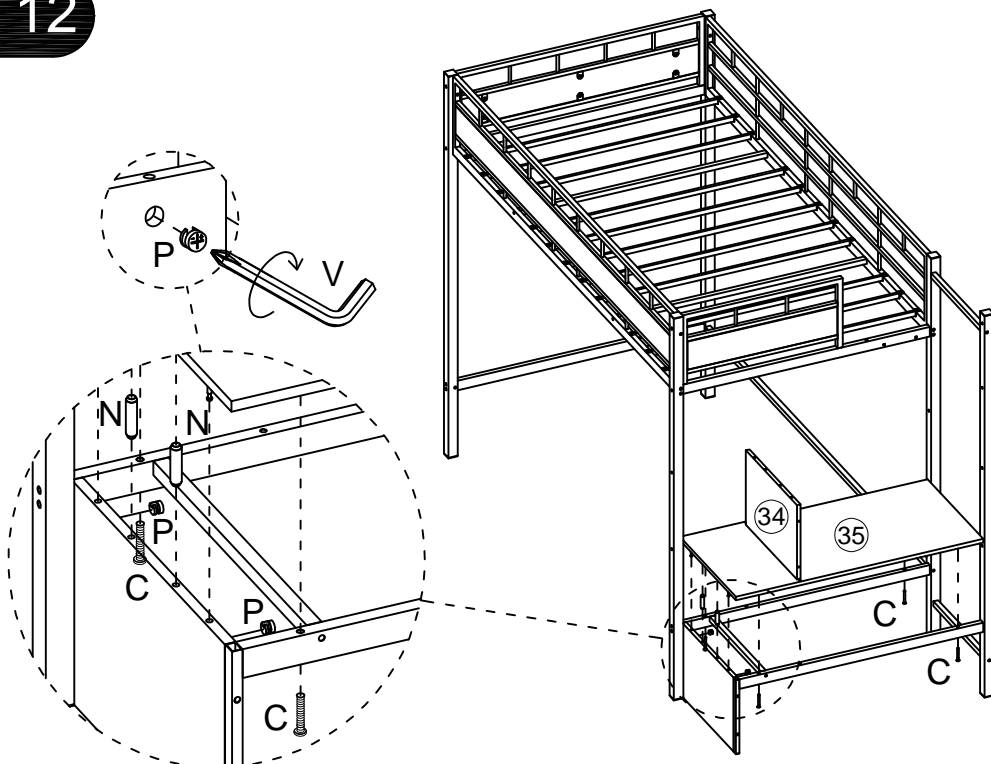
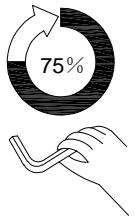

C		x4
N		x2
P		x2

ASSEMBLY INSTRUCTION

13

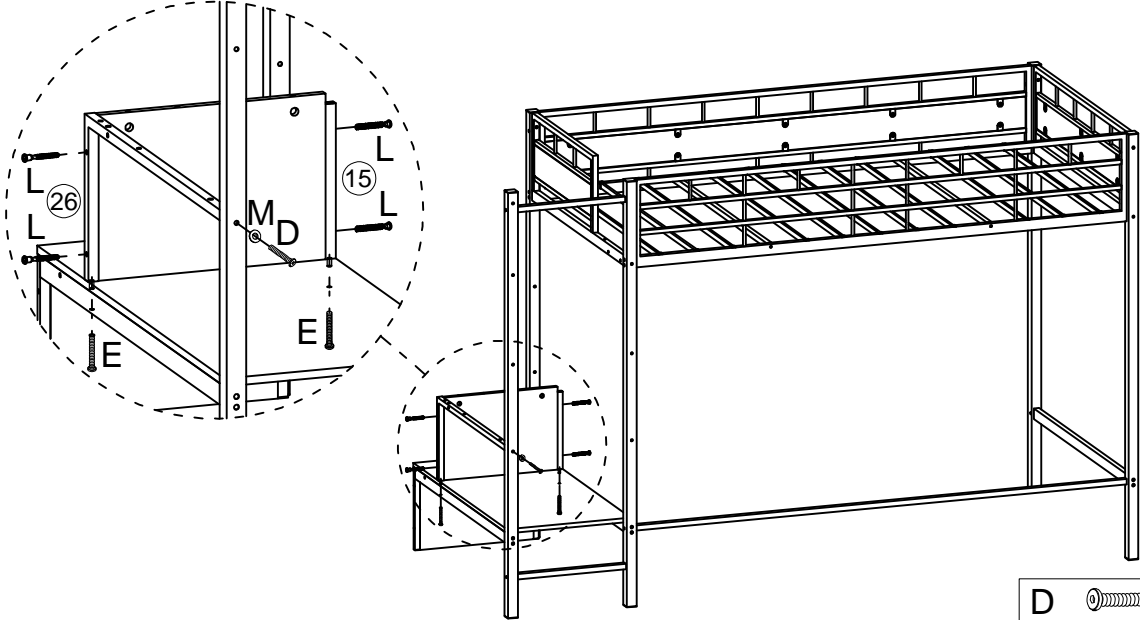
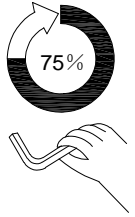

D		x1
E		x2
L		x4
M		x1

14

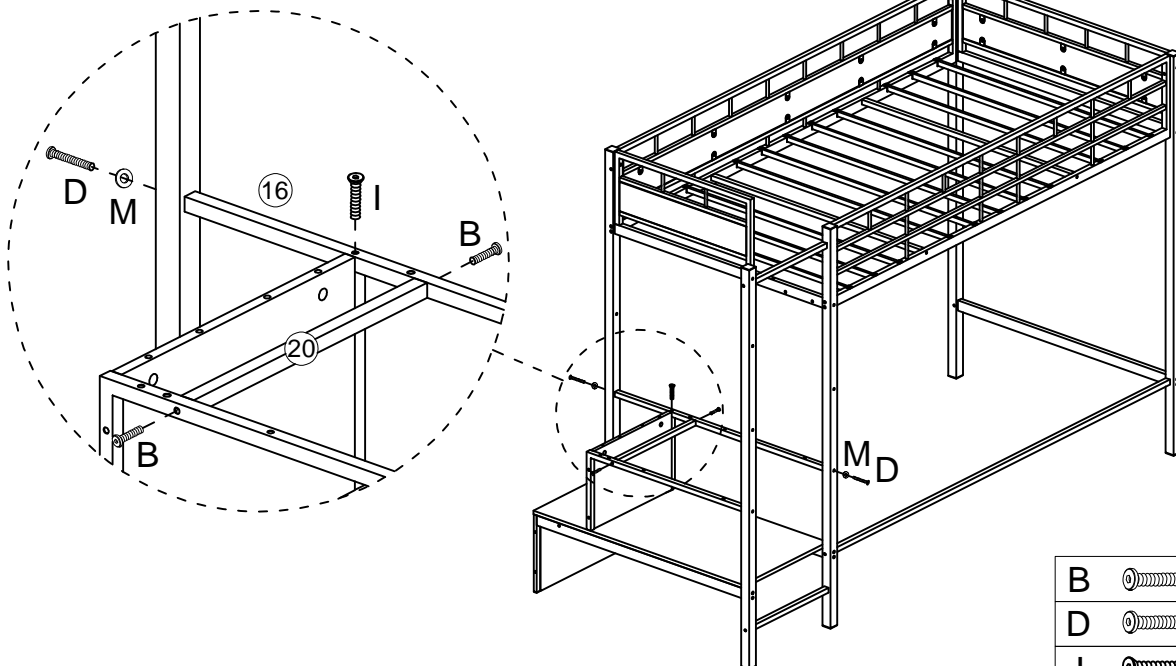
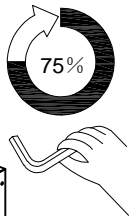

B		x2
D		x2
I		x1
M		x2

ASSEMBLY INSTRUCTION

15

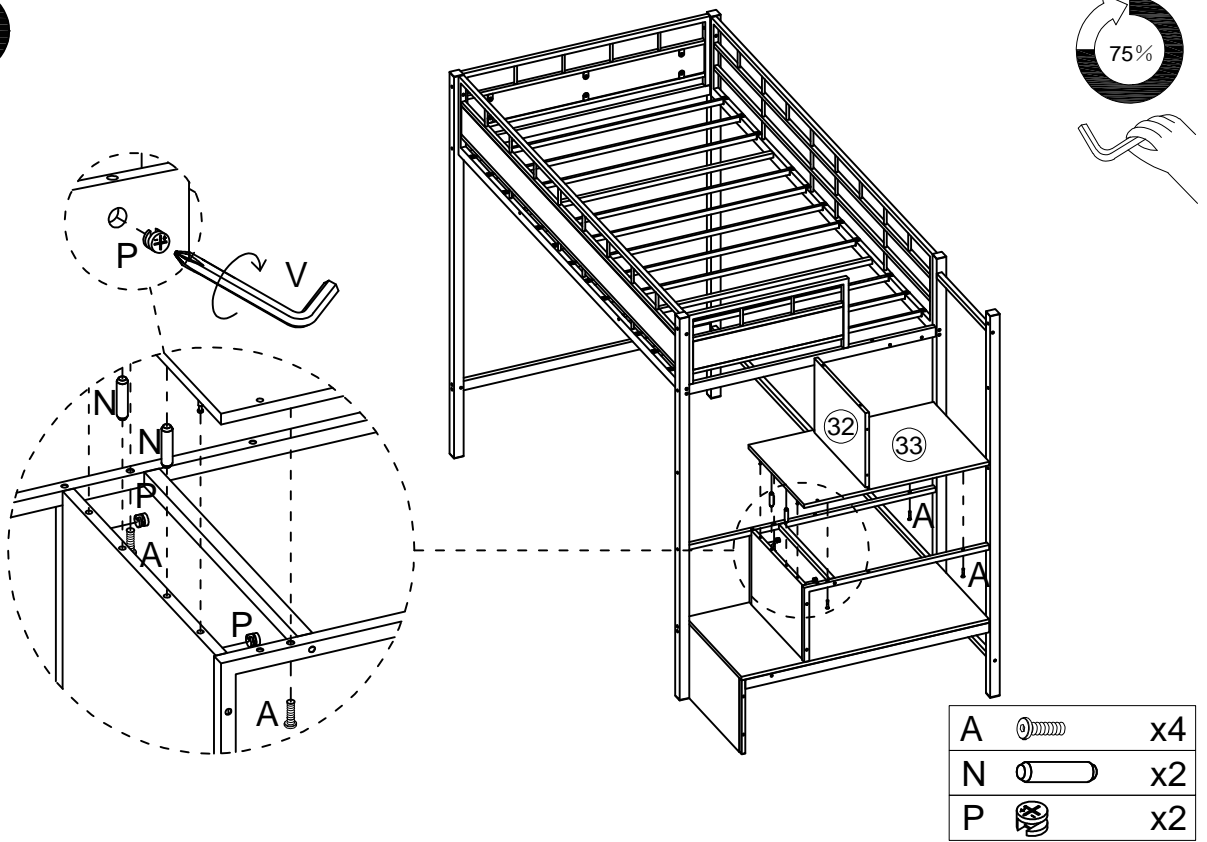

16

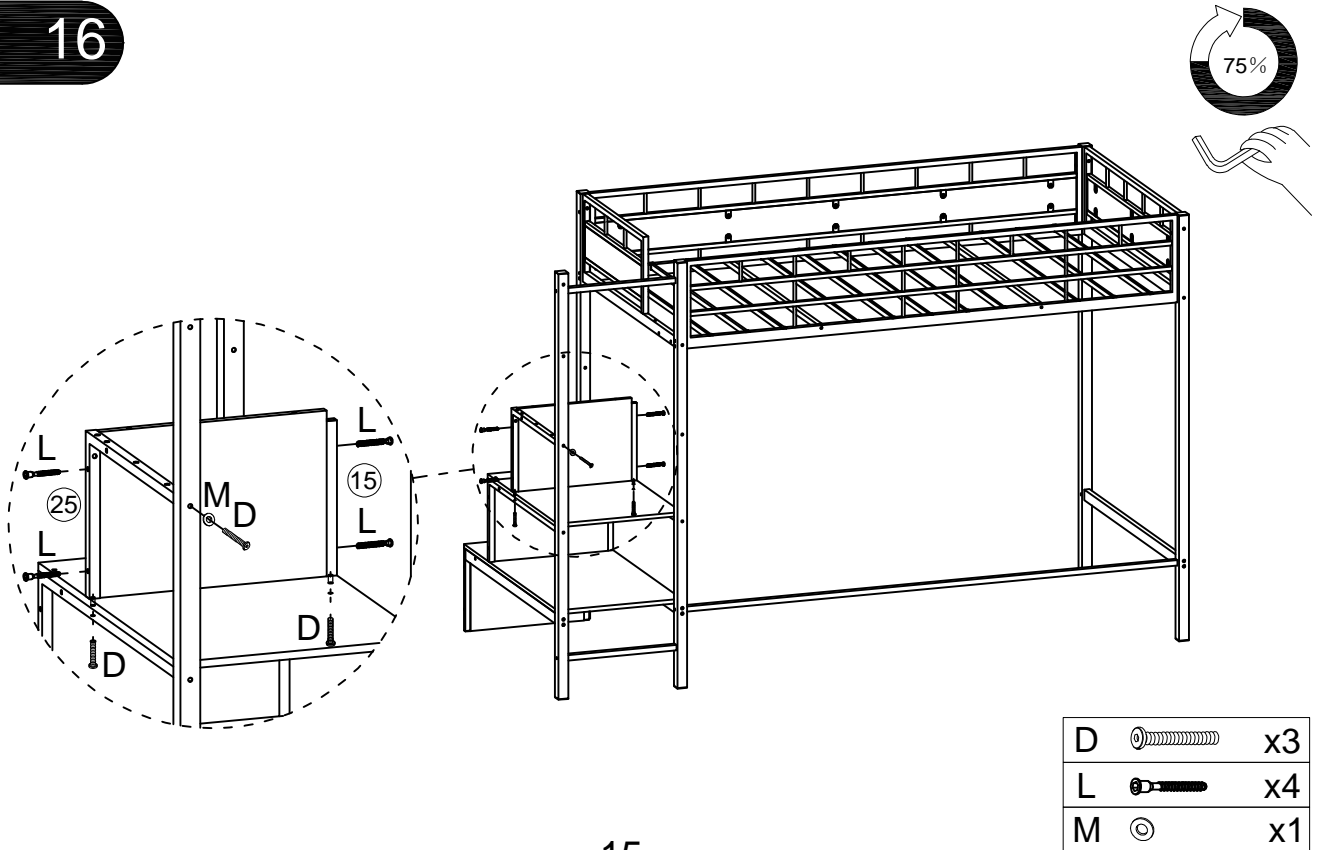

17

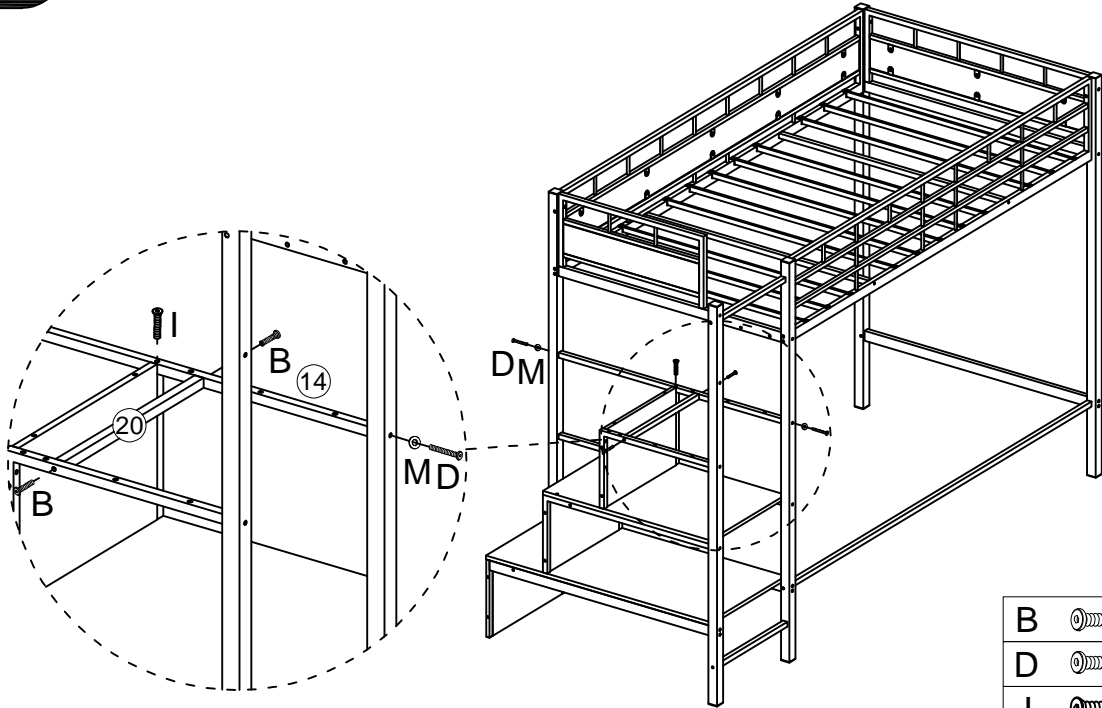
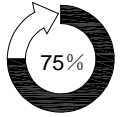

B		x2
D		x2
I		x1
M		x2

18

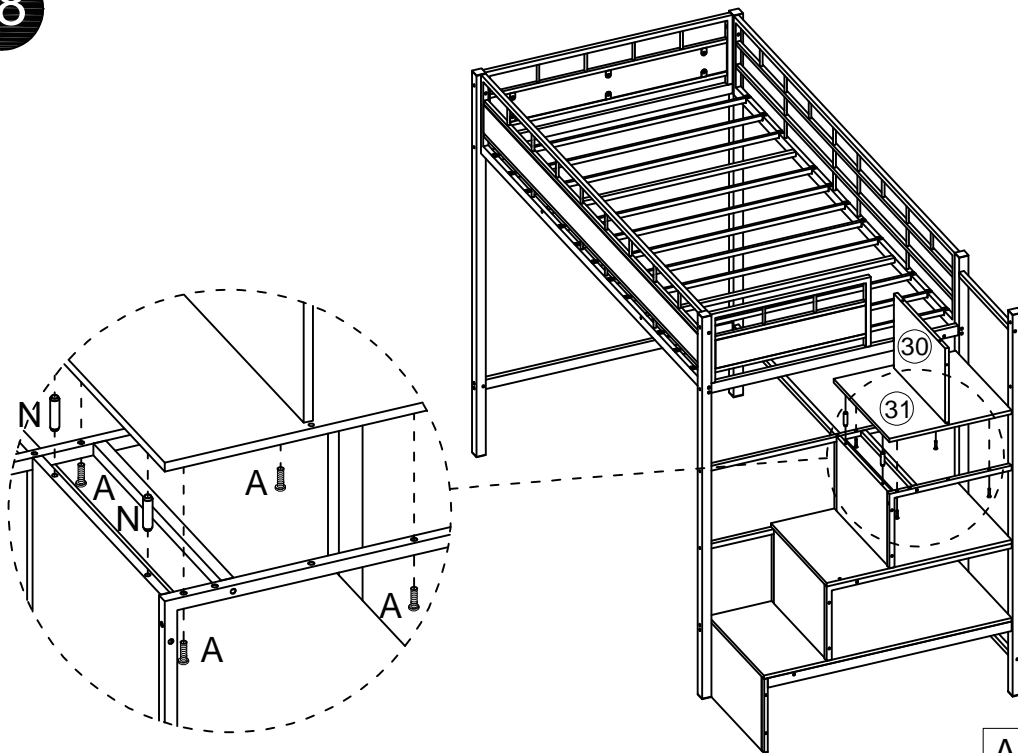

A		x4
N		x2

ASSEMBLY INSTRUCTION

19

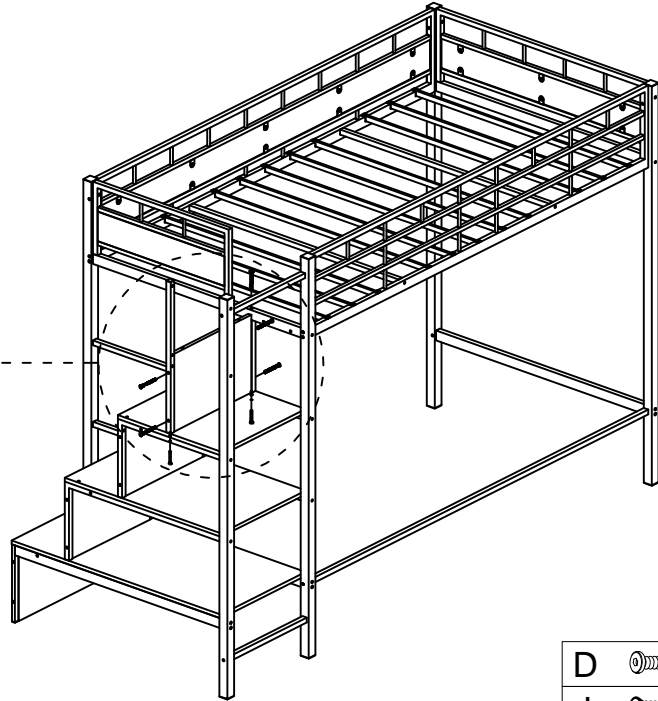
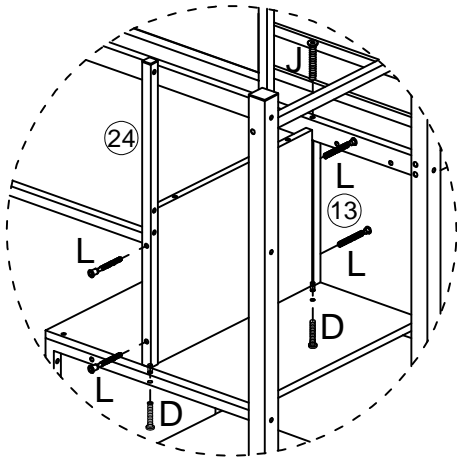
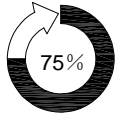

D		x2
J		x1
L		x4

20

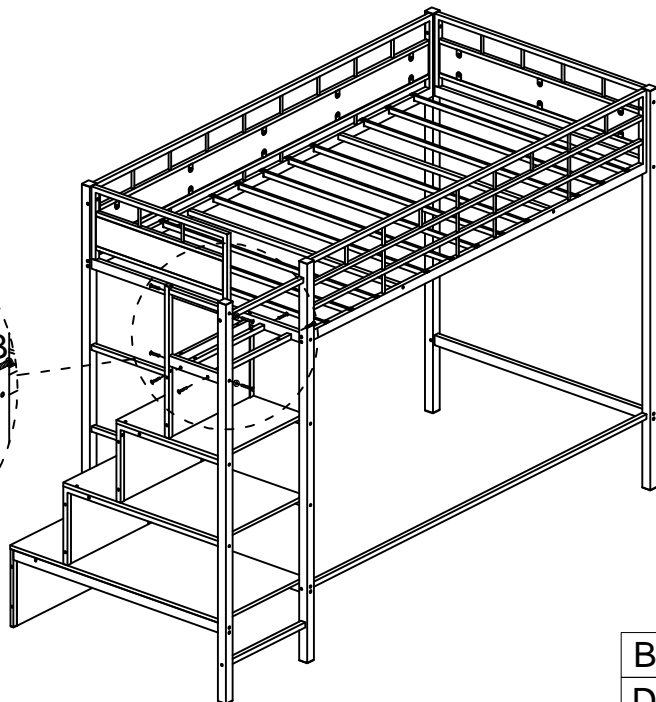
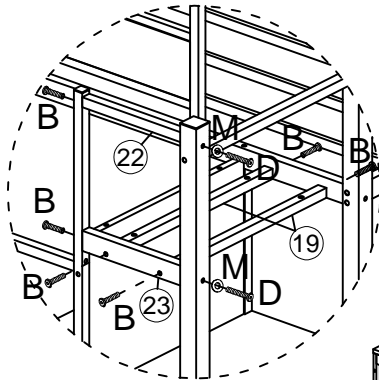

B		x6
D		x2
M		x2

ASSEMBLY INSTRUCTION

21

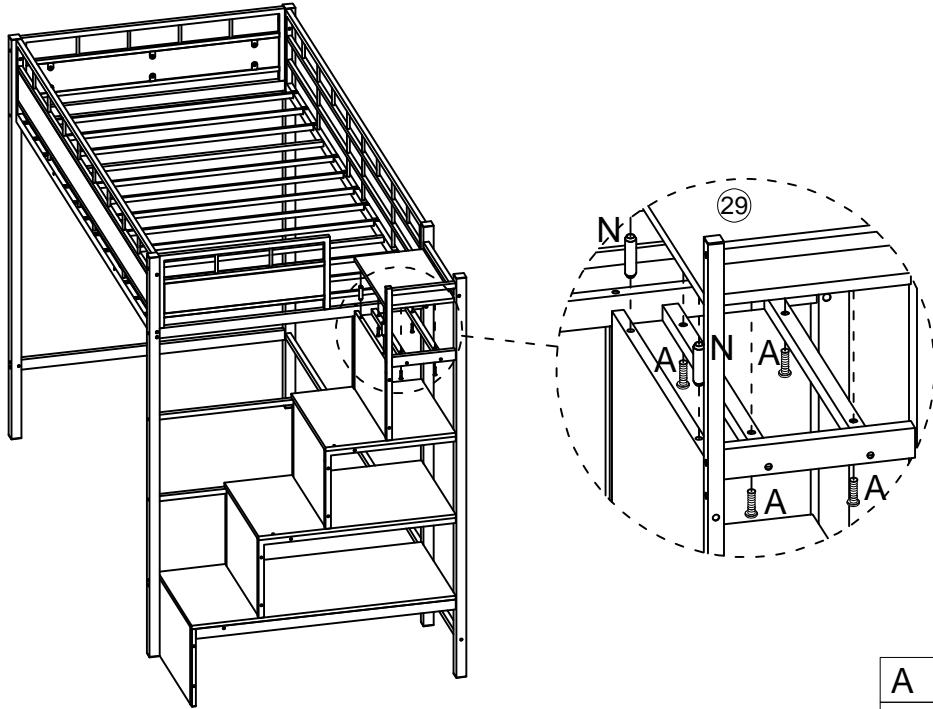
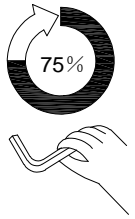

A		x4
N		x2

22

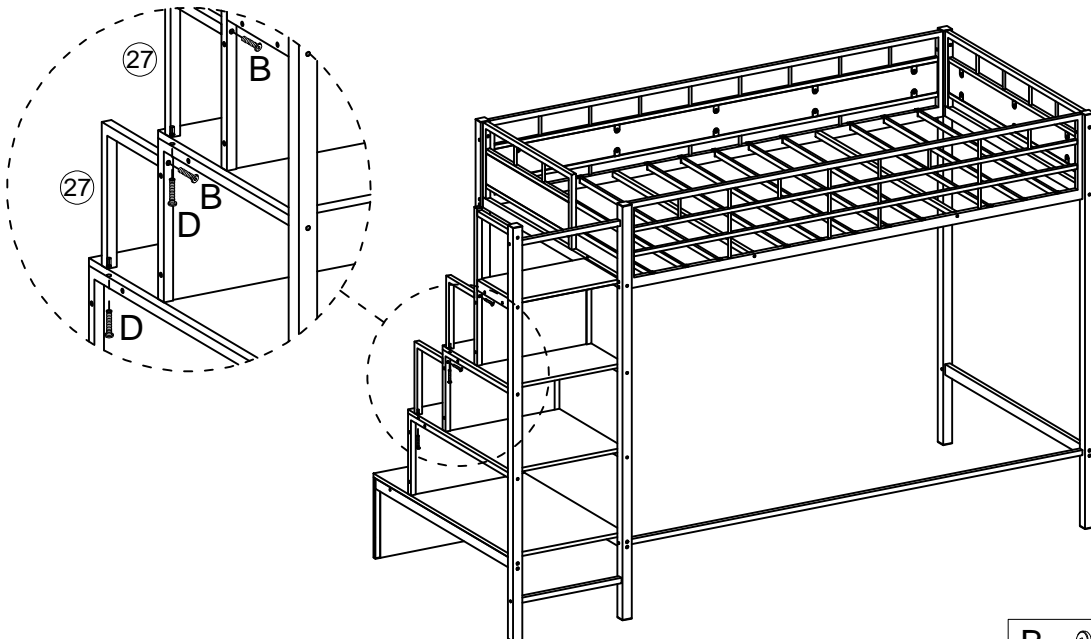
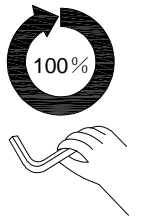

B		x2
D		x2

23

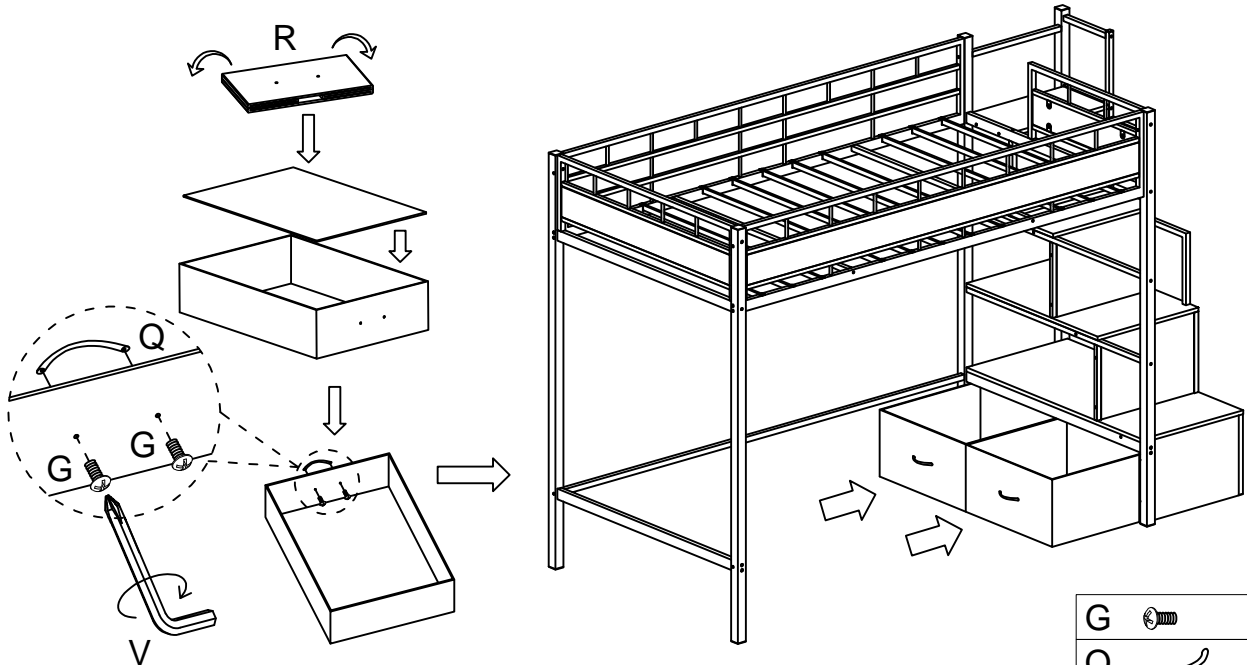

G		x4
Q		x2
R		x2

24

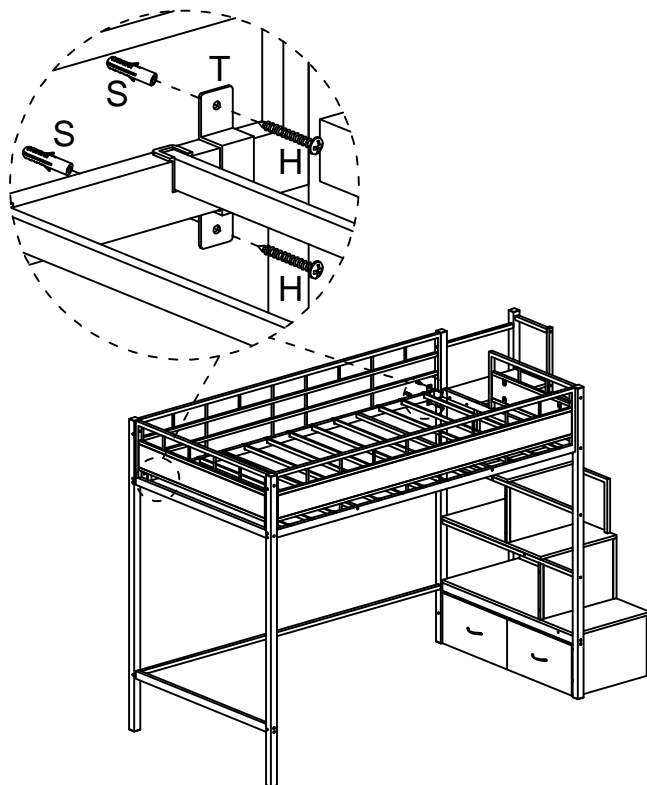

H		x4
S		x4
T		x2