

Assembly Instructions

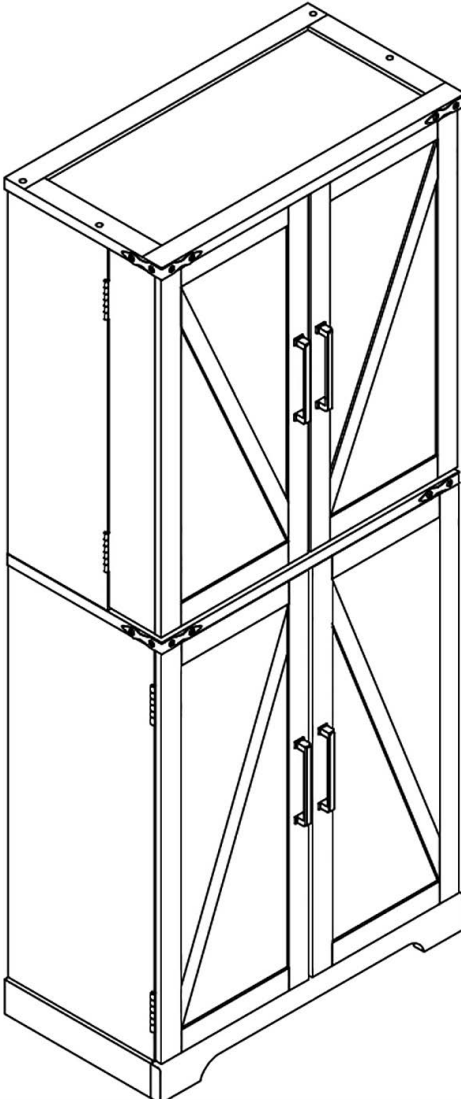

General Assembly Guidelines

- I. Ensure that all parts and hardware are available before beginning assembly.
- II. Follow each step carefully to ensure the proper assembly of this product.
- III. Two people are recommended for ease in the assembly of this product.
- IV. The three main types of hardware used to assemble this product are : wood dowels , screws and bolts.
- V. The provided glue is to secure wood dowels in place . When first inserting dowels , locate the appropriate hole for the dowel , place a small amount of glue in the hole and insert the dowel . Wipe away excess glue immediately.

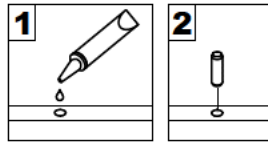

In future assembly steps when dowels are necessary to attach assembly parts together , place a small amount of glue on the end of the dowel before attaching parts together . Wipe away excess glue immediately.

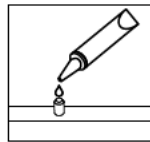

- VI. A Phillips head screwdriver is required for the assembly of this product .

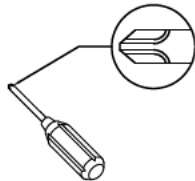

- VII. Power tools should not be used to assemble this product .

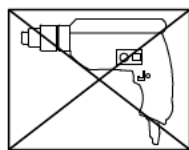

- VIII. Concealed hinges are three-way adjustable.

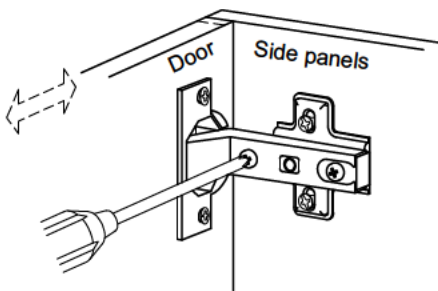

Horizontal
by screw adjustment

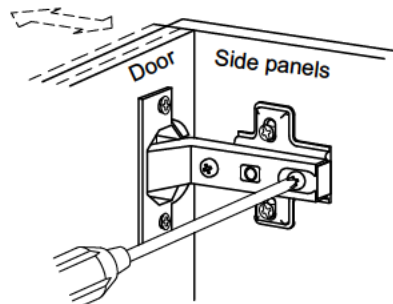

In-and-Out
by loosening the hinge-arm
mounting screw or via cam
adjustment

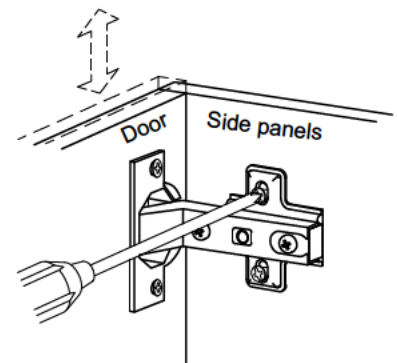





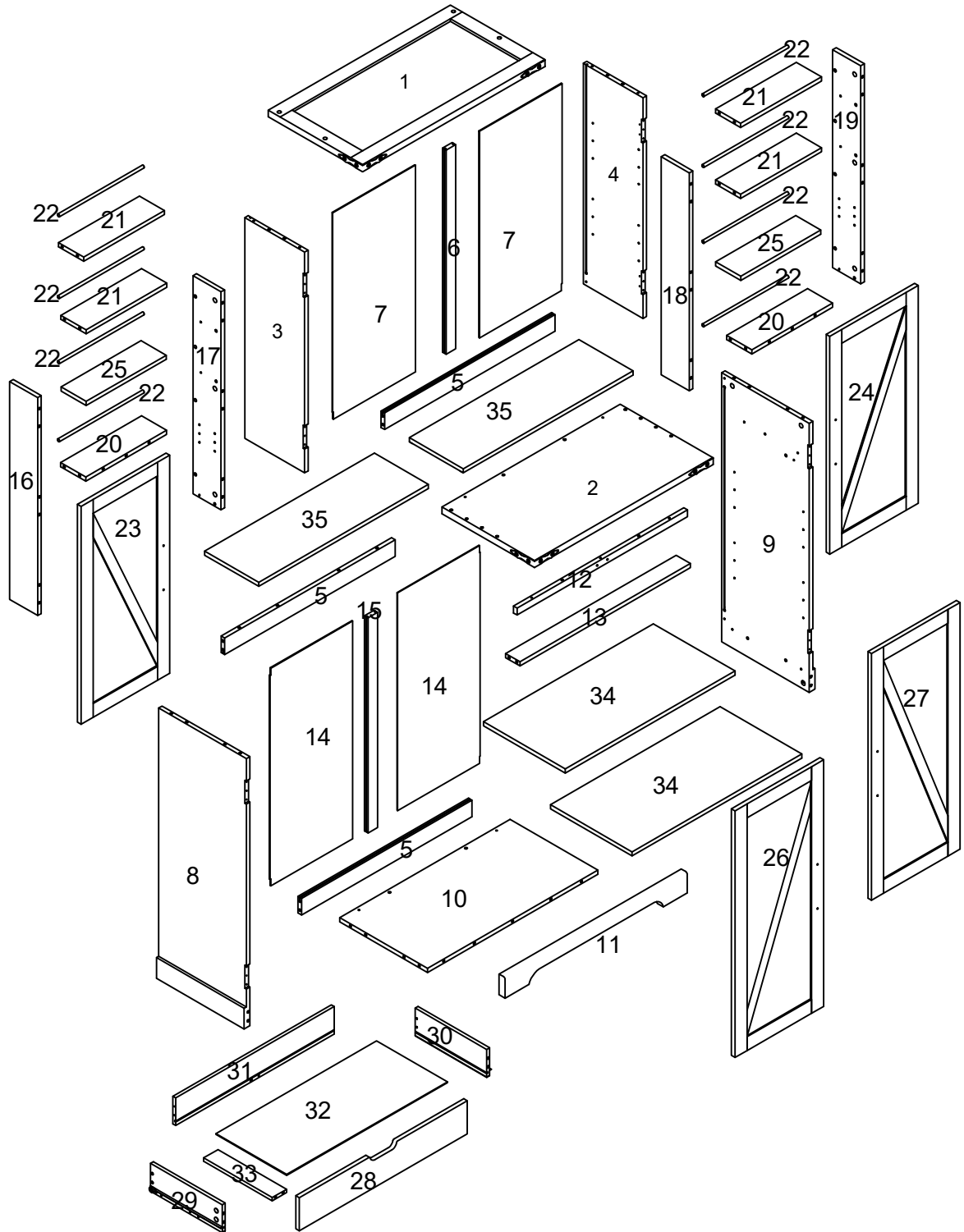











Vertical
Via slots in the mounting
plate or via cam adjustment

Parts List



Hardware List

A		Ø8x30mm	Wooden dowel	64 pcs
B		Ø6x35mm	Cam lock	60 pcs
C		Ø15x11mm	Cam lock	55 pcs
D		Ø15x9mm	Cam lock	5 pcs
E		Ø30mm	Sticker	60 pcs
F		Ø6x50mm	Bolt	8 pcs
G		M 4	Hex Key	1 pc
H			Hold hands	4 pcs
I		Ø4x19mm	Screw	8 pcs
J			Bolt	2 pcs
K			Magnetic bump	2 pcs
L			Bolt	2 pcs
M		Ø3x15mm	Screw	4 pcs
N		Ø5x13x26mm	Shelf support pin	24 pcs
O		Ø3.5x15mm	Screw	56 pcs
P			Three fold hinge	4 pcs

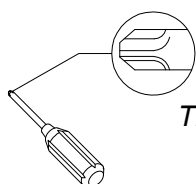

Philips head screwdriver required for assembly
(not included)

*The hardware quantities listed above are required for proper assembly.
Some extra hardware may also have been included.*

Hardware List

Q		Individually packed	Drawer slides	1 pcs
R		Ø3x12mm	Screw	20 pcs
S			Two fold hinge	4 pcs
T			Plastic wedge	16 pcs
U		Ø3x17mm	Screw	16 pcs
V		Ø4x32mm	Screw	8 pcs
W			Anti falling hardware	4 pcs
X		Ø4x15mm	Screw	4 pcs
Y		Ø4x35mm	Screw	4 pcs
Z			House lizard	4 pcs
AA			Strip	2 pcs
BB			Small White Glue	1 pc

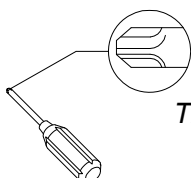

Philips head screwdriver required for assembly
(not included)

*The hardware quantities listed above are required for proper assembly.
Some extra hardware may also have been included.*

Step 1

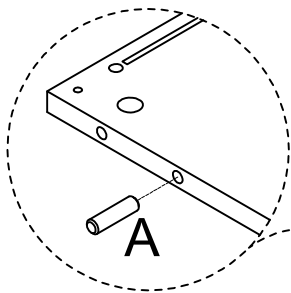
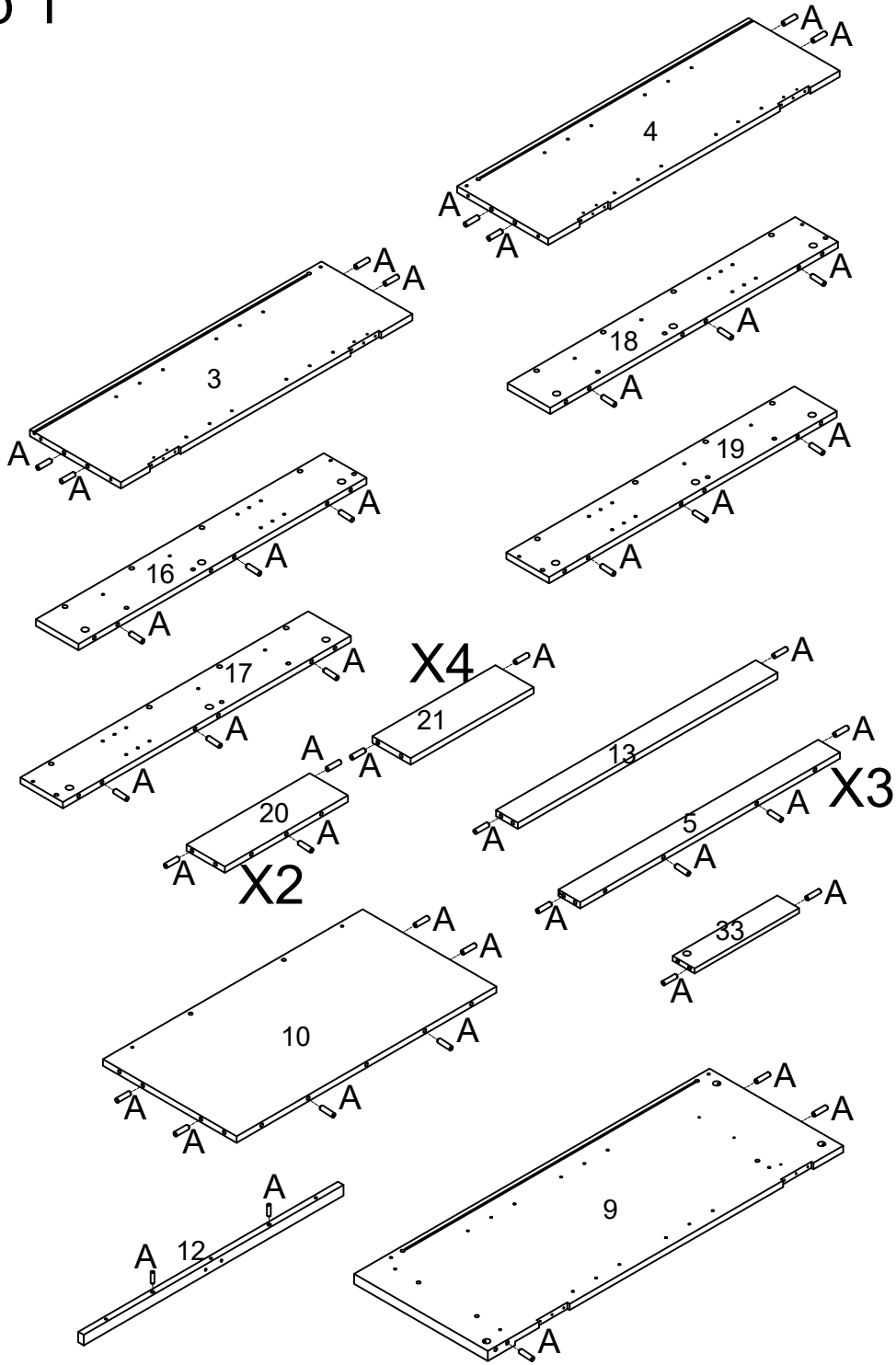

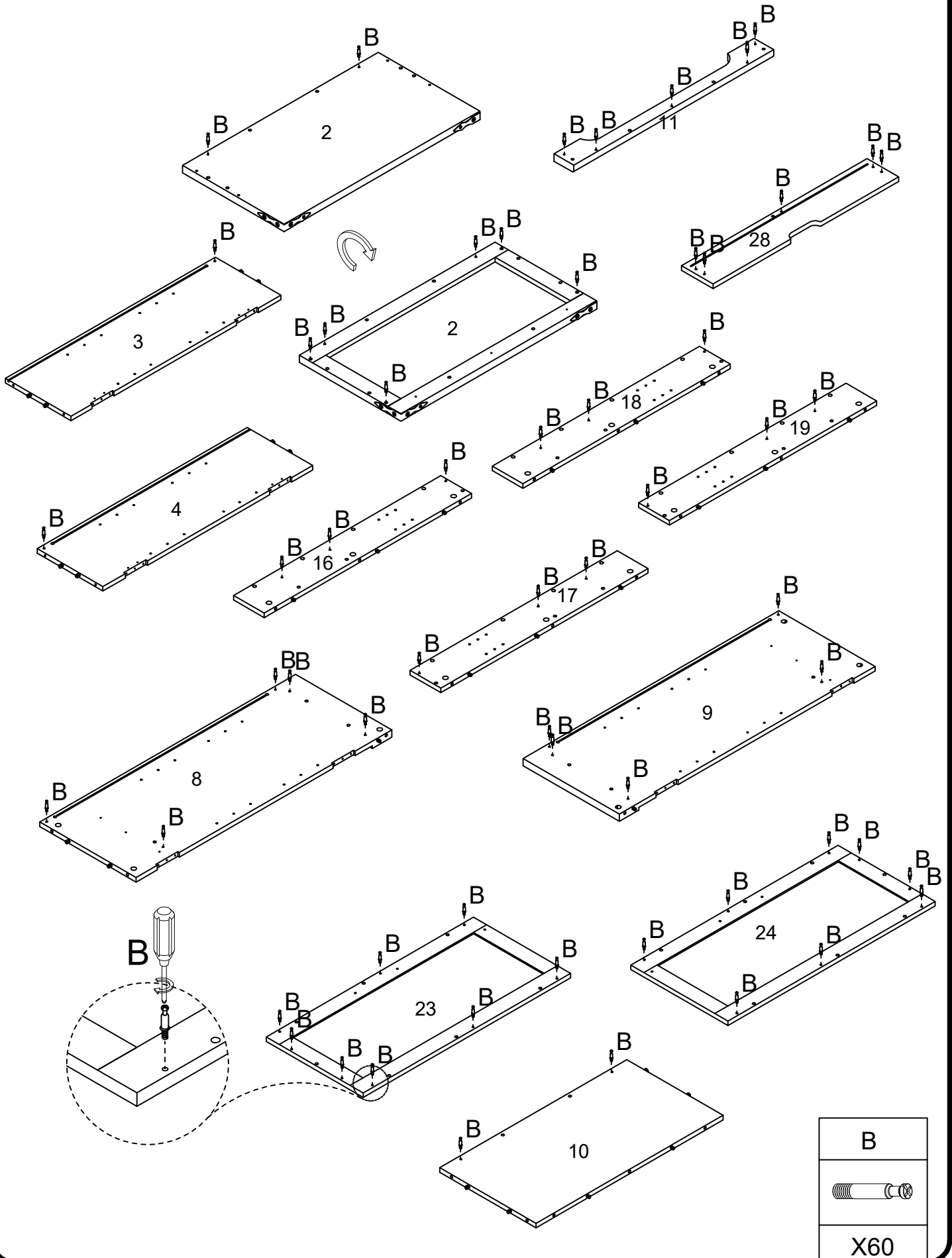

A

X64

Step 2

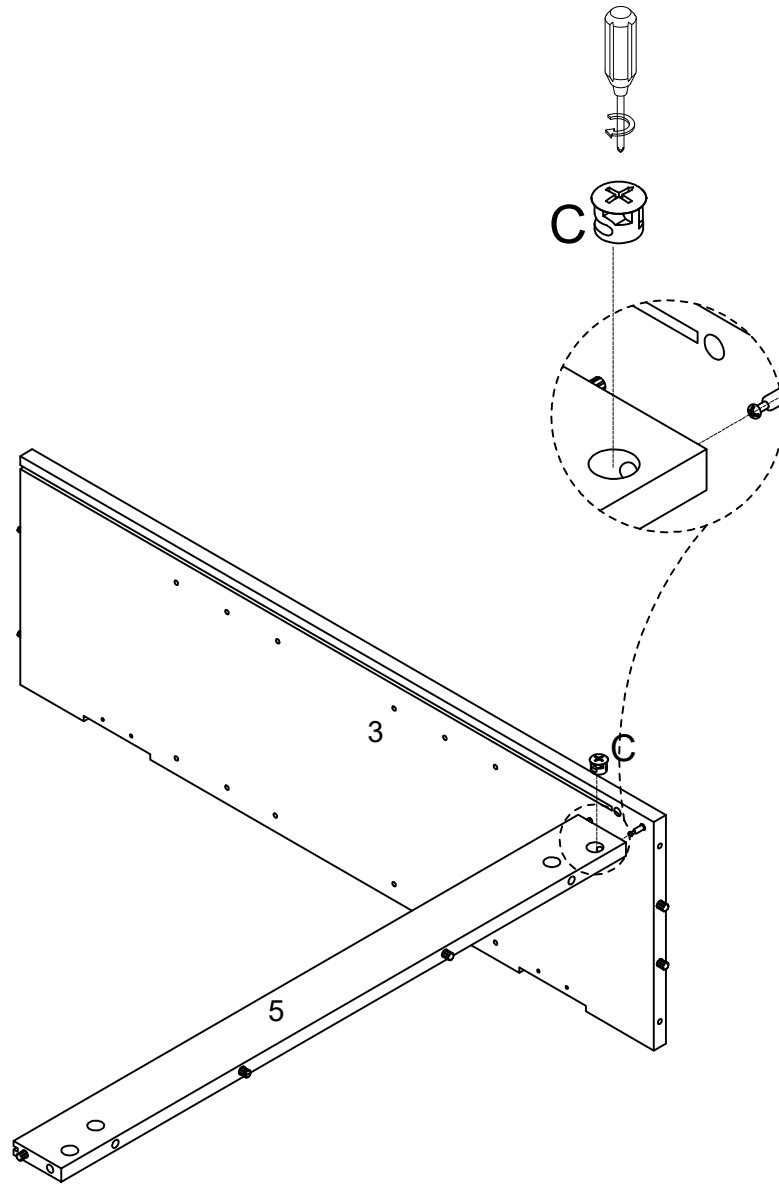
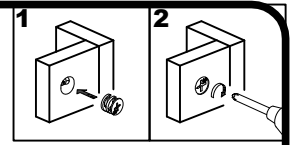



Step 3

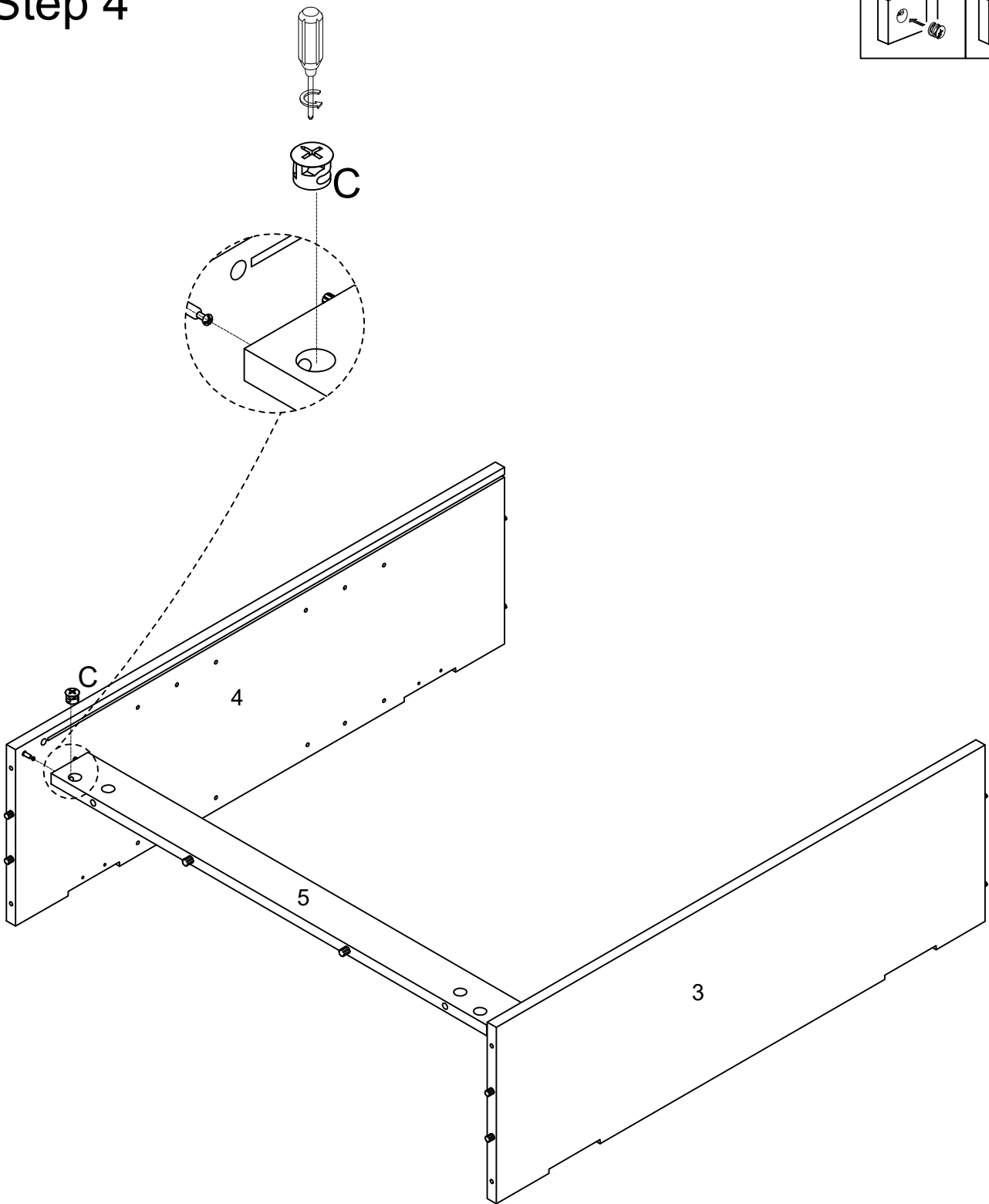
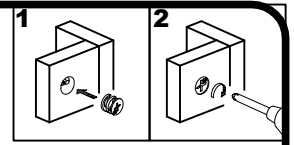

C

X1

Step 4



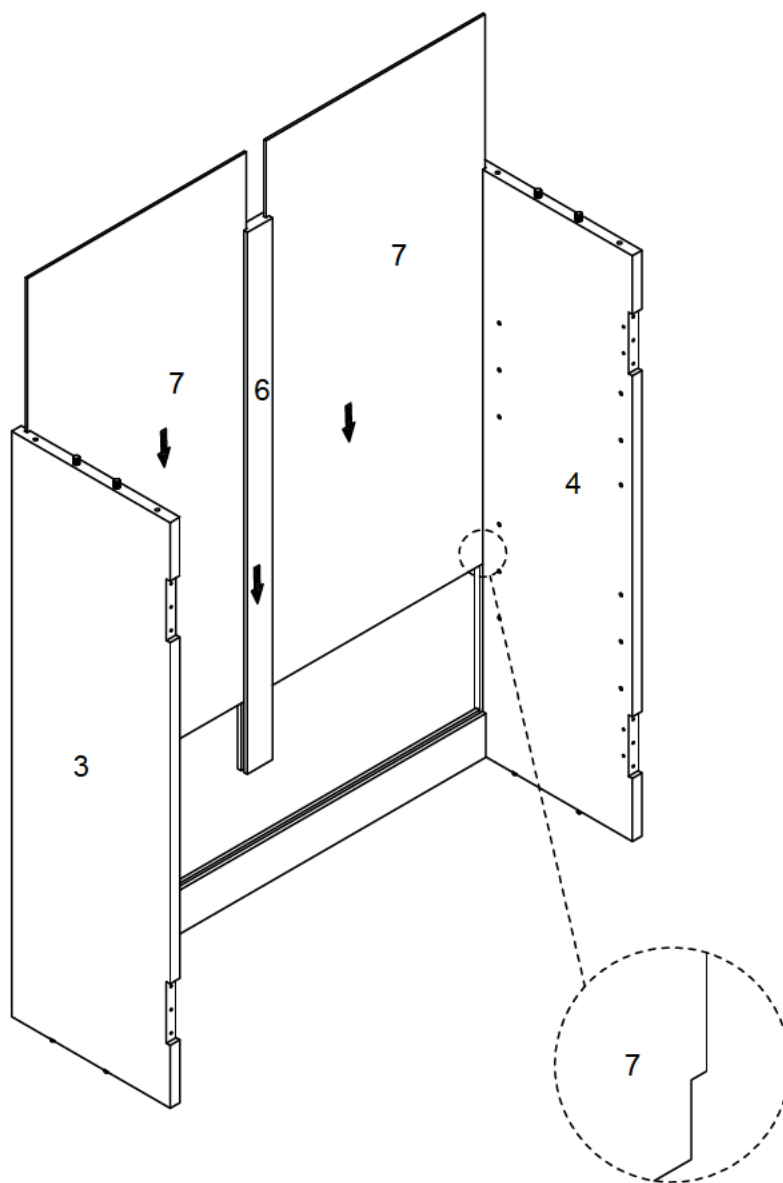

C

X1

Step 5

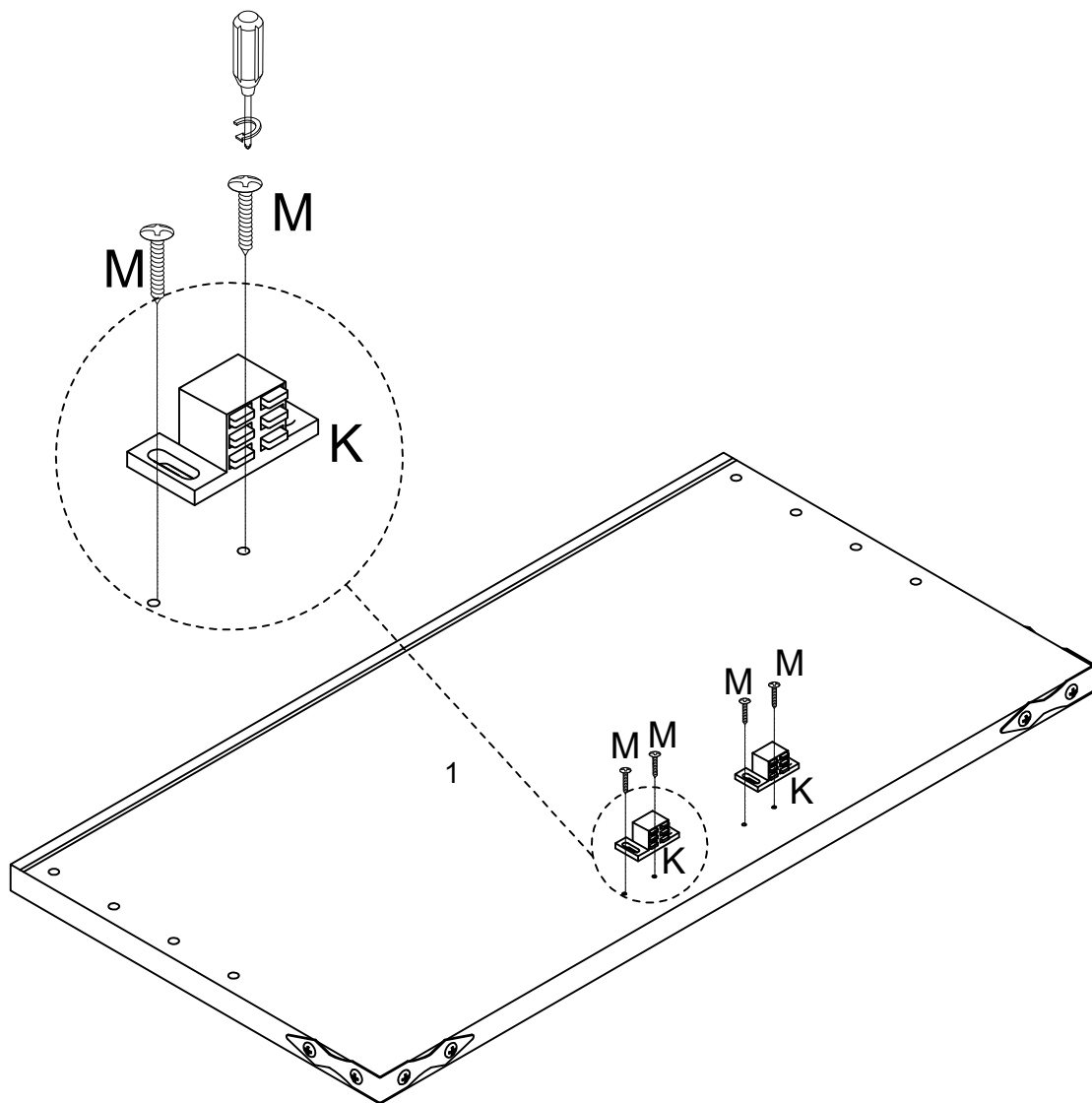



Step 6

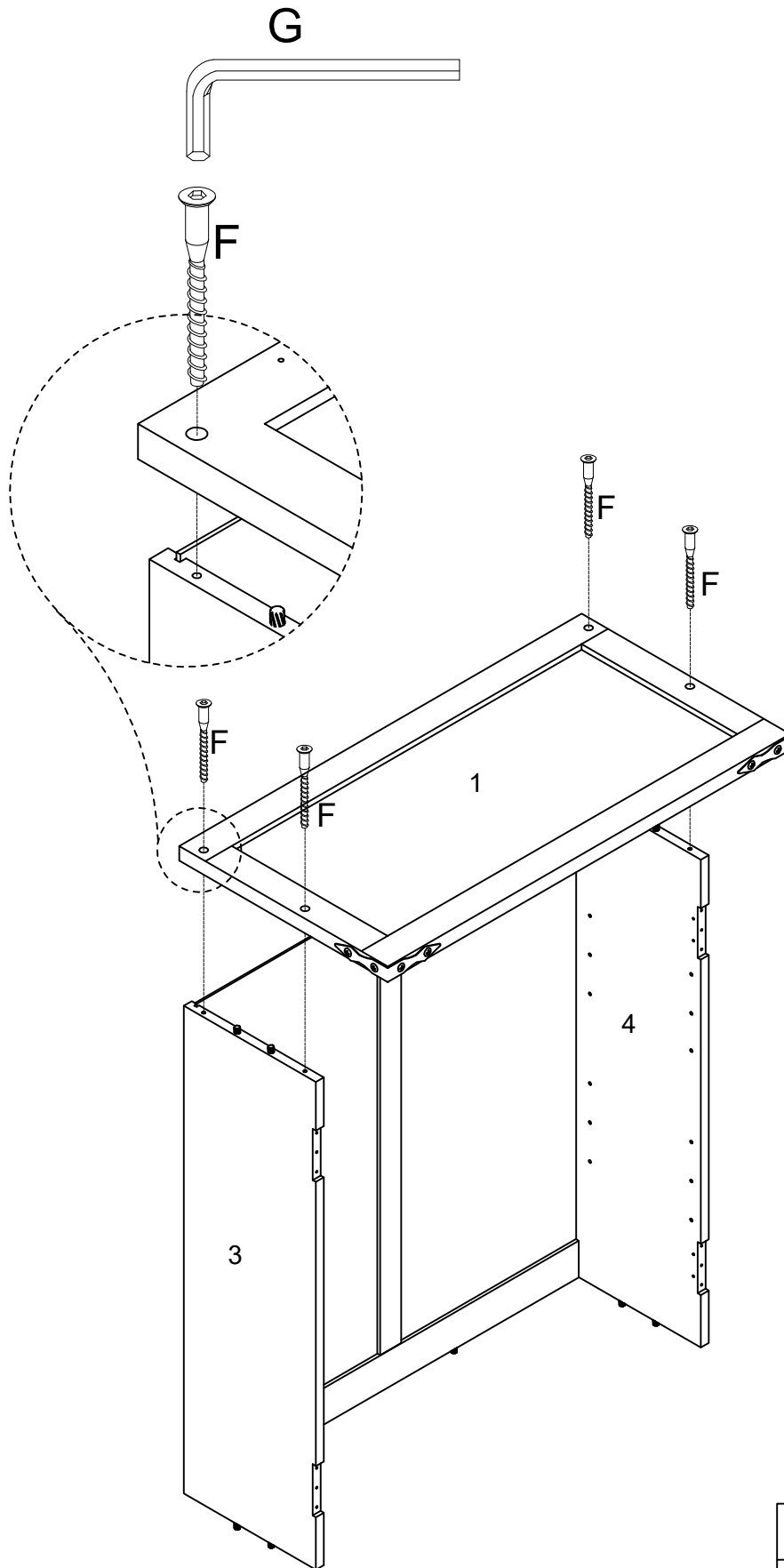

K	M
	
X2	X4

Step 7



F	G
	
X4	X1

Step 9



NOTE:

Refer to the images to identify Q-L (left) and Q-R (right). Attach Q-L to #8 panel and Q-R to #9 panel. [R] screws must go in the exact spots shown.

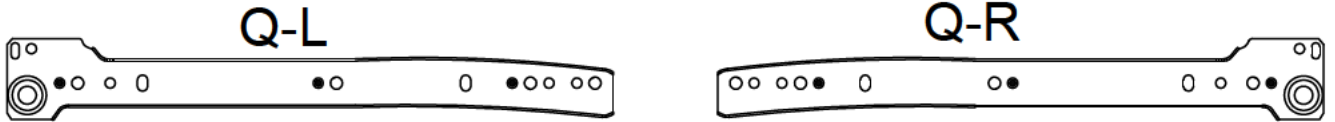

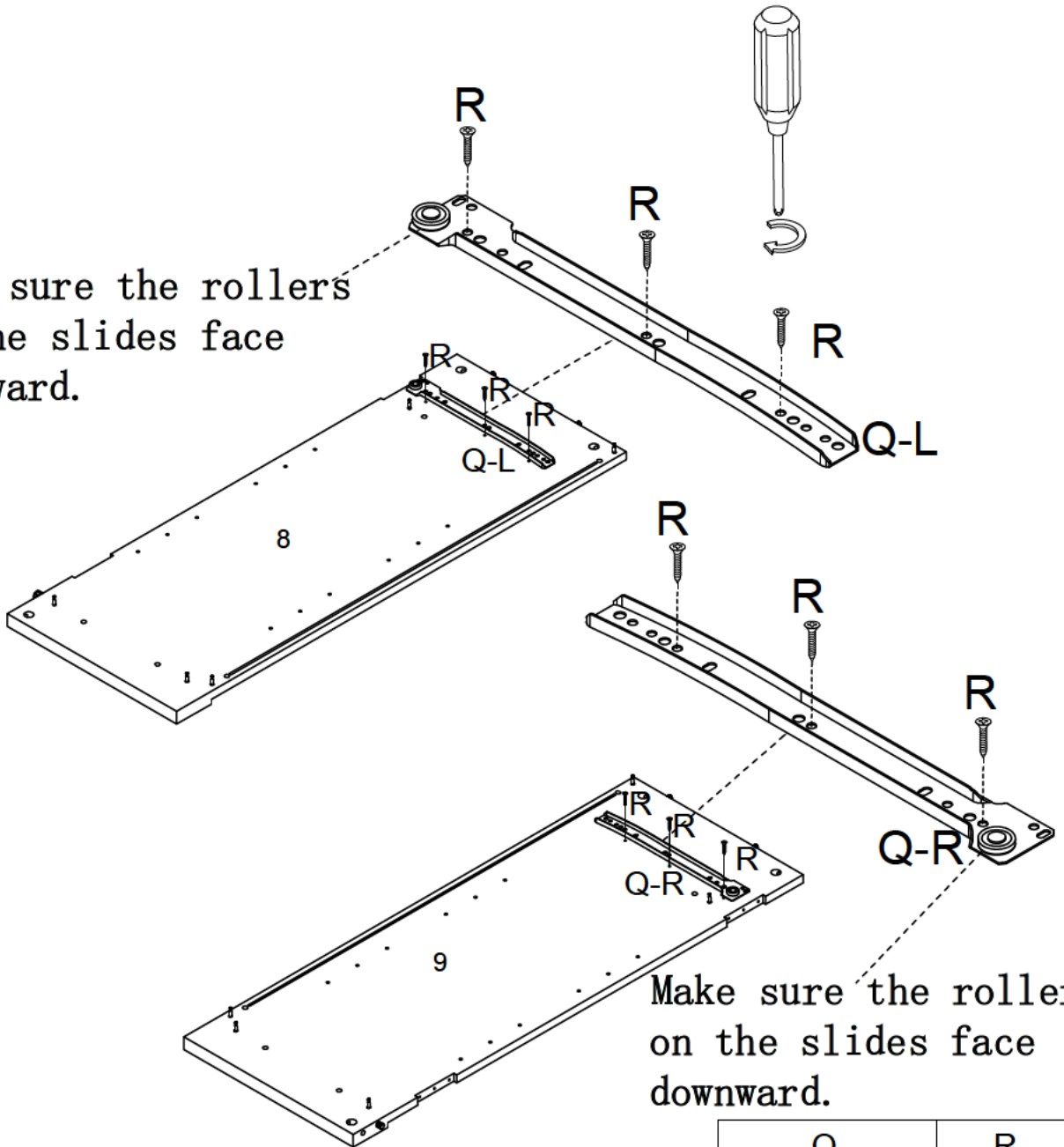

Make sure the rollers on the slides face downward.

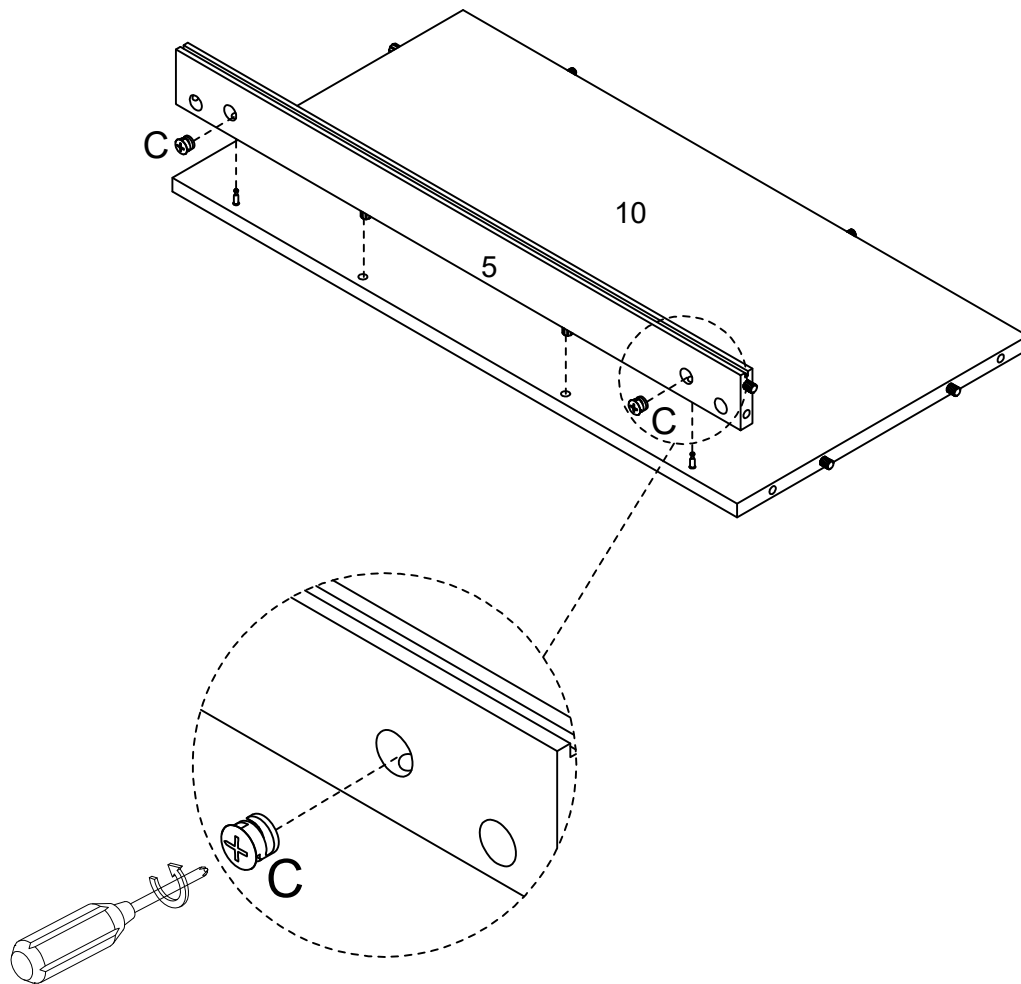
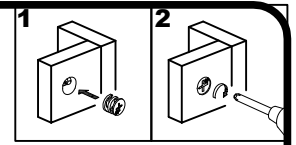

Q	R
X1	X6

Step 10



C

X2

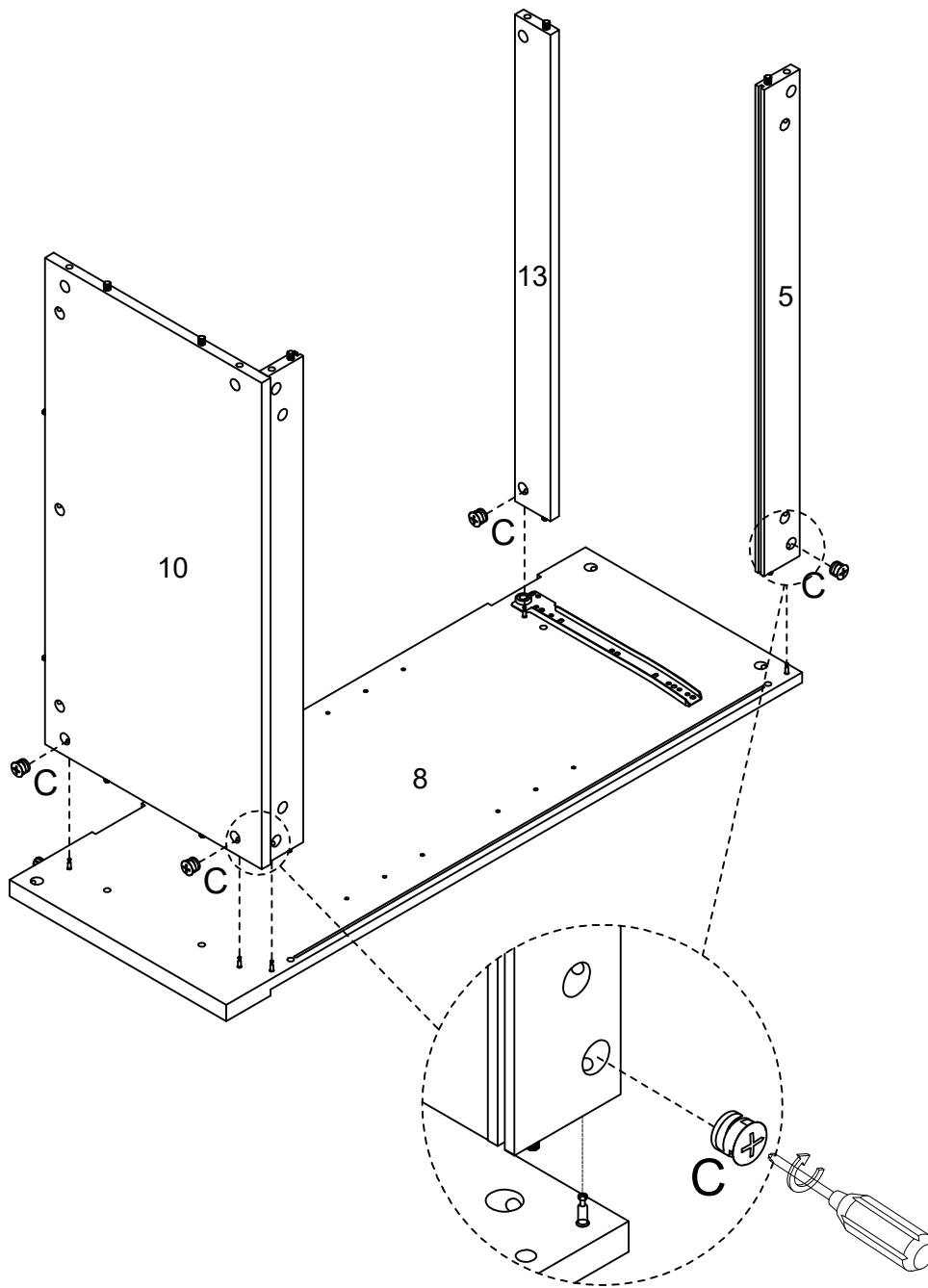
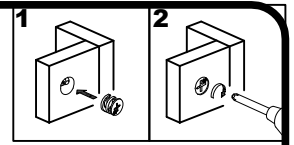
Step 11



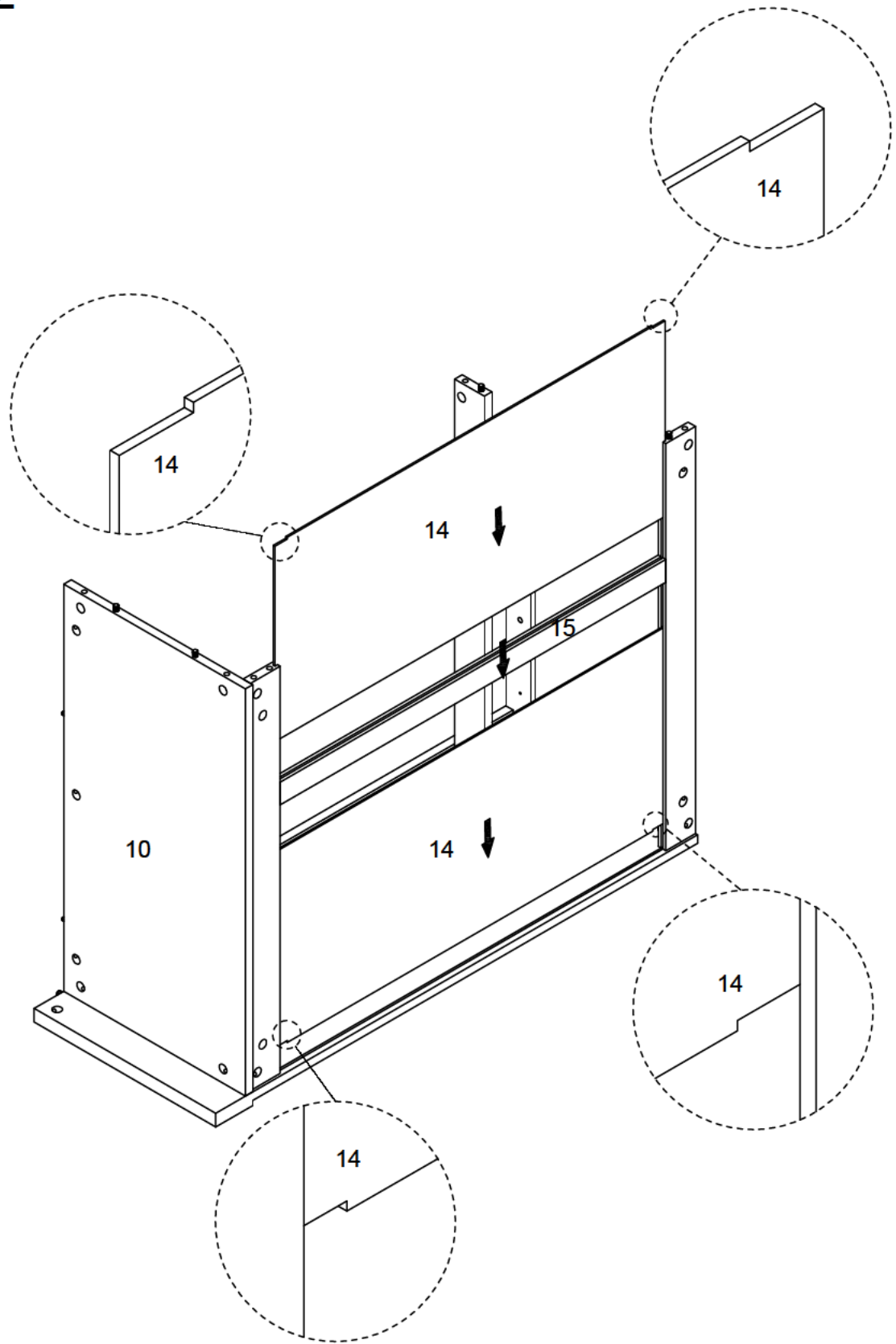

C

X5

Step 12

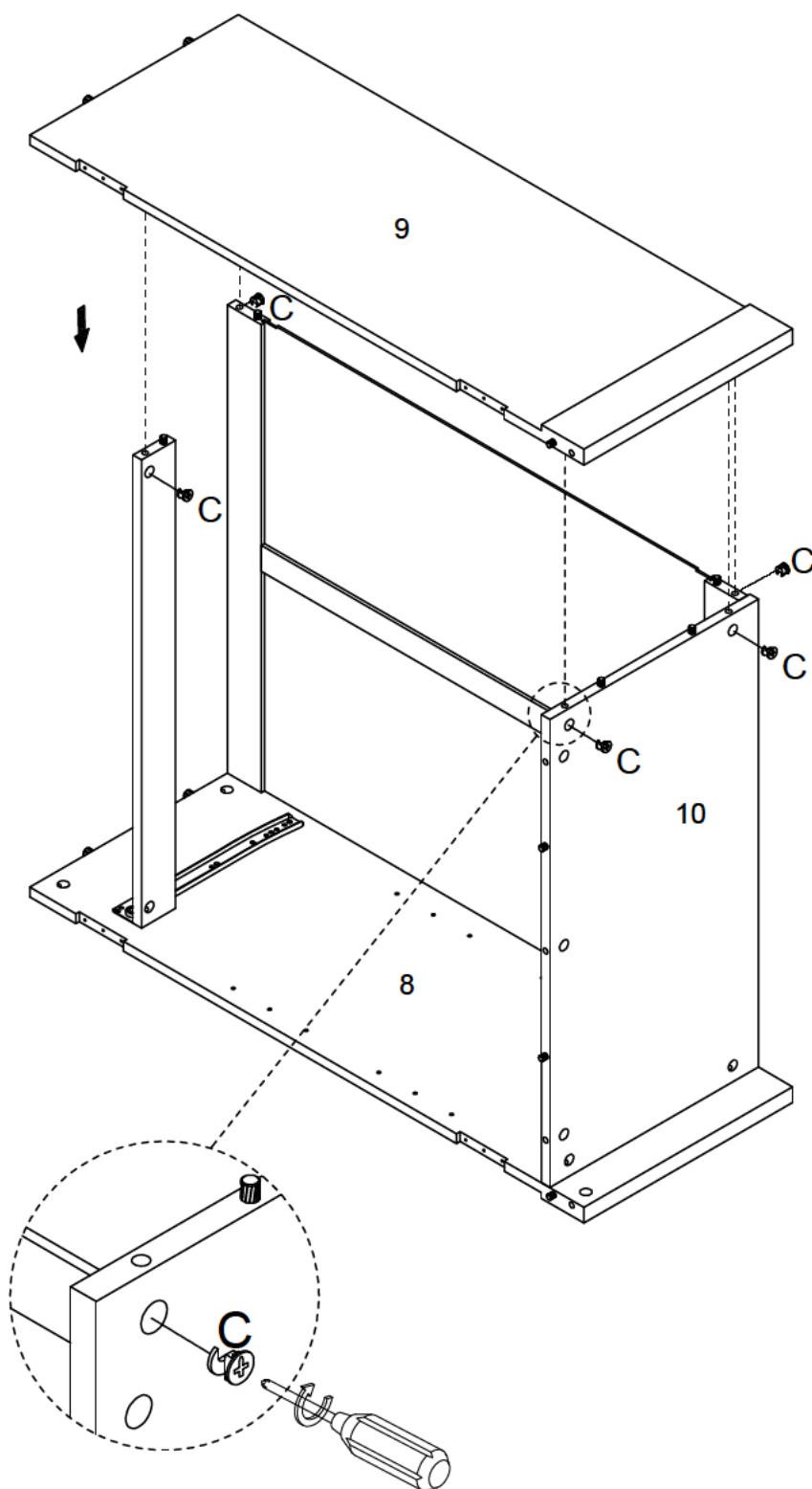
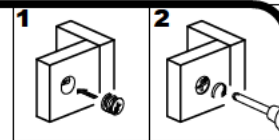



Step 13

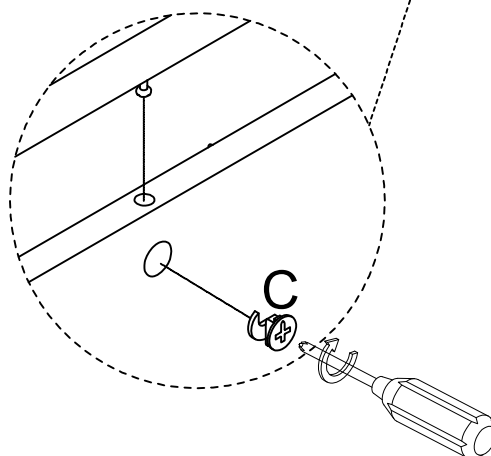
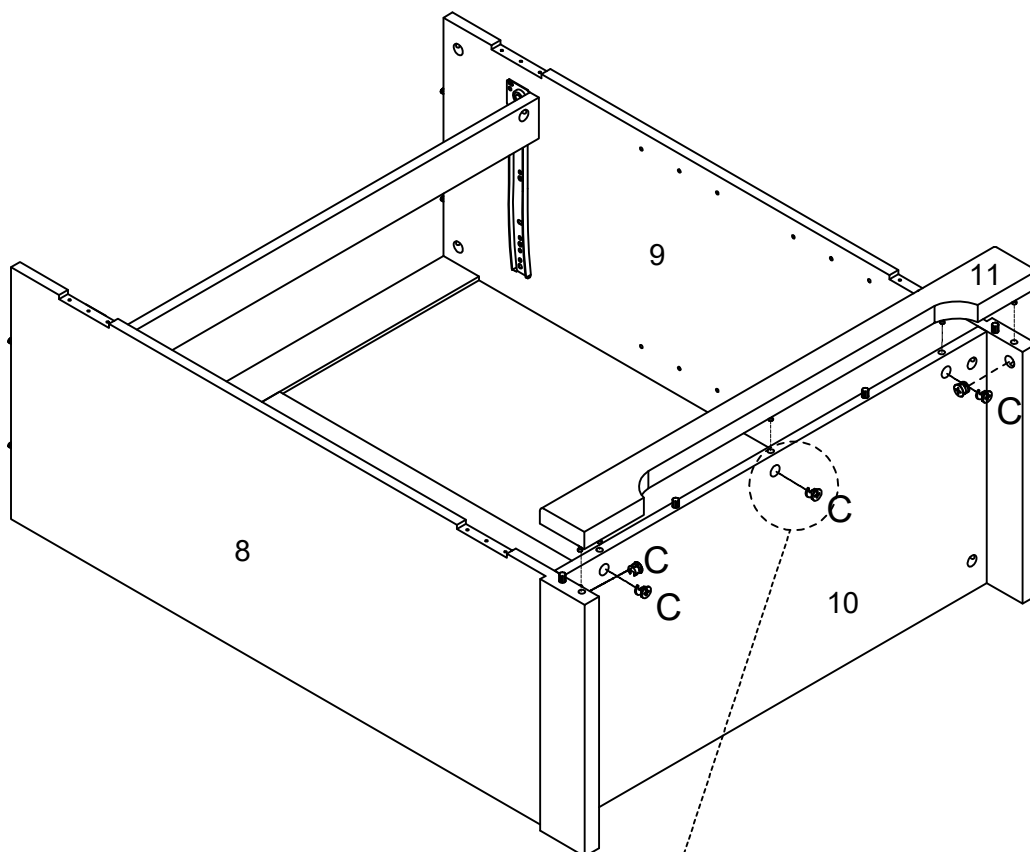
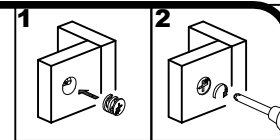

C

X5

Step 14

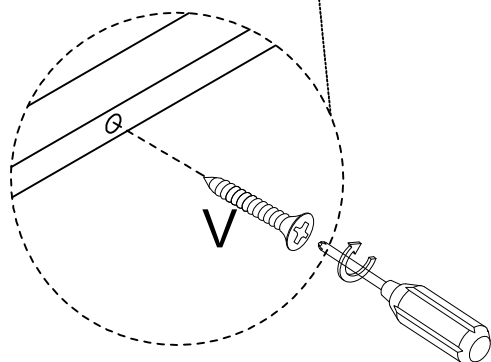
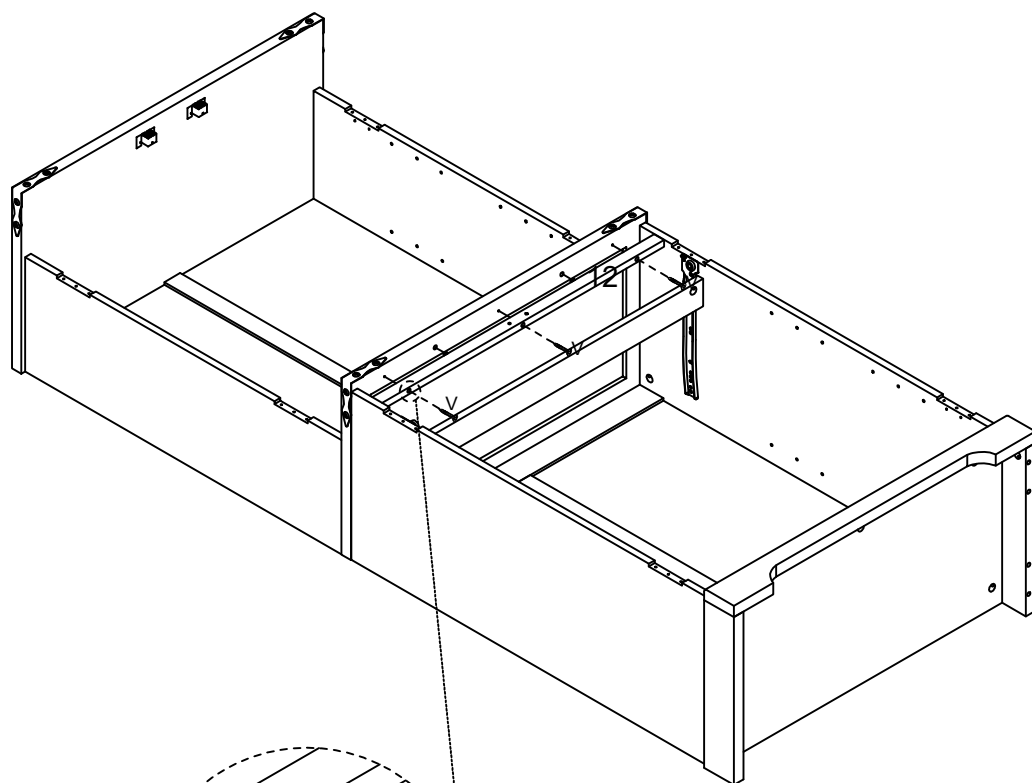

C

X5

Step 16

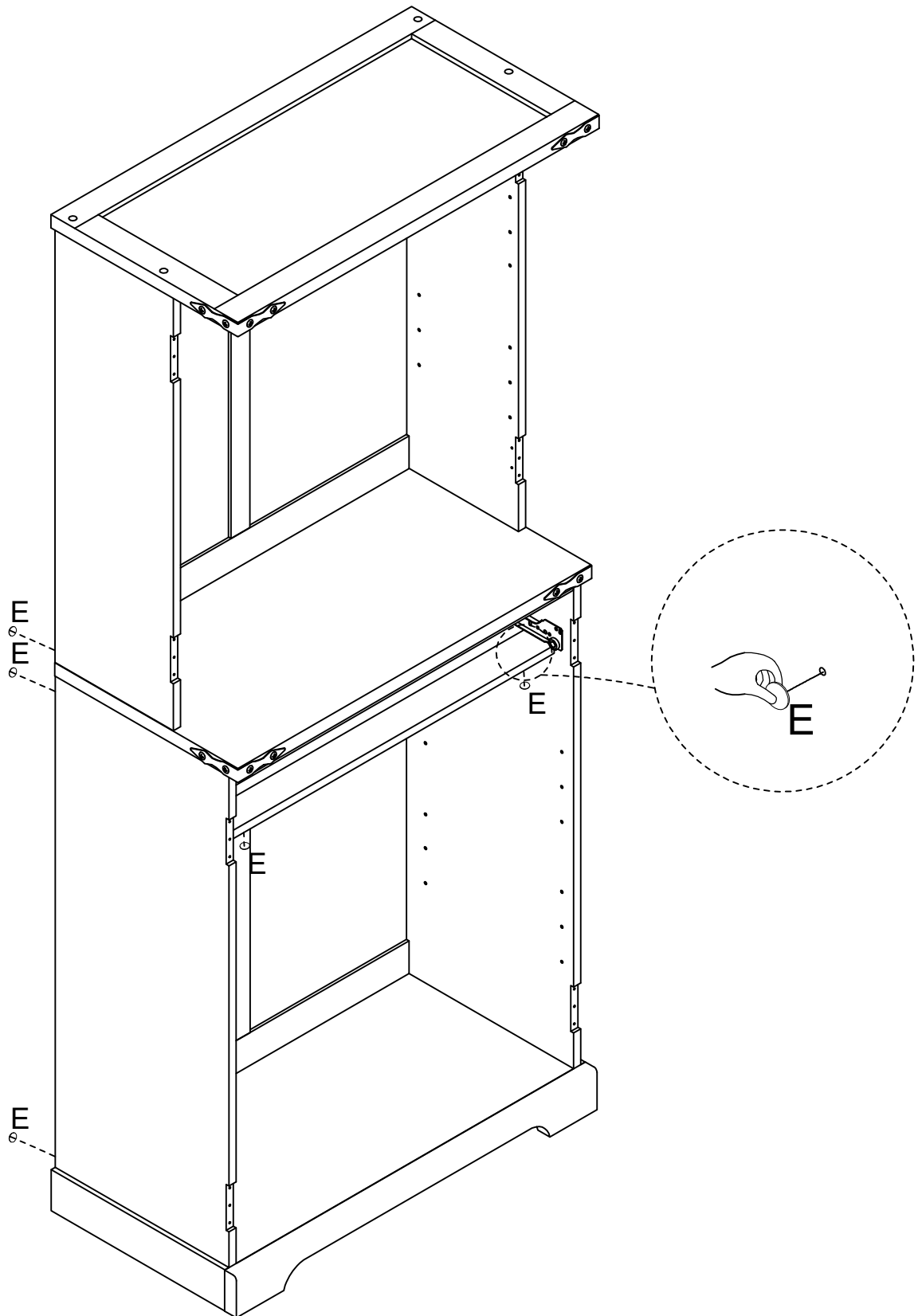

V

X3

Step 17

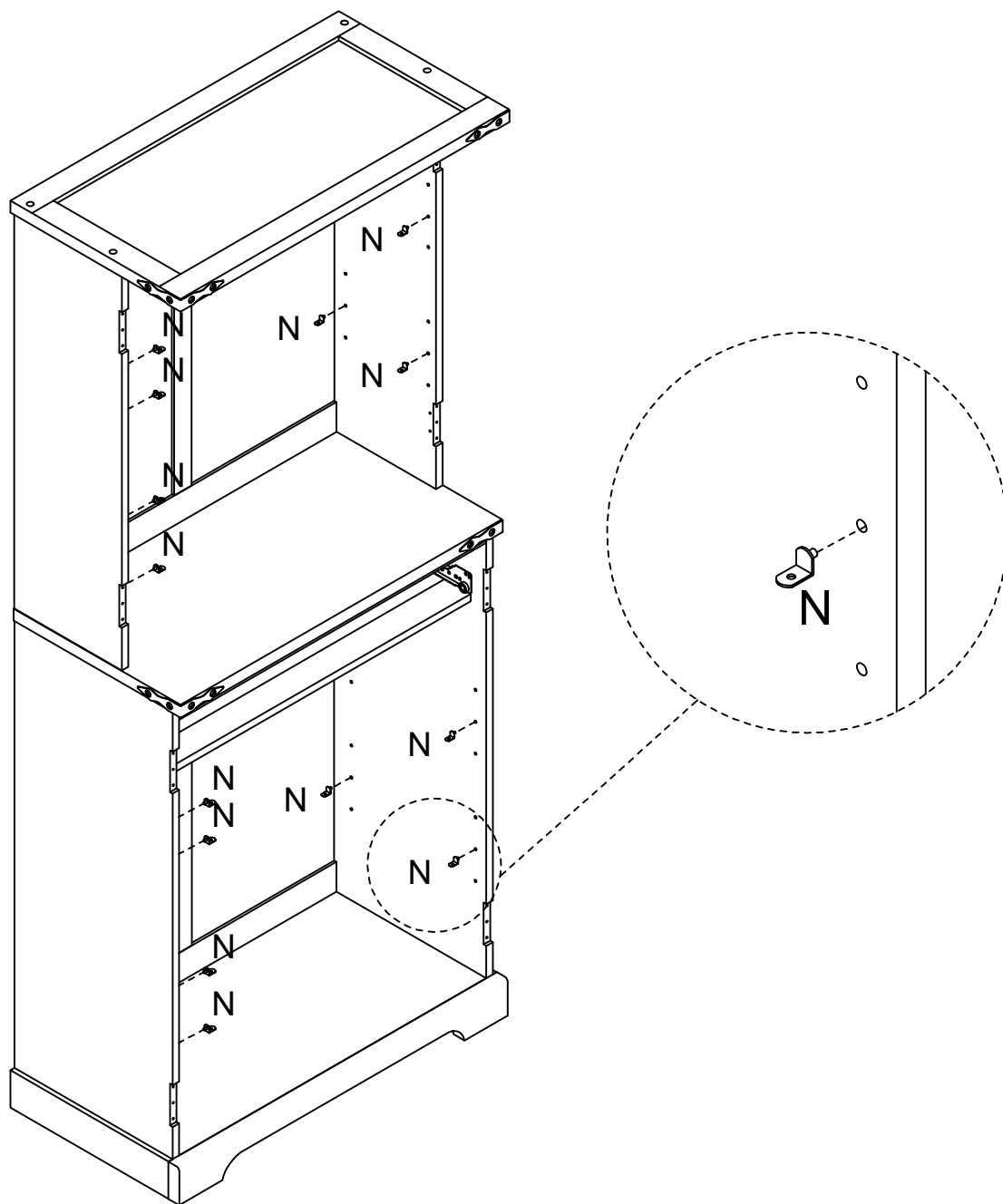

E

X27

Step 18



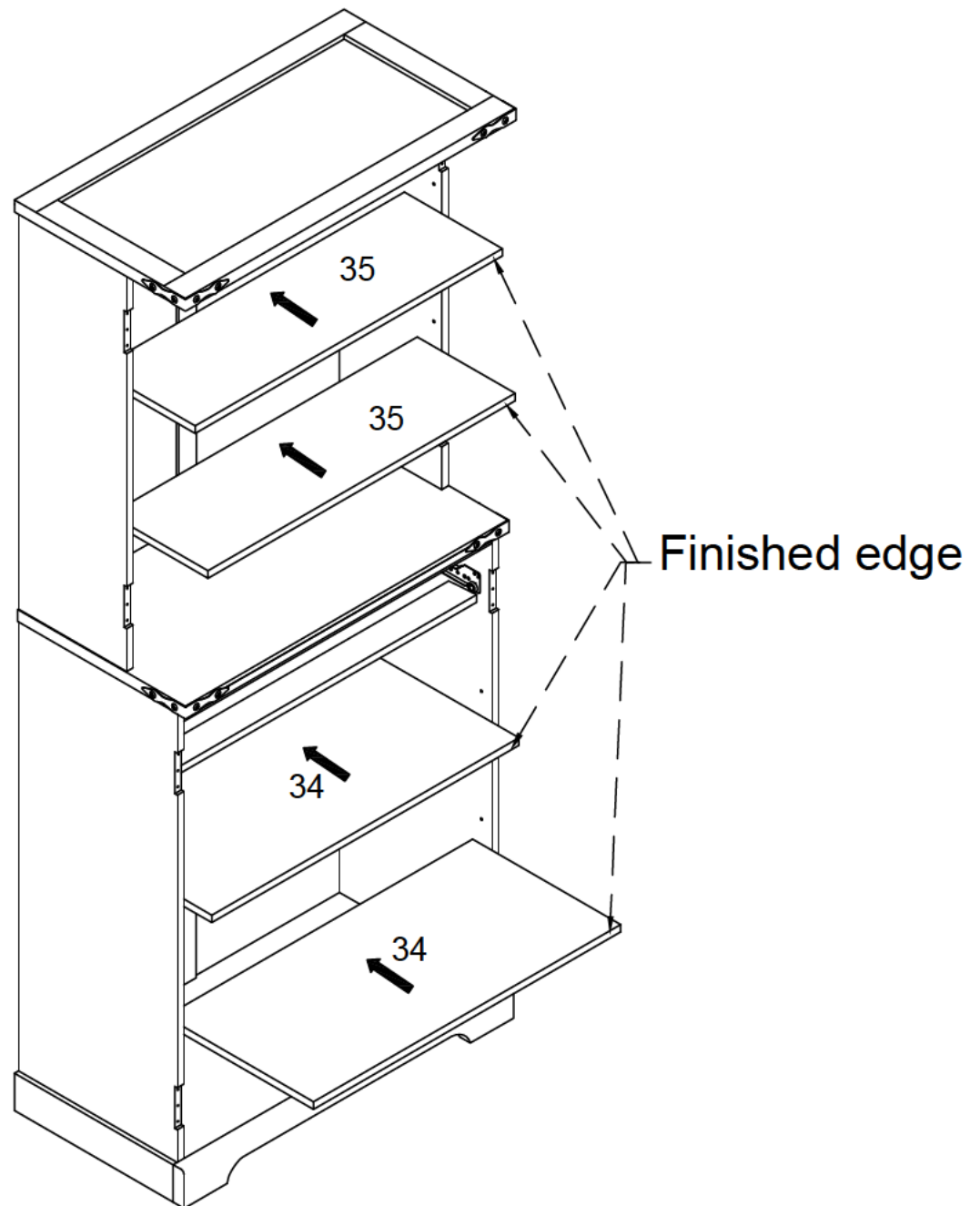

N

X16

Step 19

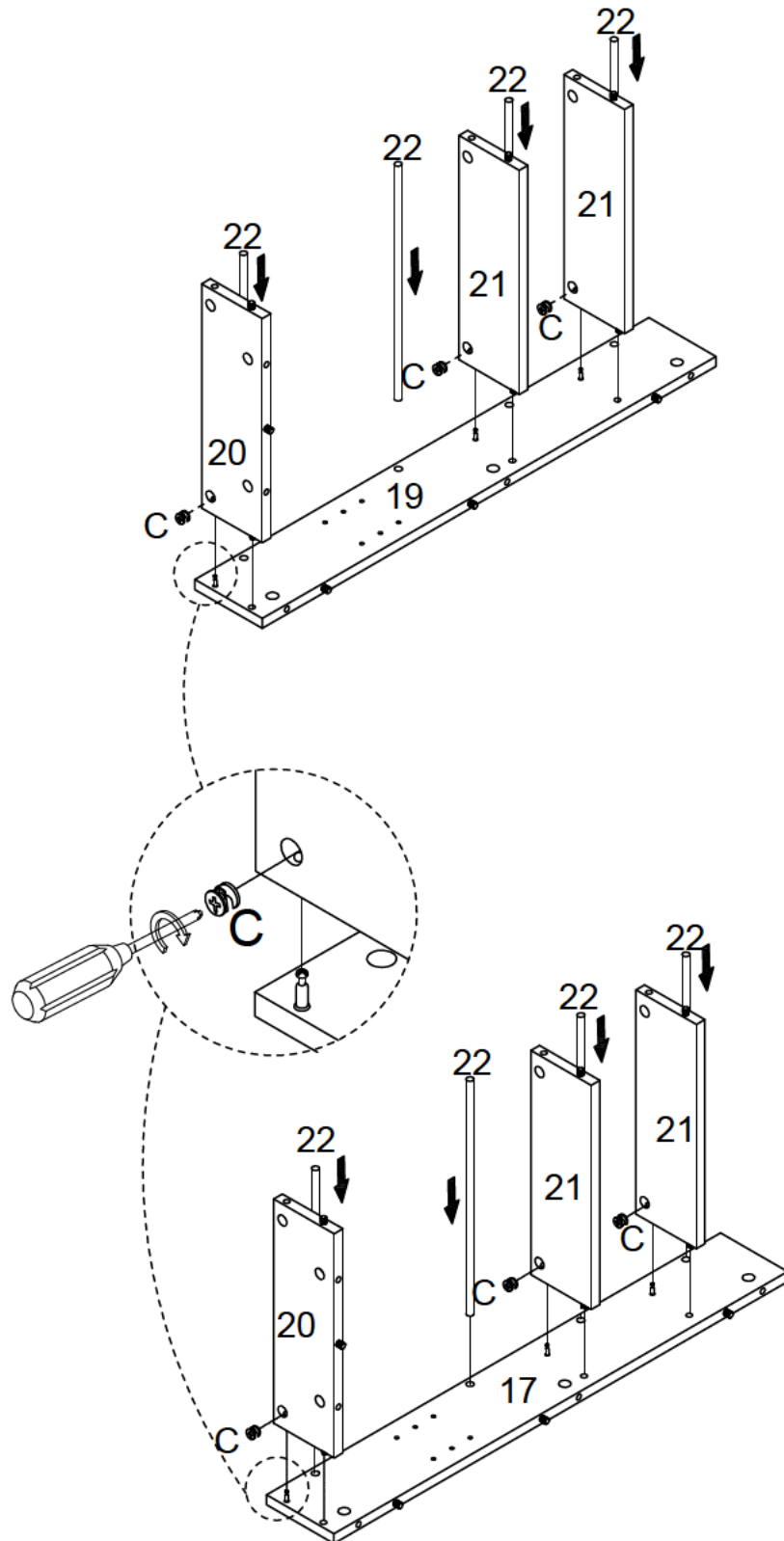
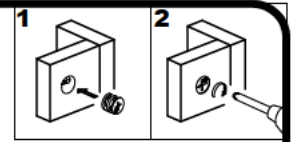



Step 20

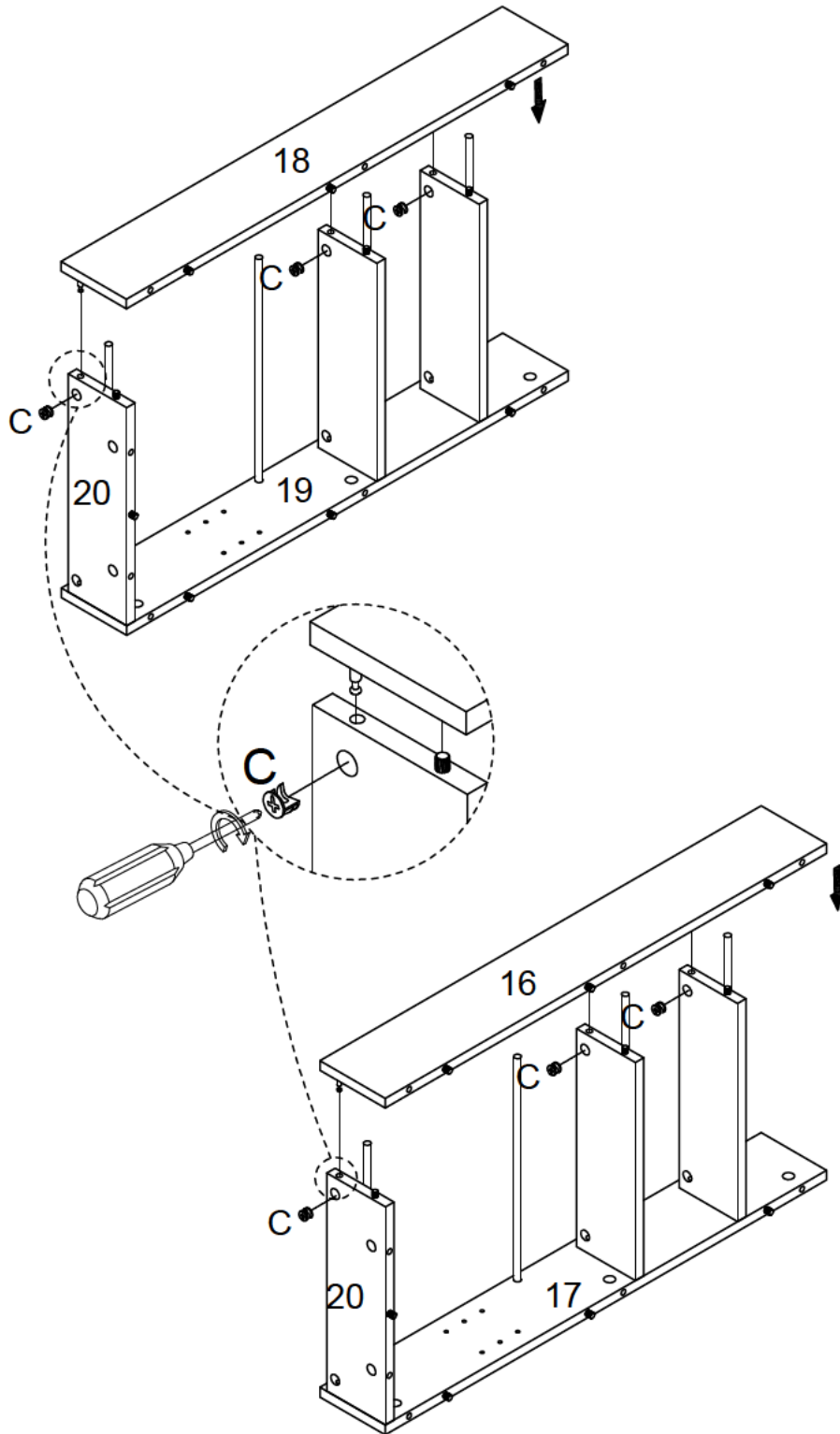
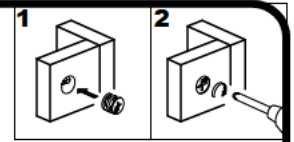

C

X6

Step 21

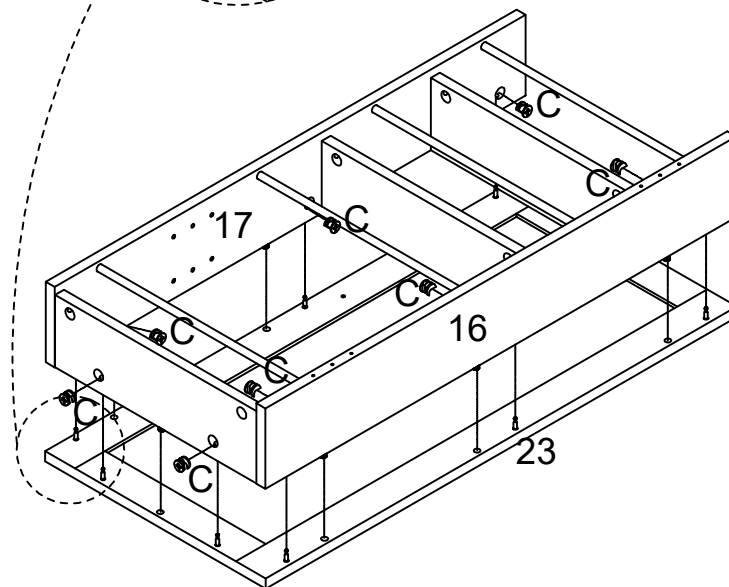
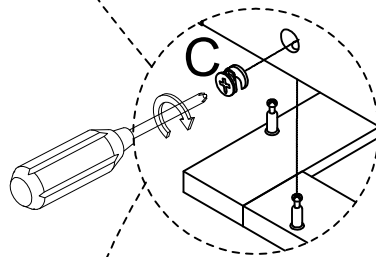
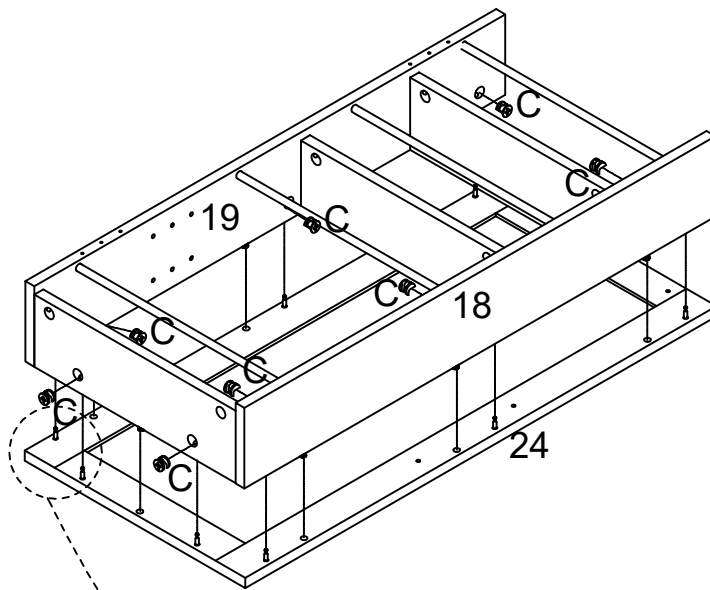
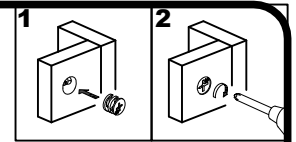

C

X6



Step 22

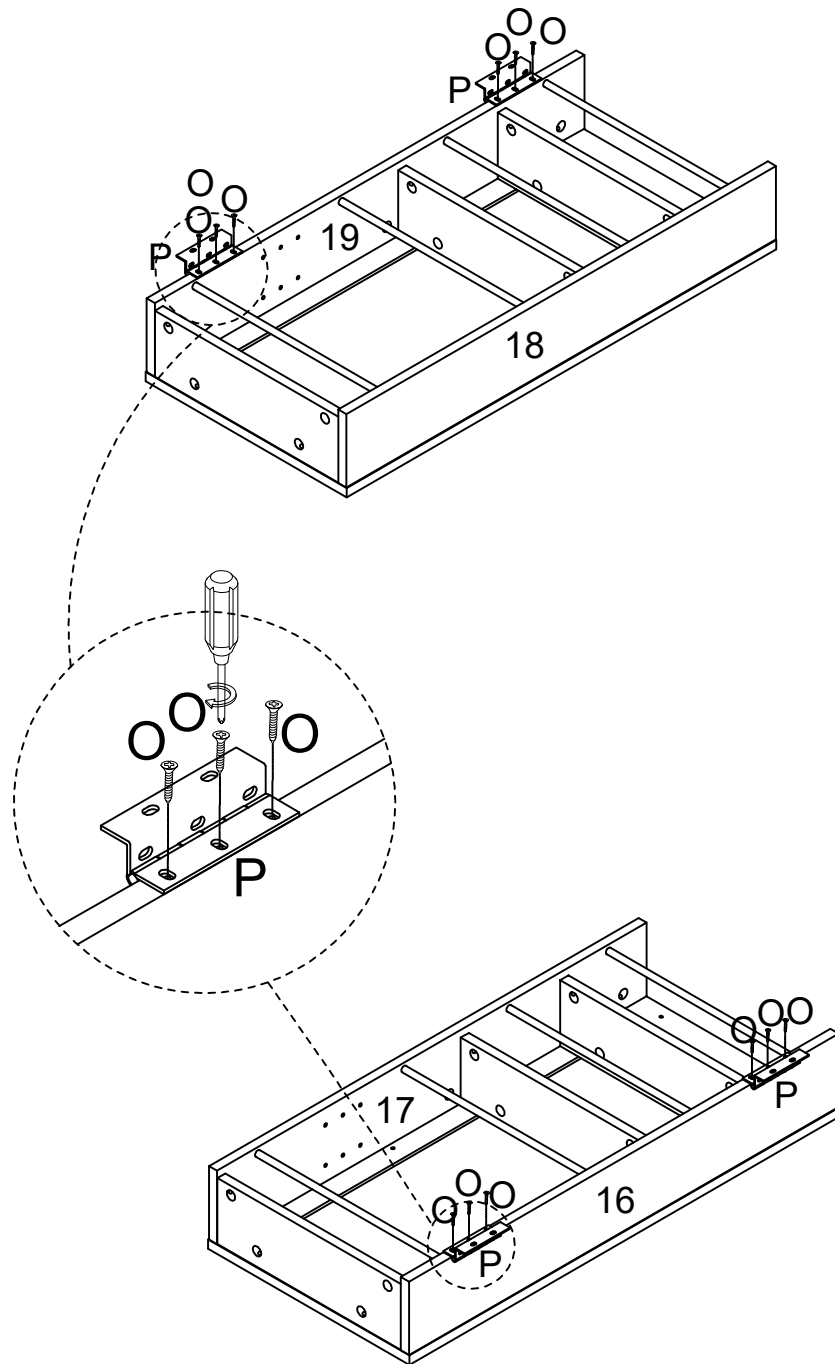

C

X16





Step 23

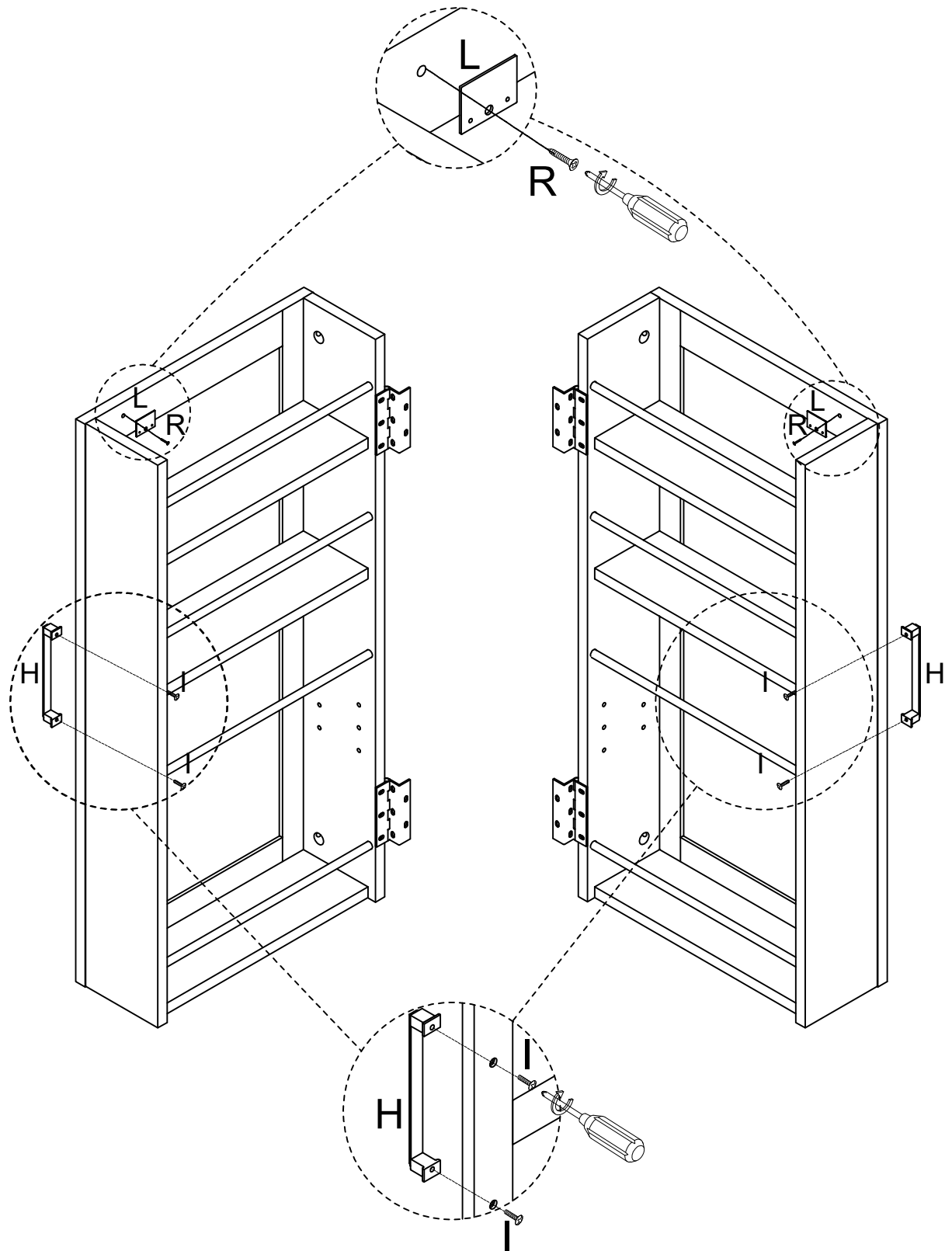

O	P
	
X12	X4

Step 24



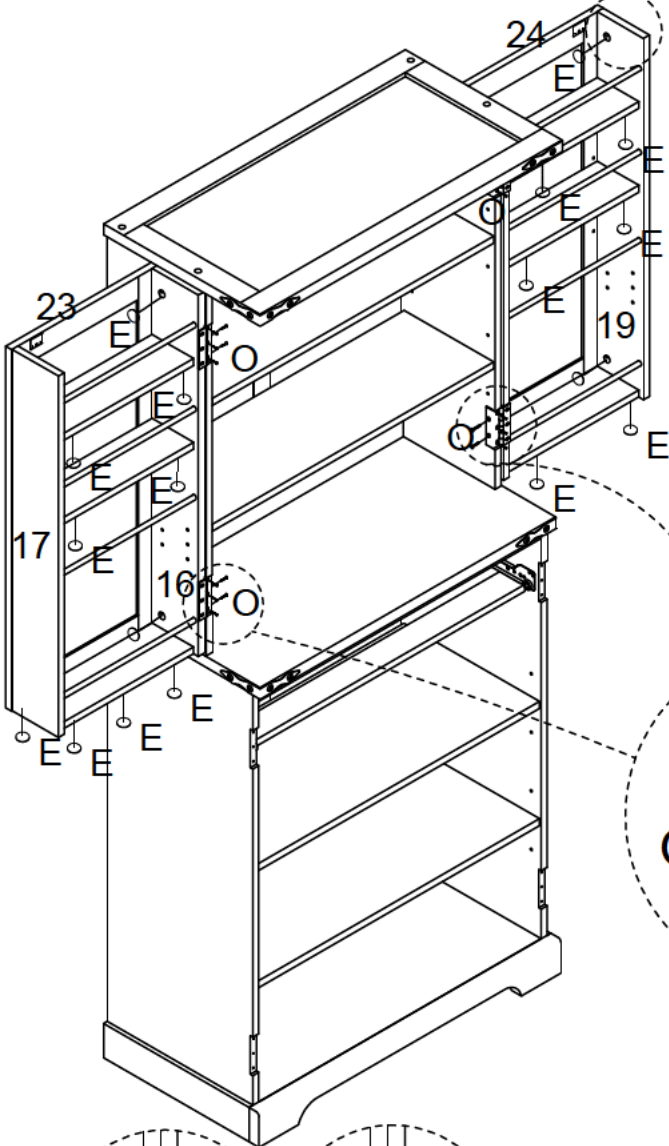
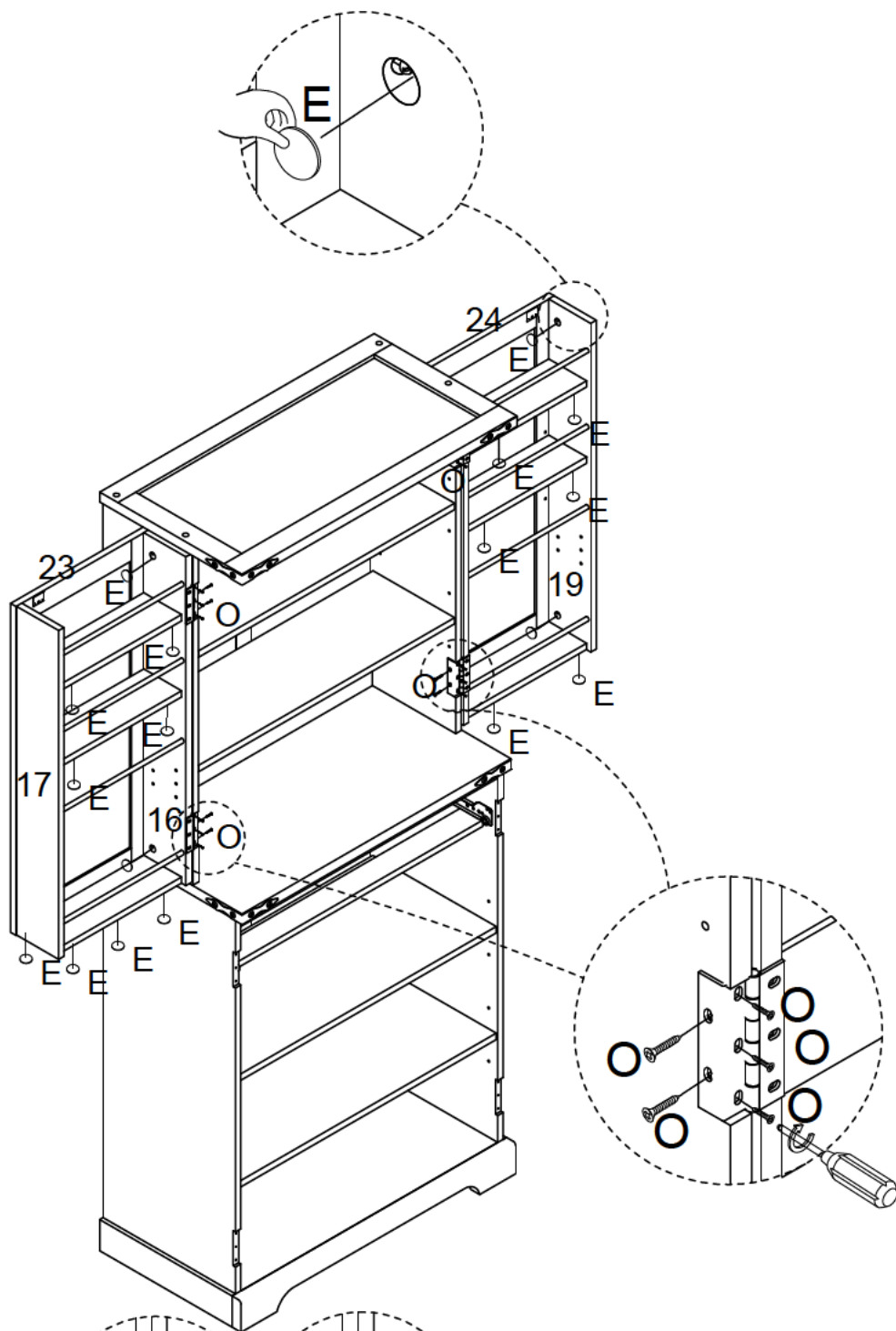

H	I	L	R
			
X2	X4	X2	X2

Step 25



Loose screws can be adjusted left or right

Loose screws can be adjusted up and down

E	O
	
X28	X20

Step 26

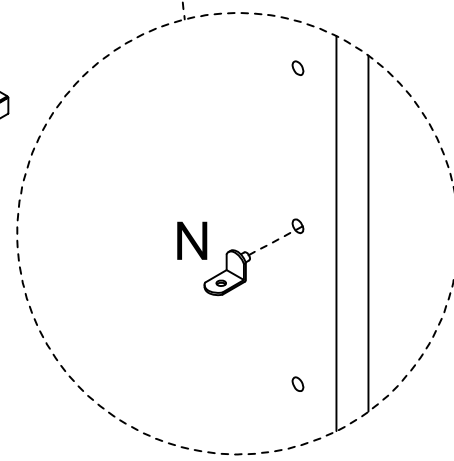
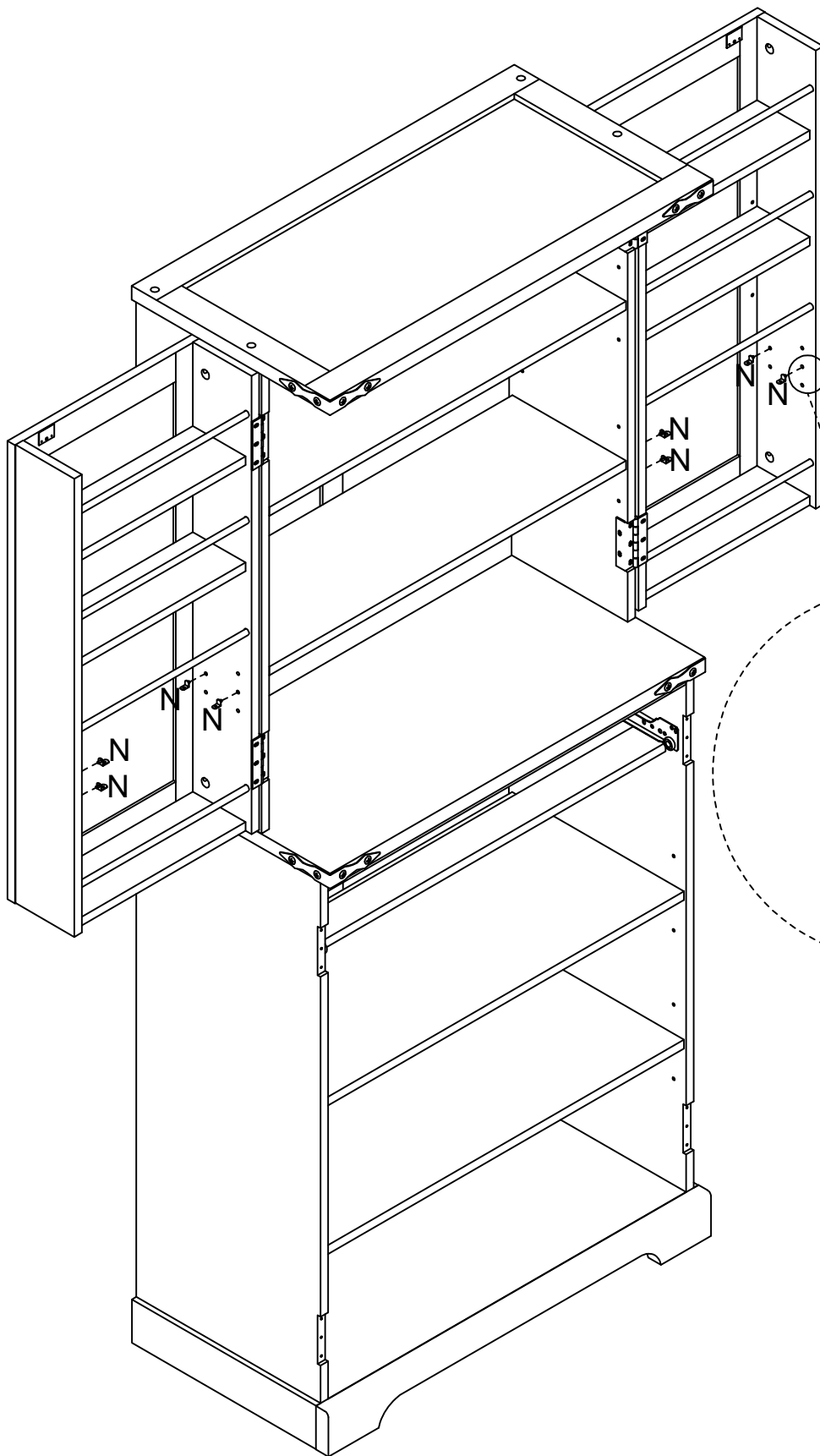

N
X8

Step 27

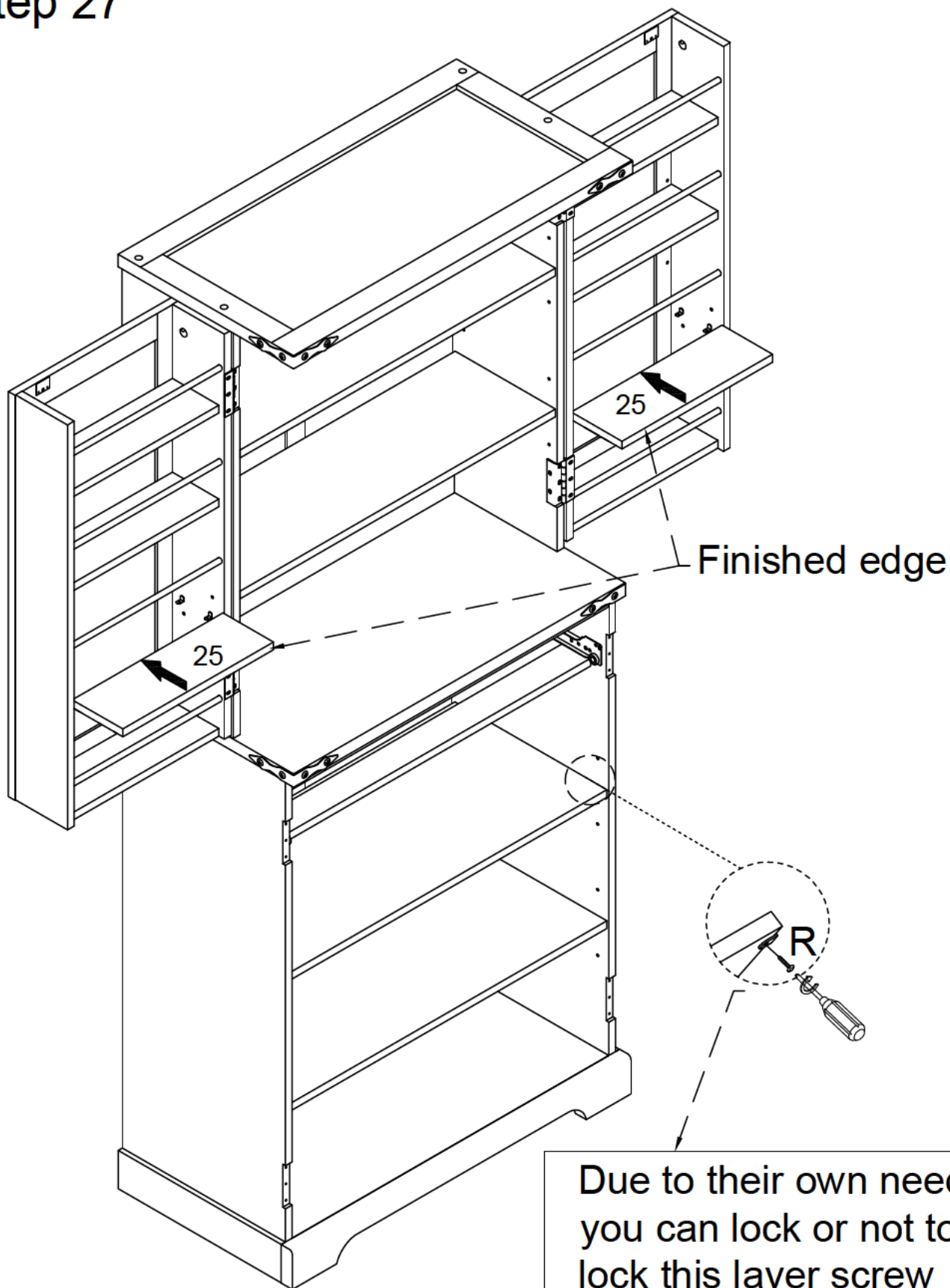

Due to their own needs,
you can lock or not to
lock this layer screw

R

X12

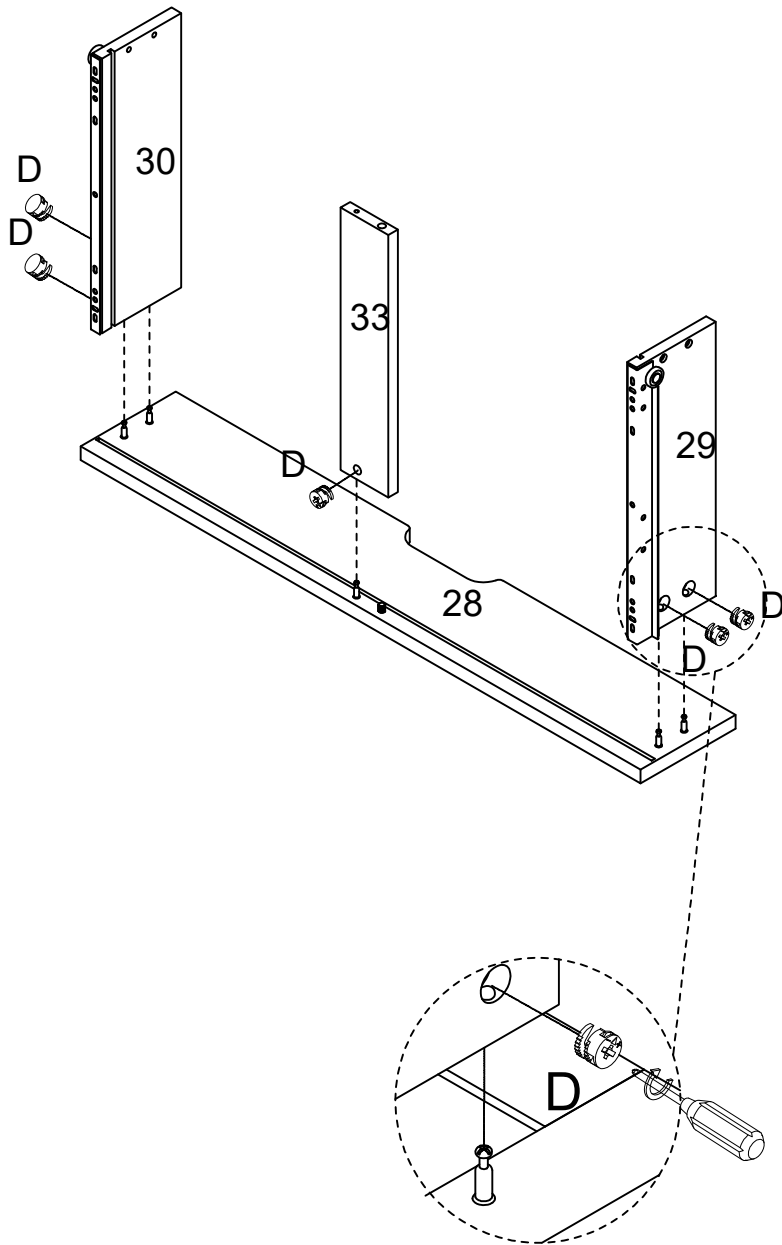
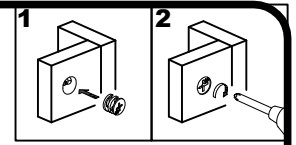
Step 28



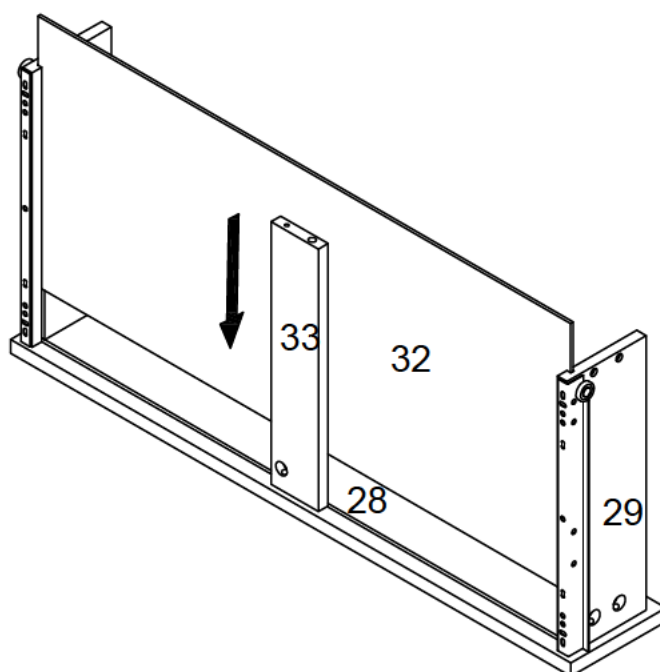
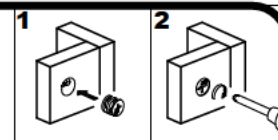

D

X5

Step 29

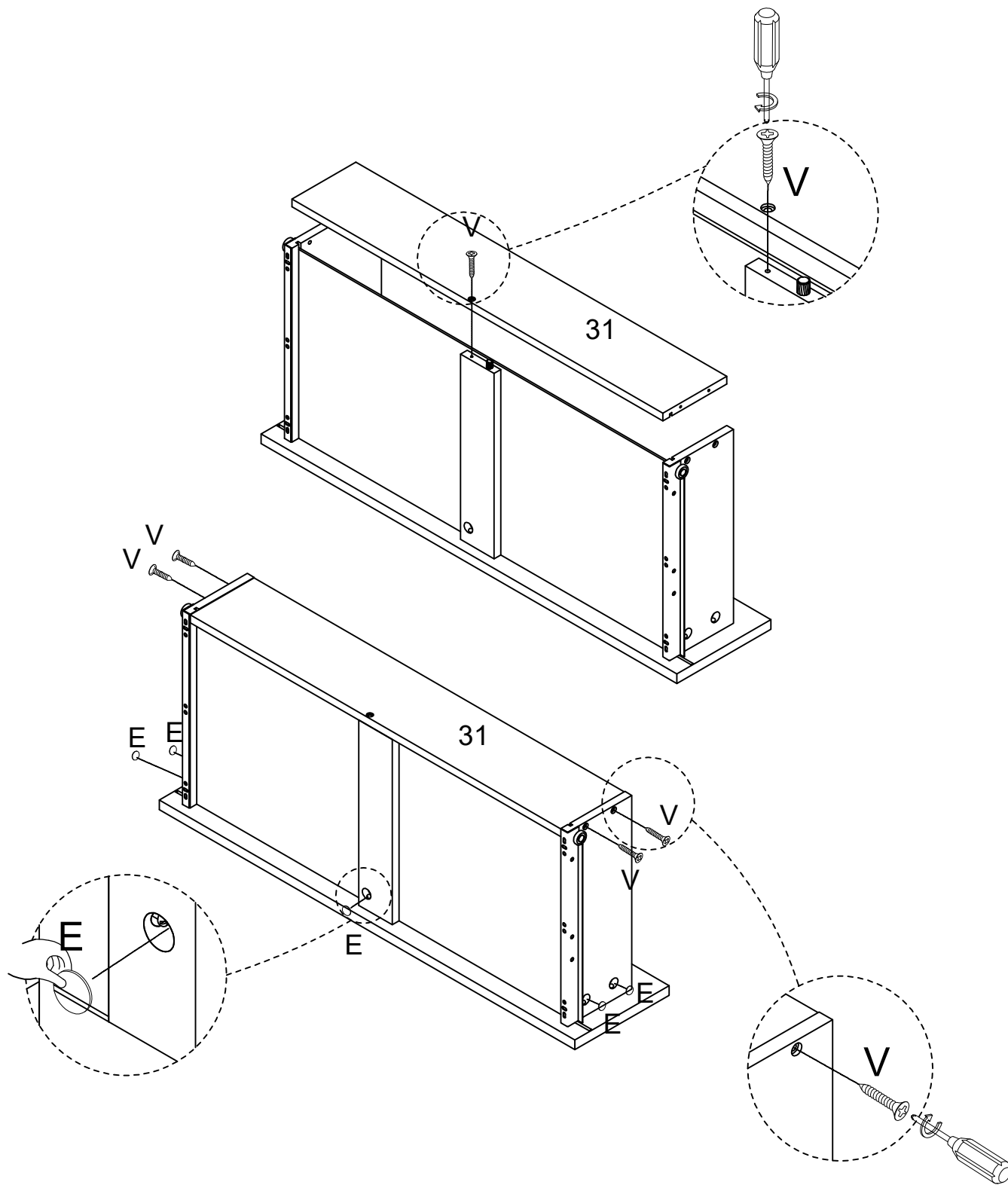



Step 30



E	V
	
X5	X5

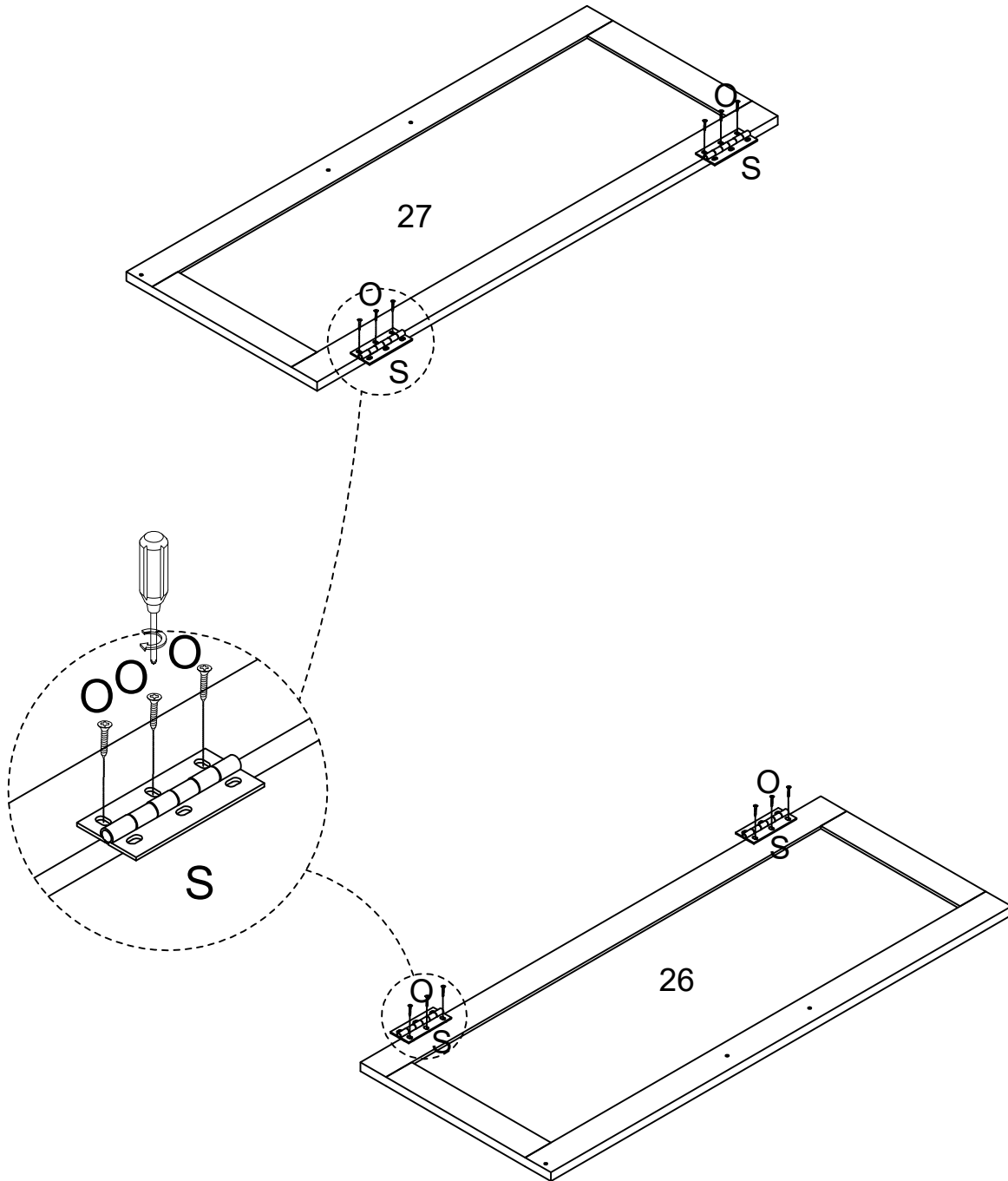

Step 31

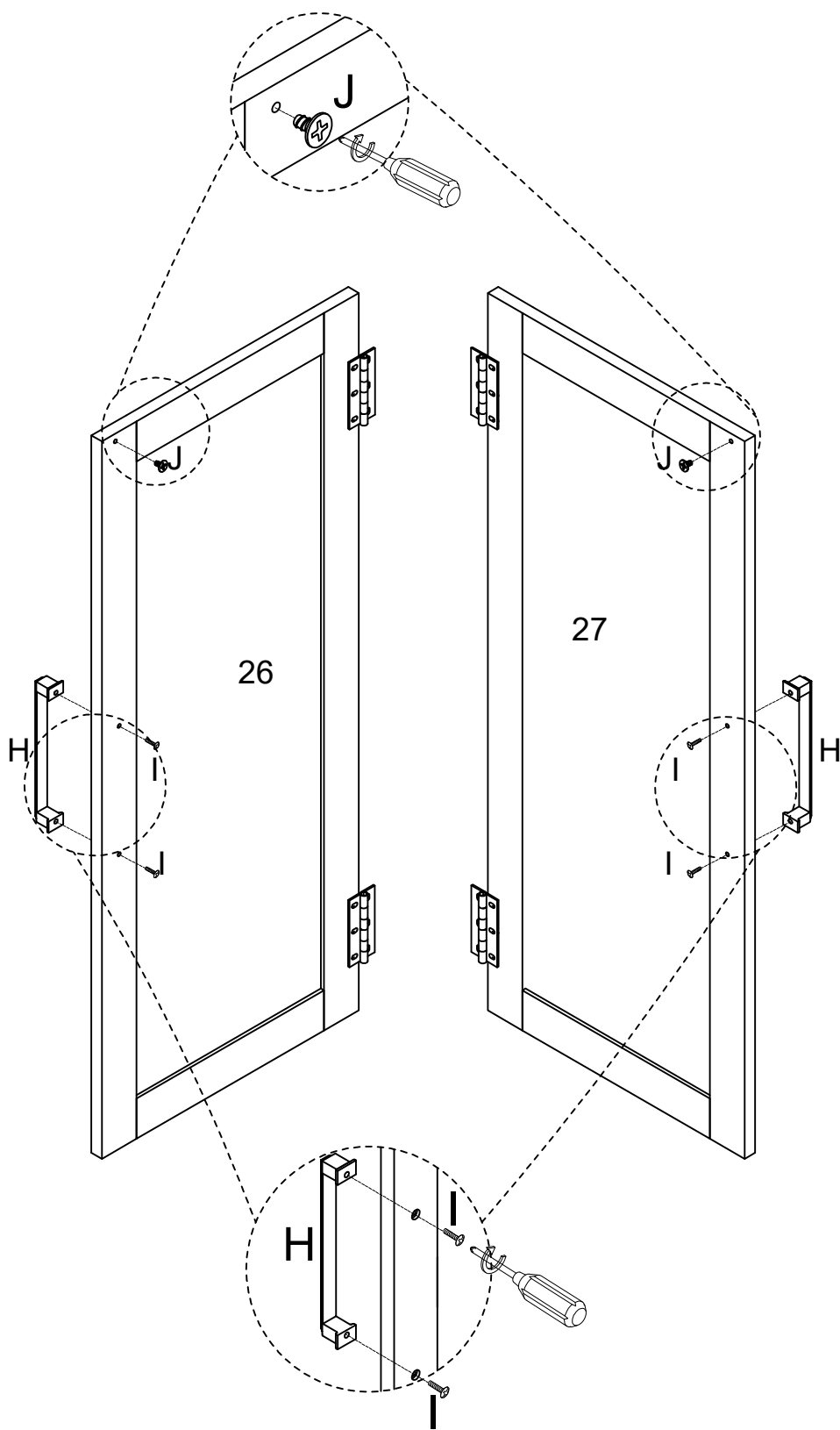

O	S
	
X12	X4

Step 32



H	I	J
		
X2	X4	X2

Step 33

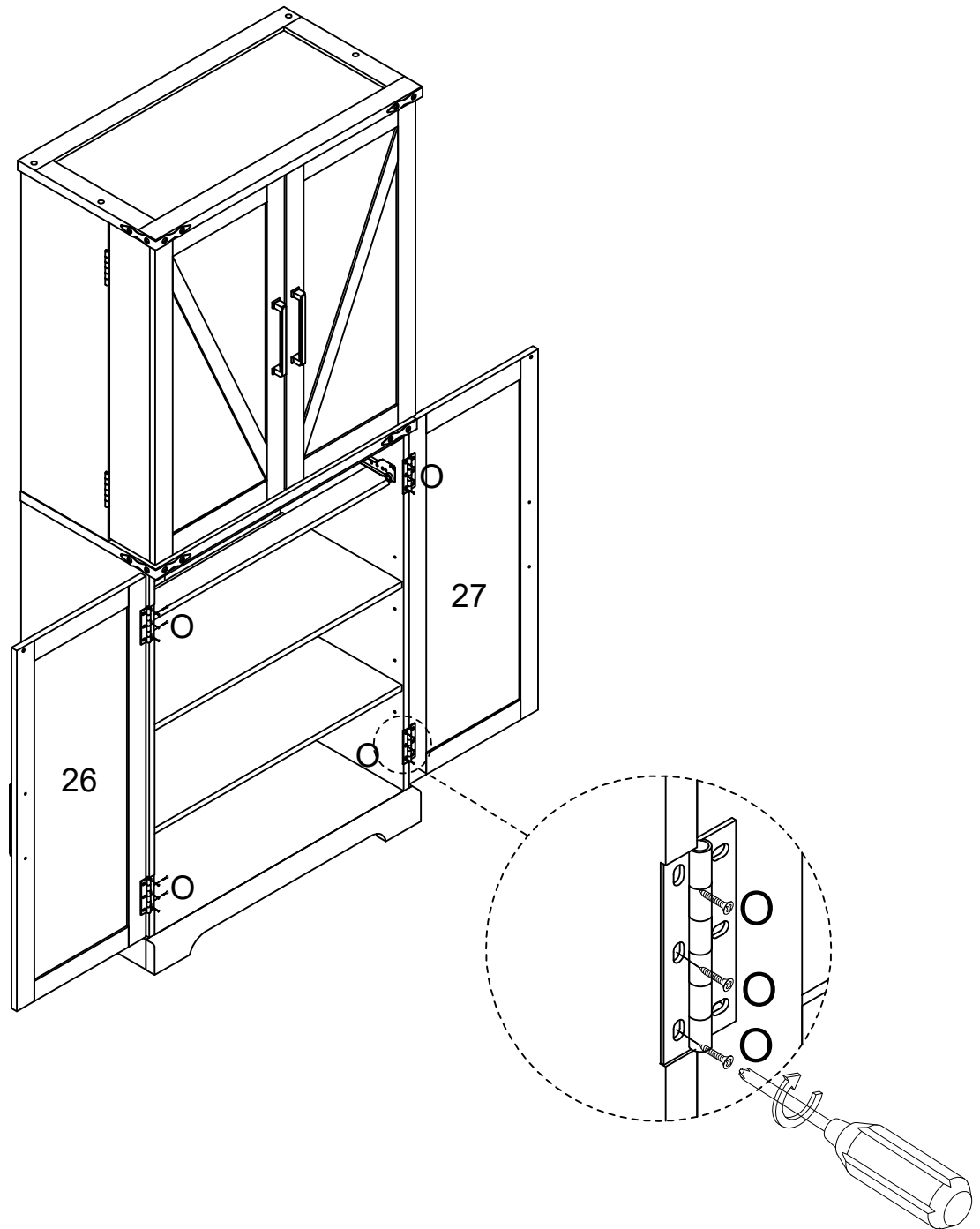

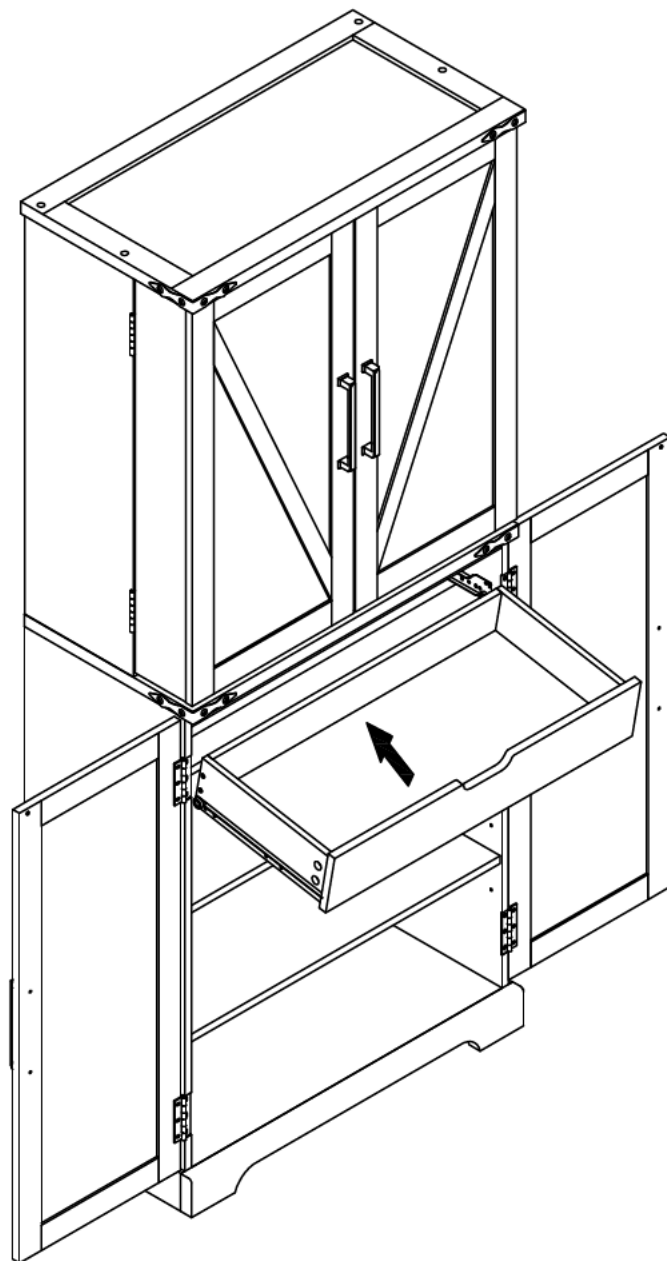

O

X12

Step 34

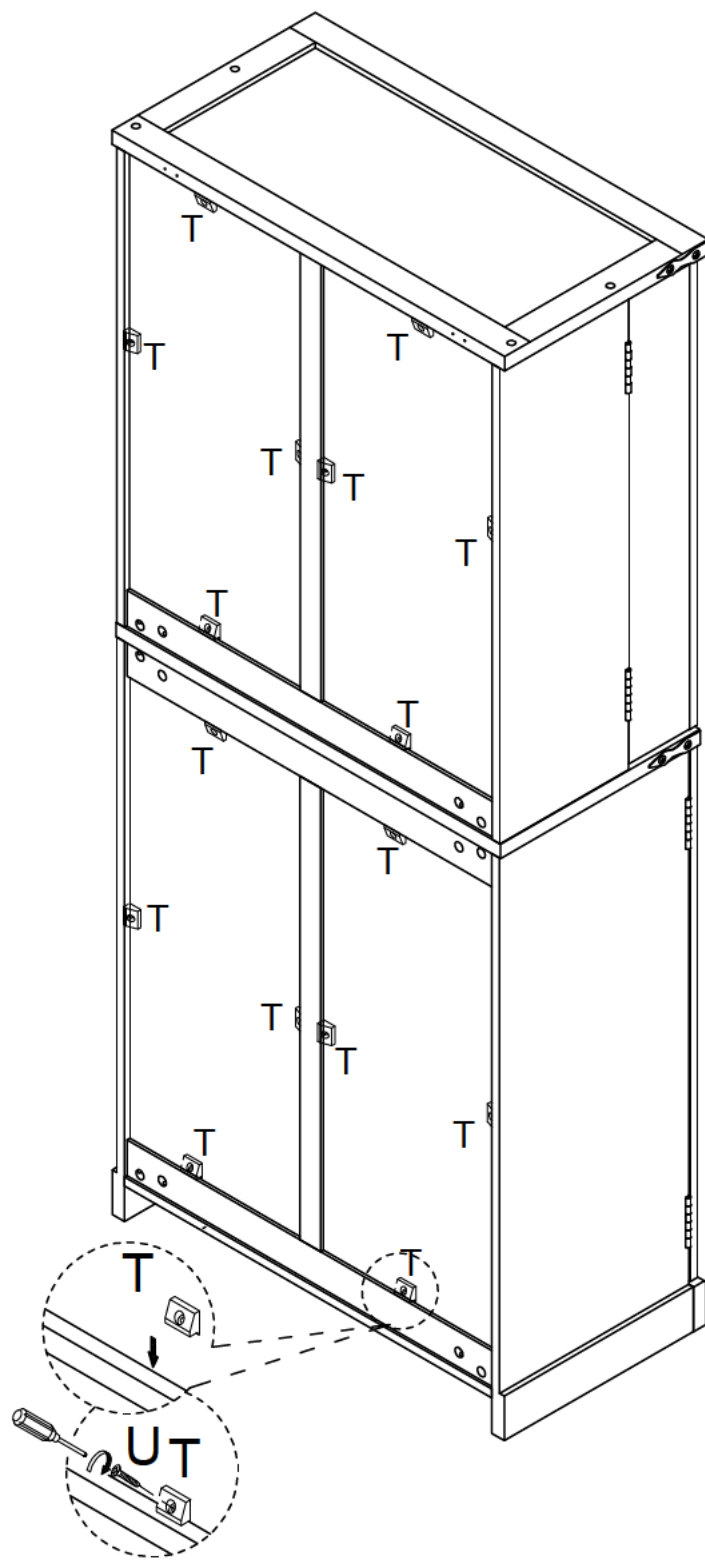



Step 35

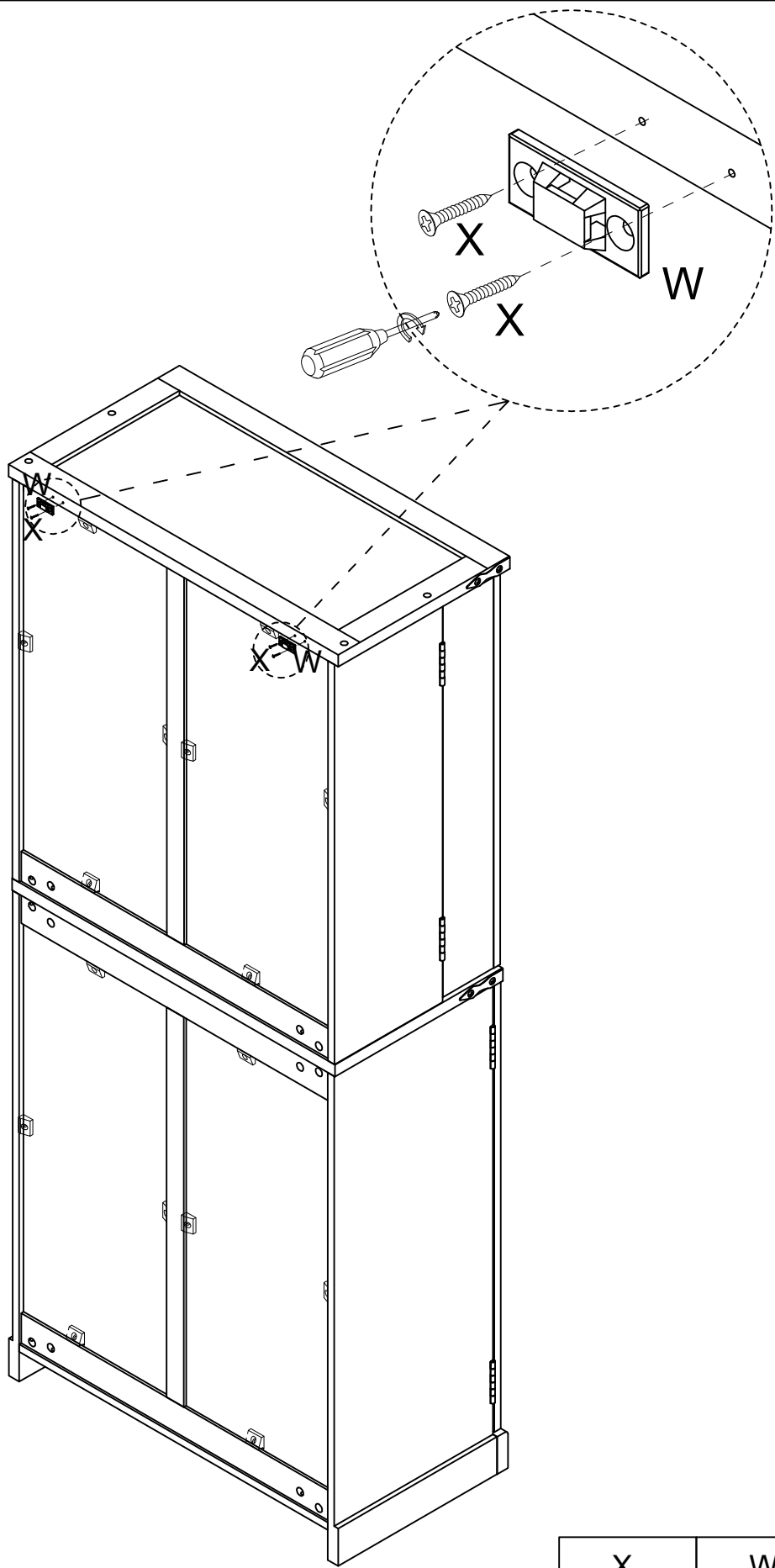

U	T
	
X16	X16

Step 36



X	W
	
X4	X2

Step 37

Make Four holes 45MM deep

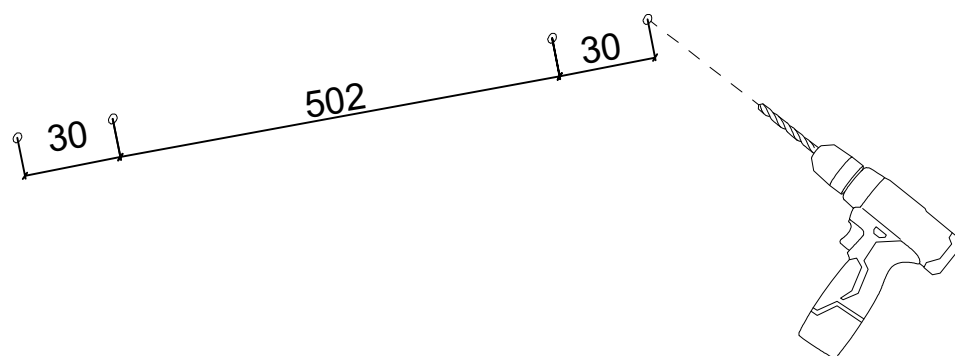

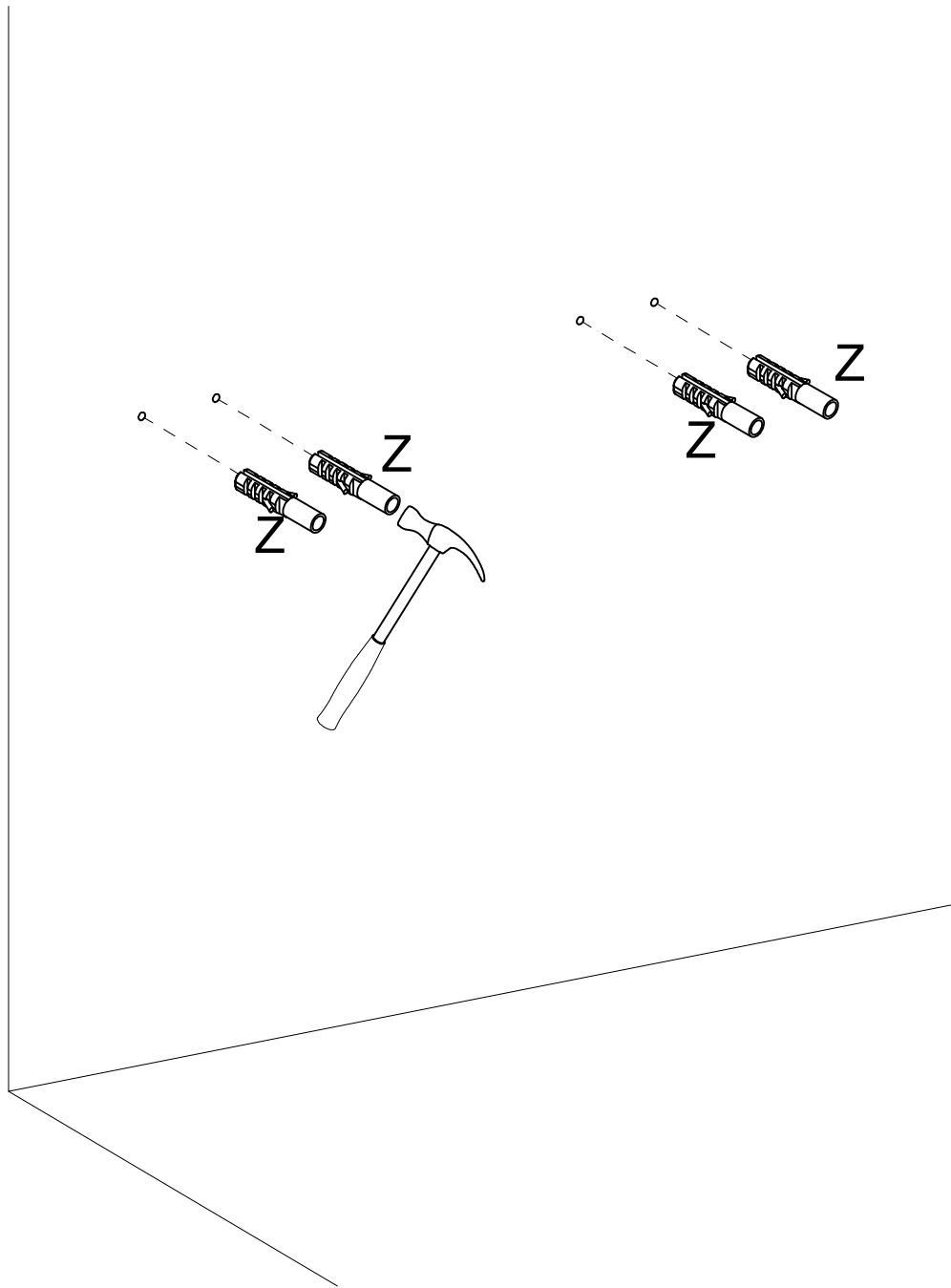

Step 38

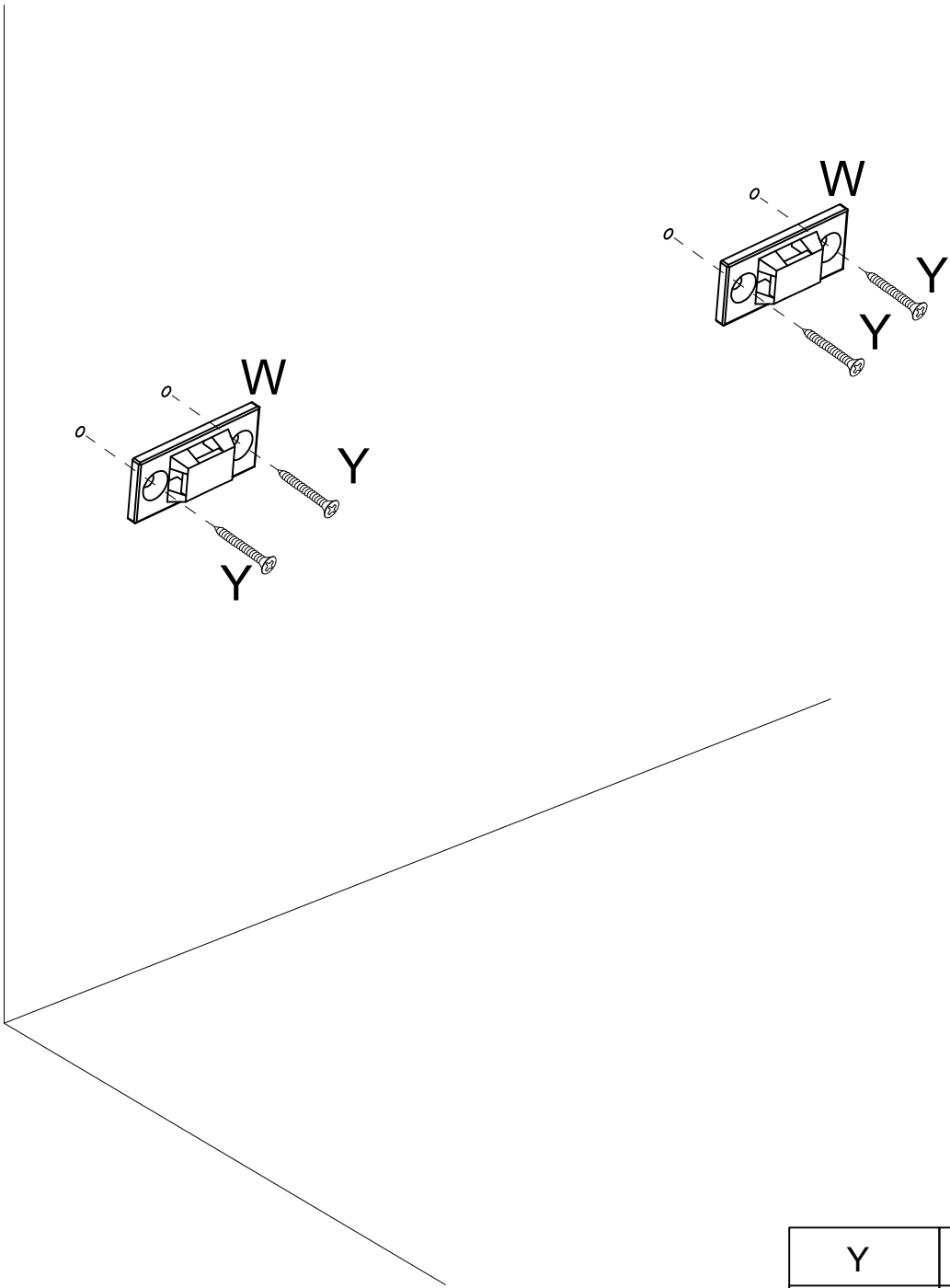

Z

X4

Step 39

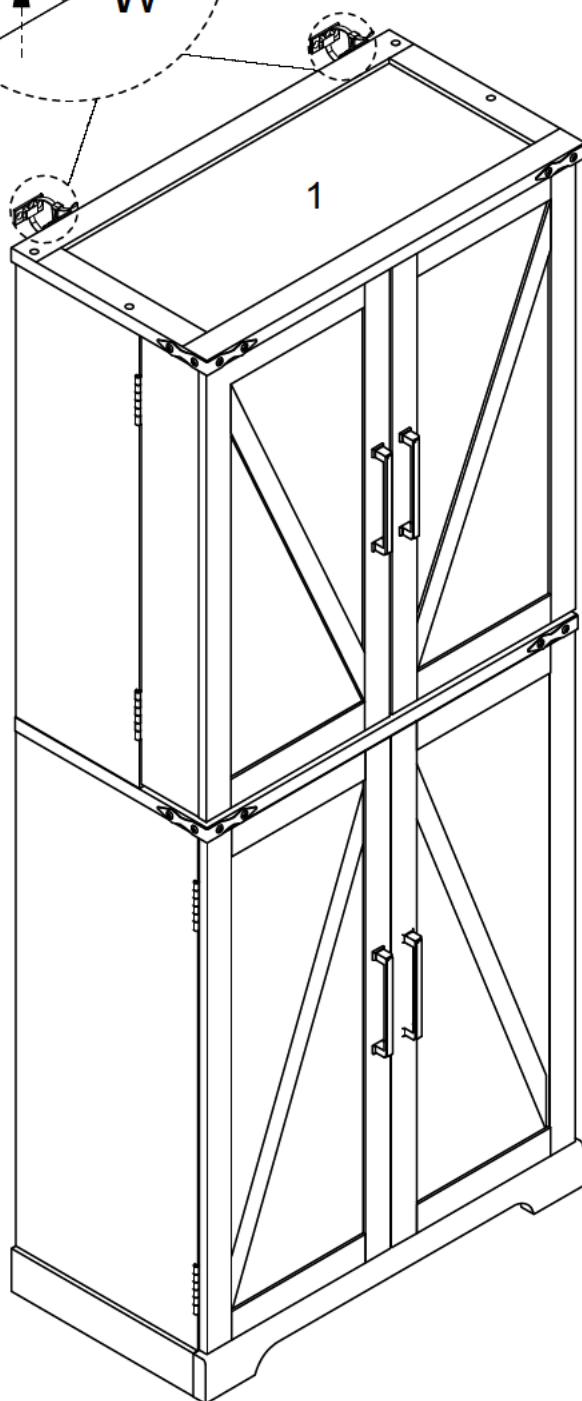
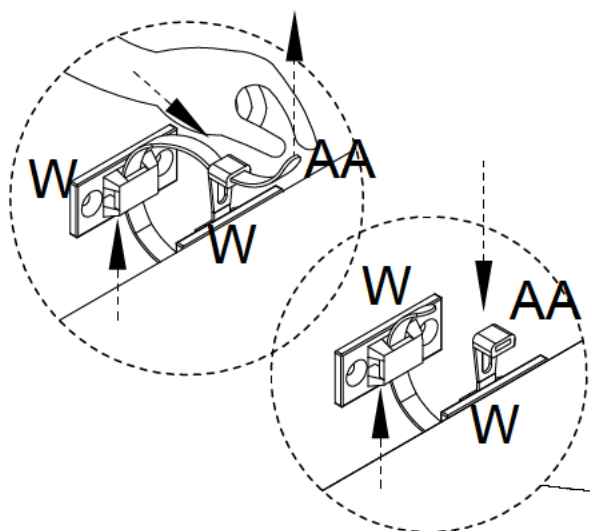

Y	W
	
X4	X2

Step 40



AA
X2

Step 41

