

SCHONBEK  
*Signature*<sup>TM</sup>

TEMPEST  
S5612- \_\_\_\_ / \_\_\_\_ R

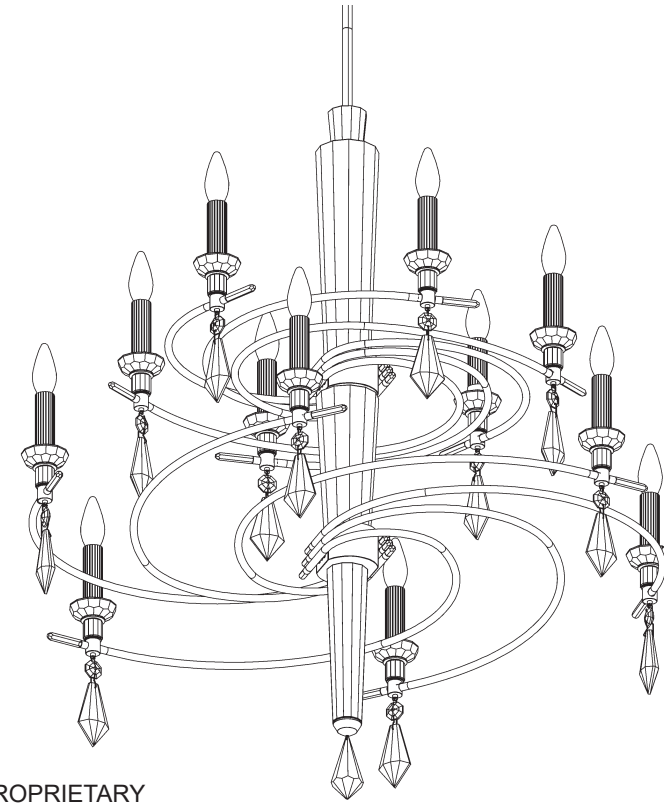

**T**HIS DESIGN IS THE PROPRIETARY  
TRADE DRESS/TRADEMARK OF  
W SCHONBEK LLC.

SCHONBEK  
*Signature*<sup>TM</sup>

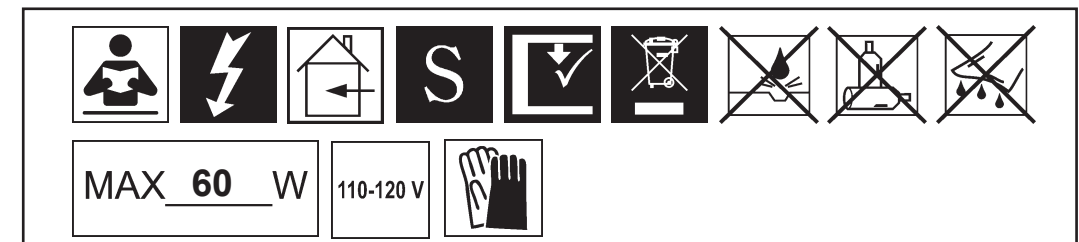

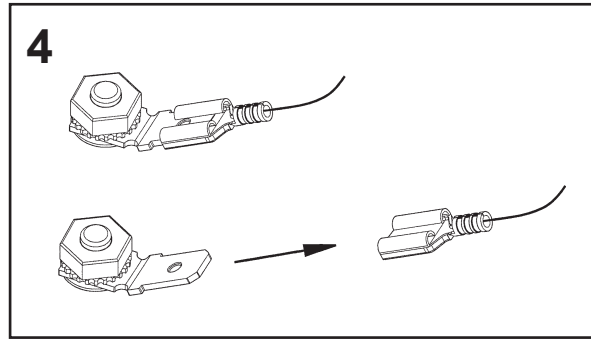

4

**NOTE:**  
 LOOSEN 1 SCREW, ON EACH SIDE OF MOUNTING WASHER, AND REMOVE THE OTHER (SET ASIDE)

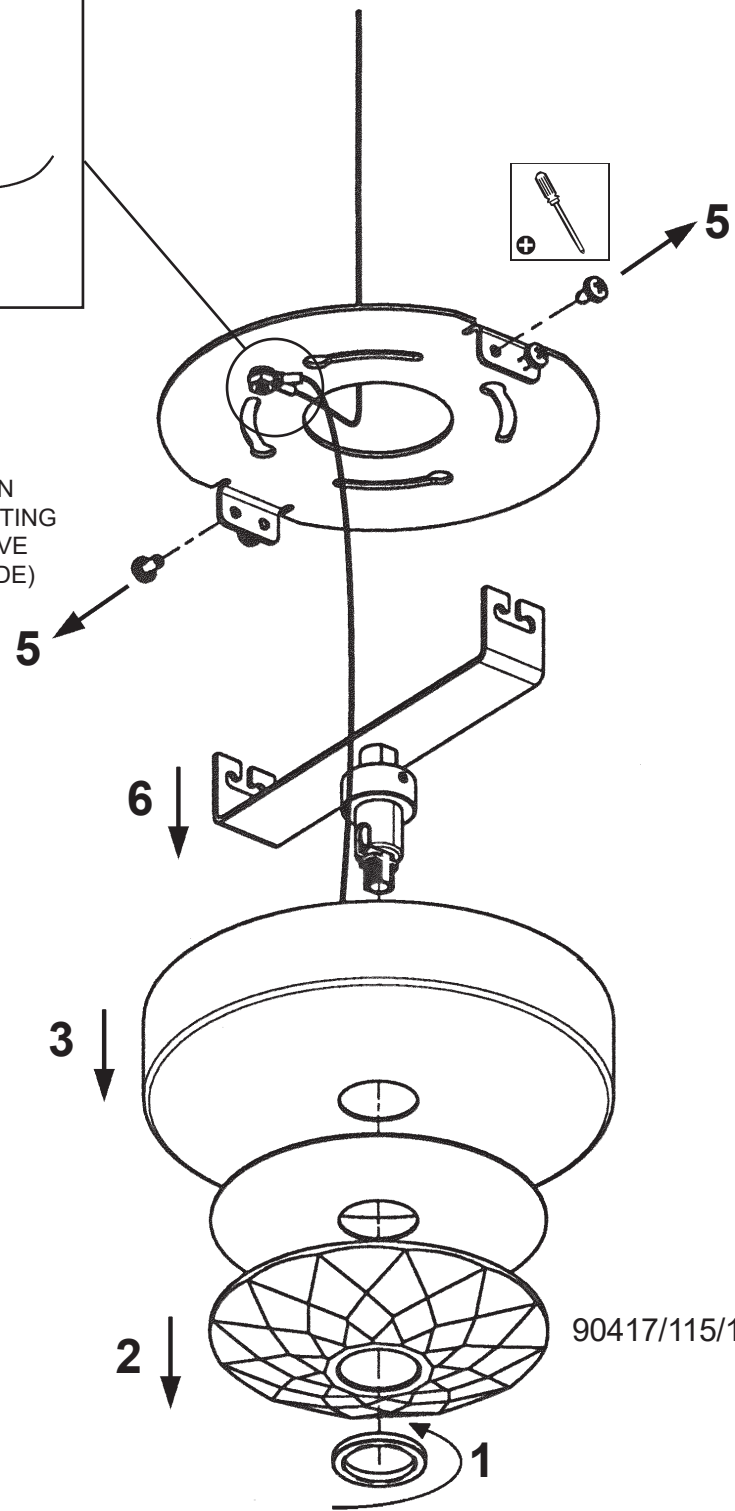

You will need 12 - B10  
 25 Watts Recommended  
 60 Watts Max

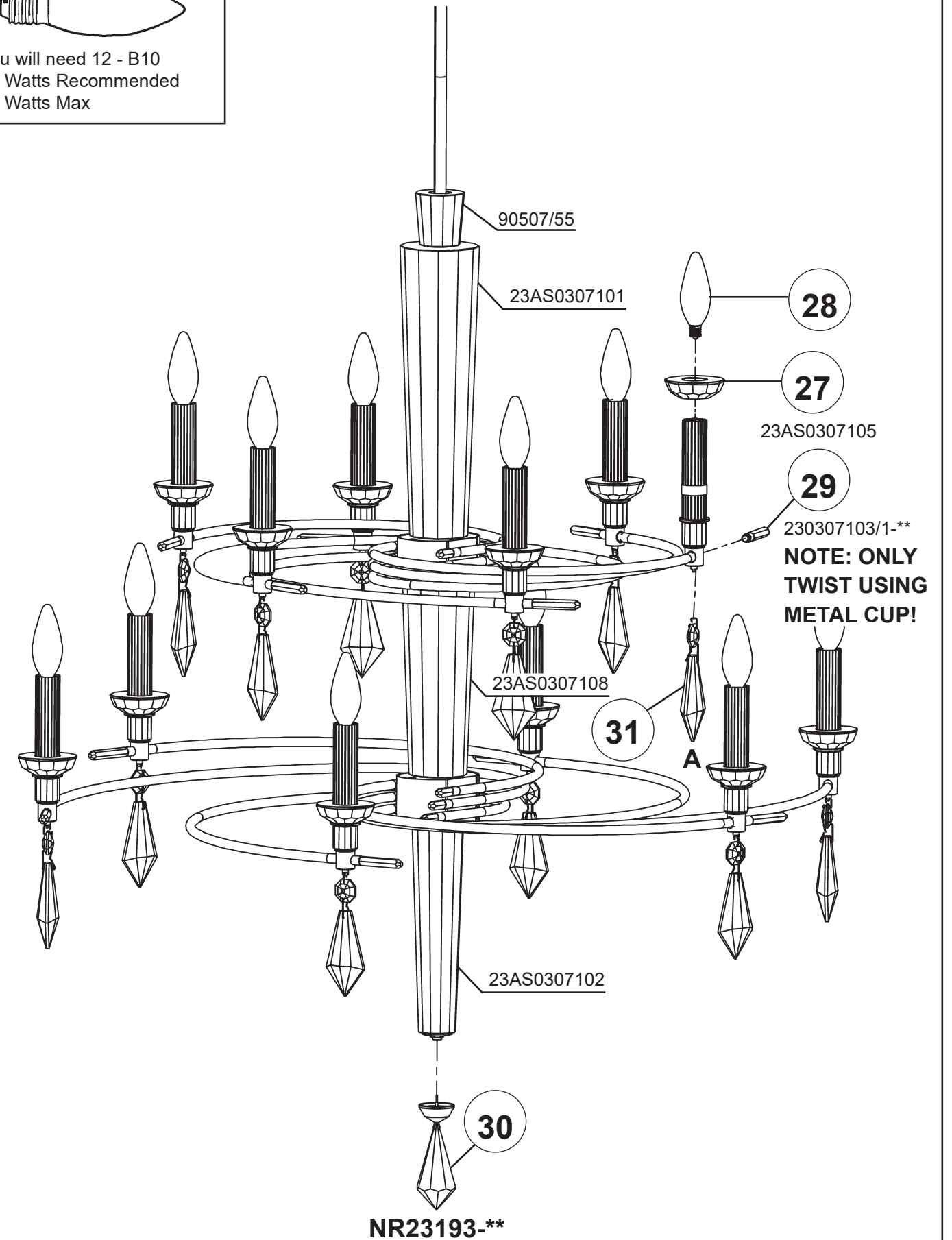

NR23193-\*\*

