

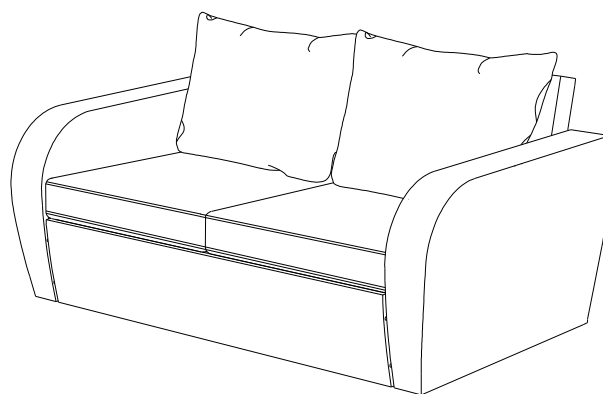

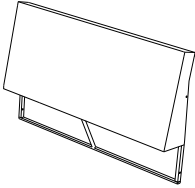

Outdoor Wicker Loveseat

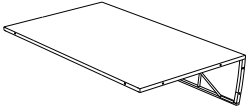

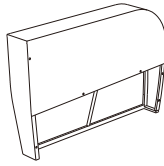
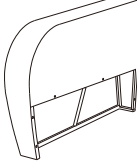
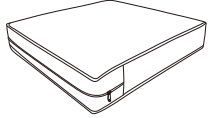
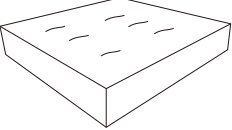
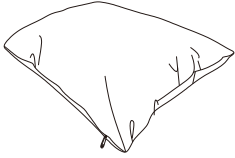
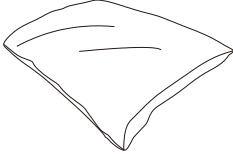

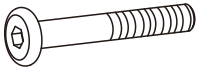
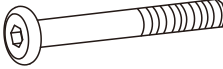
PART LIST

				
<p>Back Panel 1 PC</p>	<p>Seat Panel 1 PC</p>	<p>Right Arm Panel 1 PC</p>	<p>Left Arm Panel 1 PC</p>	<p>Cover of Seat Cushion * 2 PCS</p>
			<p>*Please note cushion covers will ship separately.</p>	
<p>Core of Seat Cushion 2 PCS</p>	<p>Cover of Back Cushion * 2 PCS</p>	<p>Core of Back Cushion 2 PCS</p>		

HARDWARE LIST

 <p>M6*55mm</p>	 <p>M6*65mm</p>	 <p>M6mm</p>	 <p>M6mm</p>	 <p>M6mm</p>
<p>Short Bolt 8 PCS</p>	<p>Long Bolt 6 PCS</p>	<p>Hex Nut 14 PCS</p>	<p>Flat Washer 28 PCS</p>	<p>Wrench 1 PC</p>
 <p>M6mm</p>				
<p>Allen Wrench 1 PC</p>				

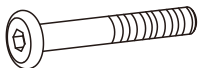
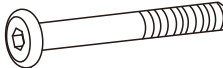
EXTRA HARDWARE LIST

 <p>M6*55mm</p>	 <p>M6*65mm</p>	 <p>M6mm</p>	 <p>M6mm</p>
<p>Short Bolt 1 PC</p>	<p>Long Bolt 1 PC</p>	<p>Hex Nut 1 PC</p>	<p>Flat Washer 1 PC</p>

Step 1. Lay left arm panel (part D) down on a soft flat surface, such as carpet, as shown below. Attach back panel (part A) to left arm panel (part D) using short bolts (part #1), flat washers (part #4), hex nuts (part #3), wrench (part #5) and allen wrench (part #6).

NOTE: Please do not fully tighten bolts until unit is fully assembled.

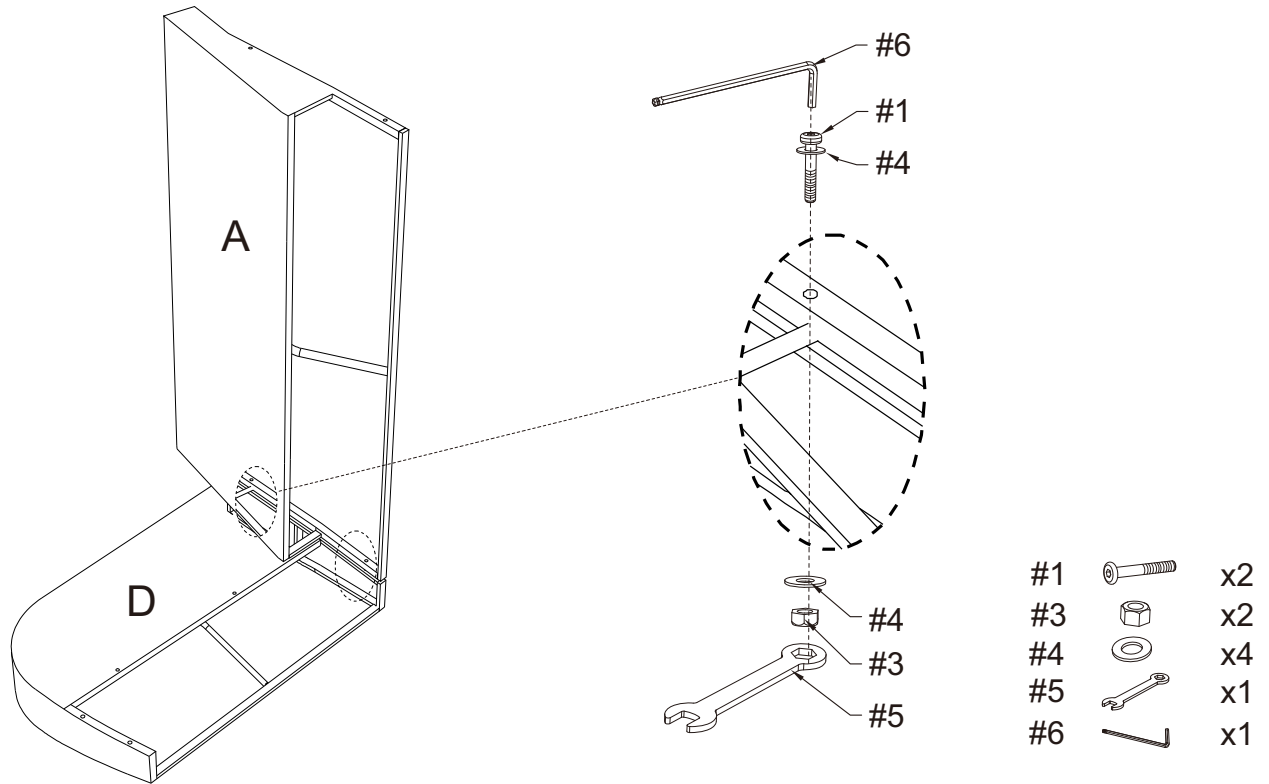

Step 2. Attach seat panel (part B) to back panel (part A) and left arm panel (part D) using short bolts (part #1), long bolts (part #2), flat washers (part #4), hex nuts (part #3), wrench (part #5) and allen wrench (part #6).

NOTE: Please do not fully tighten bolts until unit is fully assembled.

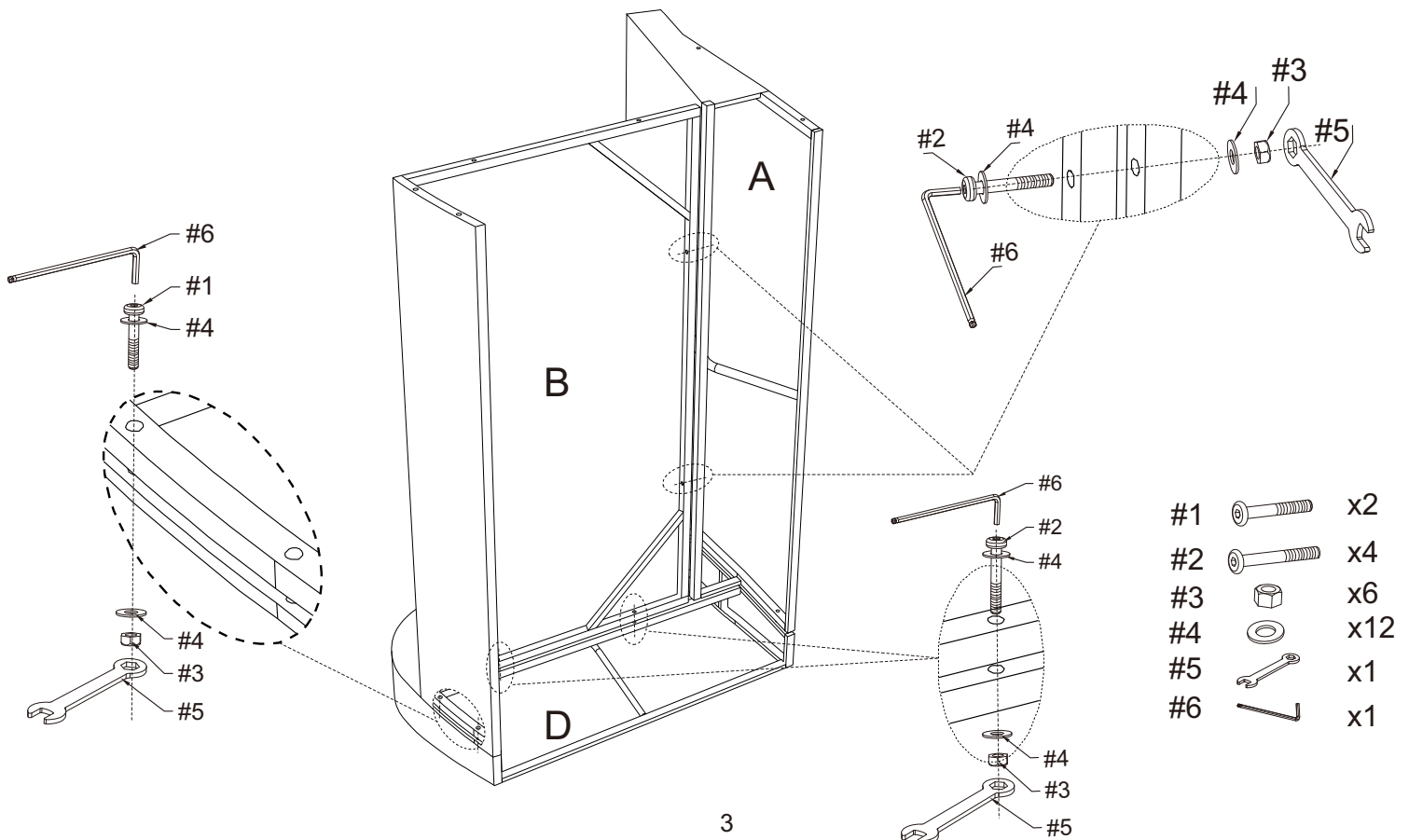

Step 3. Attach right arm panel (part C) to seat panel (part B) and back panel (part A) using short bolts (part #1), long bolts (part #2), flat washers (part #4), hex nuts (part #3), wrench (part #5) and allen wrench (part #6).

NOTE: Please fully tighten all bolts at this time.

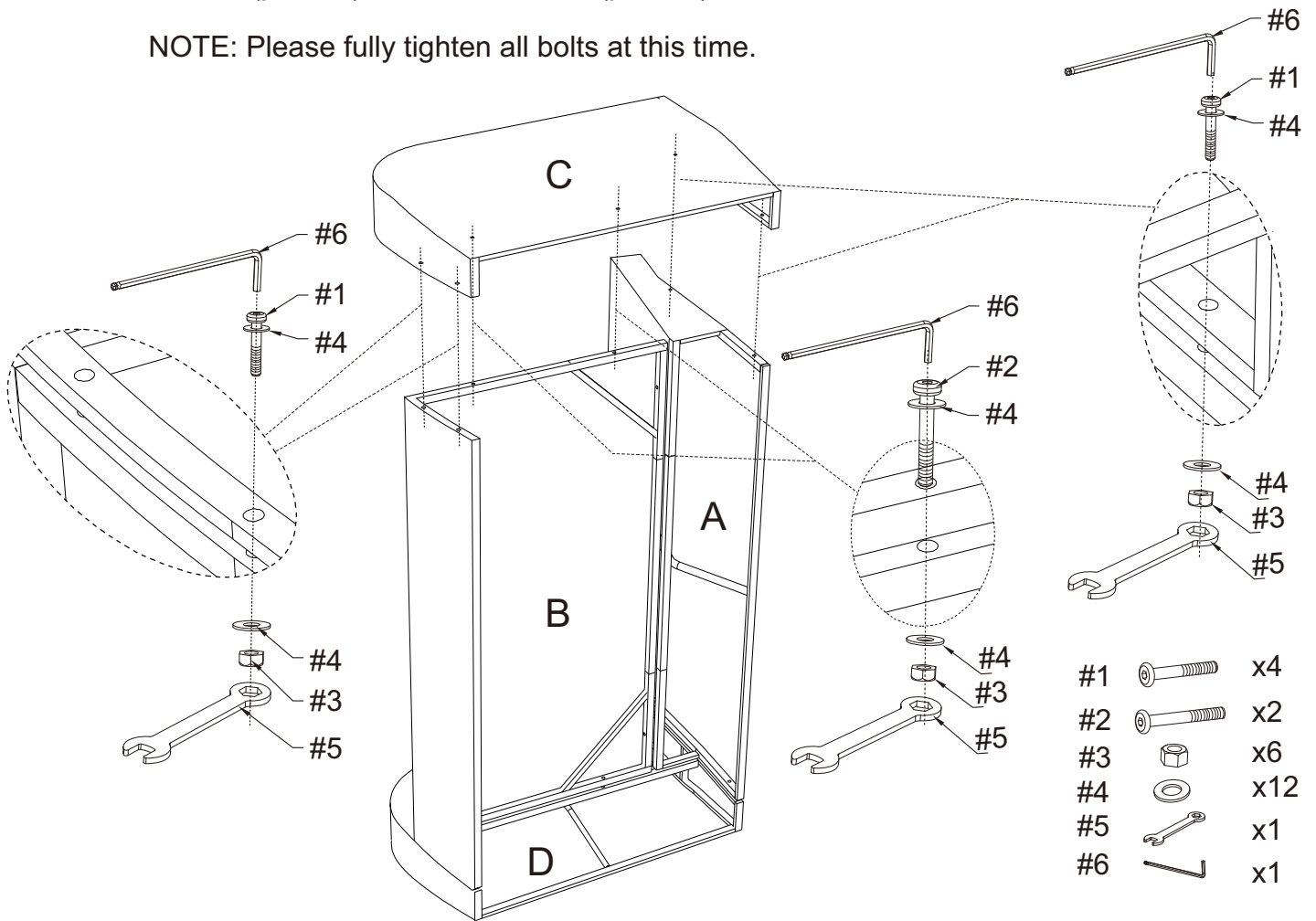

Step 4. Insert core of seat cushion (part F) into cover of seat cushion (part E). Insert core of back cushion (part H) into cover of back cushion (part G).

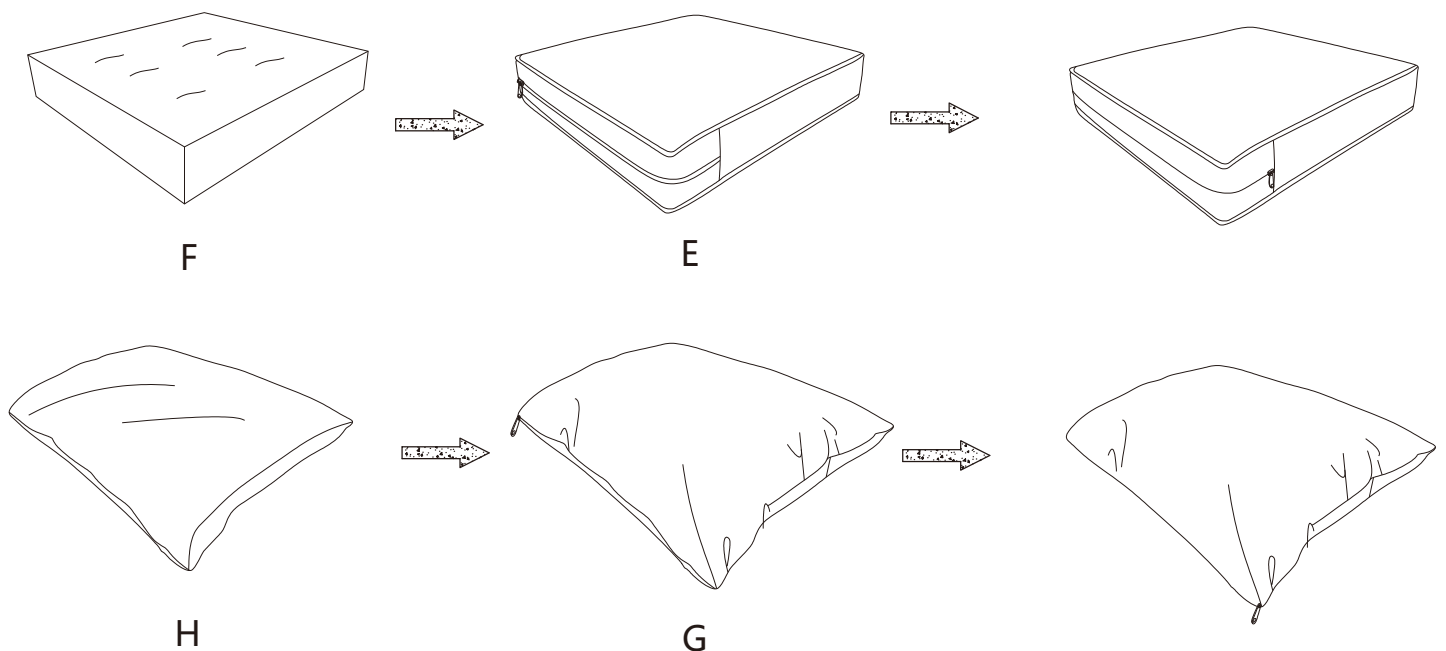

Step 5. Carefully turn the assembled loveseat upright and add cushions as shown below.

