

# ASSEMBLY INSTRUCTIONS

## BENCH Item# 2

ASSEMBLY REQUIREMENTS

2-Person  
Assembly

Assembly Time  
(Approximate)

30 MINUTES

### Thank you for purchasing our product!

Please refer and use this assembly instruction to assemble the product.  
Contact our customer service department in case there are any missing or damage parts or hardware. Replacement parts are normally shipped within 2 or 3 days.

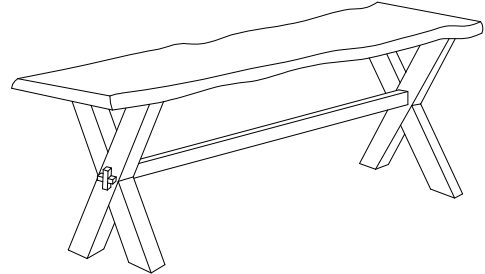

### ASSEMBLY PREPARATION

1. Remove all packaging materials, staples and packing straps from the carton.
2. Refer to Part List and Hardware List and ensure parts and hardware are complete before assembly.  
Contact customer service for missing parts.
3. Place all wooden parts on a clean, flat and soft surface (e.g. carpet or rug) to prevent parts from getting scratched.

### SAFETY PRECAUTION:

1. KEEP ALL HARDWARE PARTS OUT OF REACH OF CHILDREN.
2. DISPOSE PLASTIC PACKAGING MATERIAL IMMEDIATELY TO AVOID ANY RISK OF SUFFOCATION TO CHILDREN AND ANIMALS.

### TIPS FOR ASSEMBLY:

1. Allow ample room for assembly and in close proximity to where product will be placed.
2. Assemble the product on a surface that does not scratch or damage the exterior gloss and finish of the furniture.
3. Identify all of the parts, hardware and quantities required for each step.
4. During assembly, do not over-tighten any fittings as this may cause damage.
5. DO NOT USE POWER TOOLS TO ASSEMBLE THIS PRODUCT.
6. Always place the product on a flat, level surface.
7. Do not sit or stand on the partially assembled product; only use the product for which it is intended.

### CARE AND MAINTENANCE

- Use a slightly damp cloth to clean the product. Do not use bleach or abrasive cleaning material.
- Check all the fittings periodically and re-tighten as necessary. Do not use the product if any of the parts is damaged or broken.
- Never allow any kind of liquid to remain on your furniture. Absorption can cause wood to warp or delaminate.
- Do not place hot items (e.g. hot drinks) directly onto the wood surface.
- Do not drag and/or pull the furniture.

This product is for indoor and household use only - not for commercial use.





# ASSEMBLY INSTRUCTIONS

## BENCH Item#

### PART LIST (FOR 1 TABLE)

NO.	COMPONENT	QTY.
P1	BENCH SEAT	1 PC.
P2	BENCH LEG	2 PCS.
P3	MOUNTING PLATE	2 PCS.
P4	CROSS BAR	1 PC.
P5	STOPPER	2 PCS.

### HARDWARE LIST (FOR 1 NOS. OF TABLE)

NO.	DESCRIPTION	QTY.	EXTRA
H1	JCBC BOLT M6 x 40MM 	18 PCS.	1 PC.
H2	JCBC BOLT M6 x 60MM 	2 PCS.	1 PC.
H3	SPRING WASHER M6 x 13MM 	18 PCS.	1 PC.
H4	WOOD DOWEL M8 x 35MM 	4 PCS.	1 PC.
H5	ALLEN KEY M4 x 65MM 	1 PC.	

### STEP 1

- a) With the assistance of another person, place the Bench Seat (P1) bottom-side up on a material that does not scratch or damage the surface of the top side.
- b) Remove the pre-assembled Mounting Plate (P3) from the Bench Seat (P1) by unscrewing the wood screws.

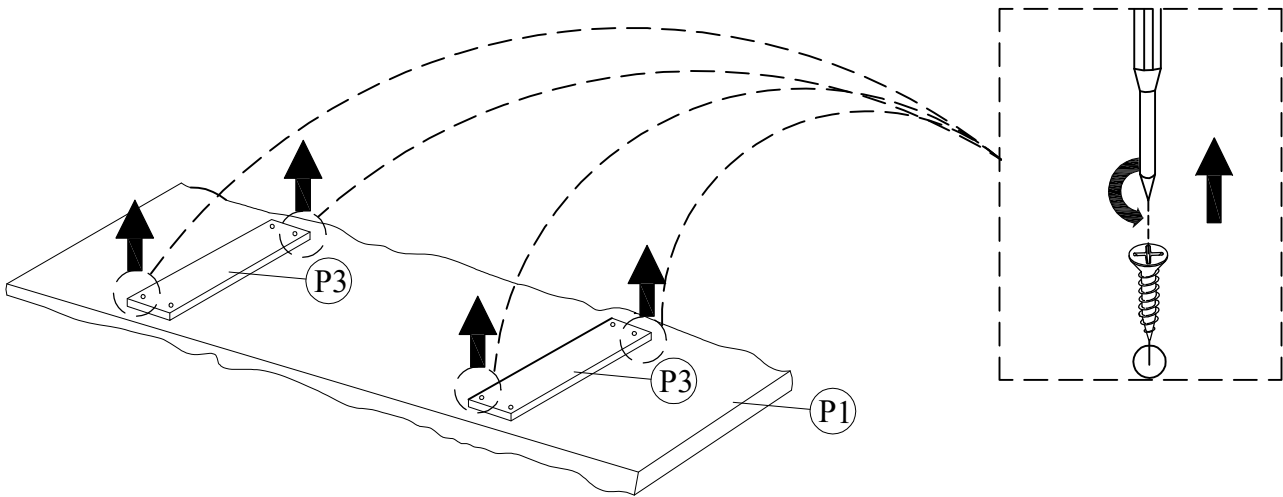

### STEP 2

Attach Mounting Plate (P3) to Bench Leg (P2) by inserting Bolt (H1) fitted with Spring Washer (H3) and using Allen Key (H5) to fasten. Do not tighten (H1) completely until all 4 bolts are in place.

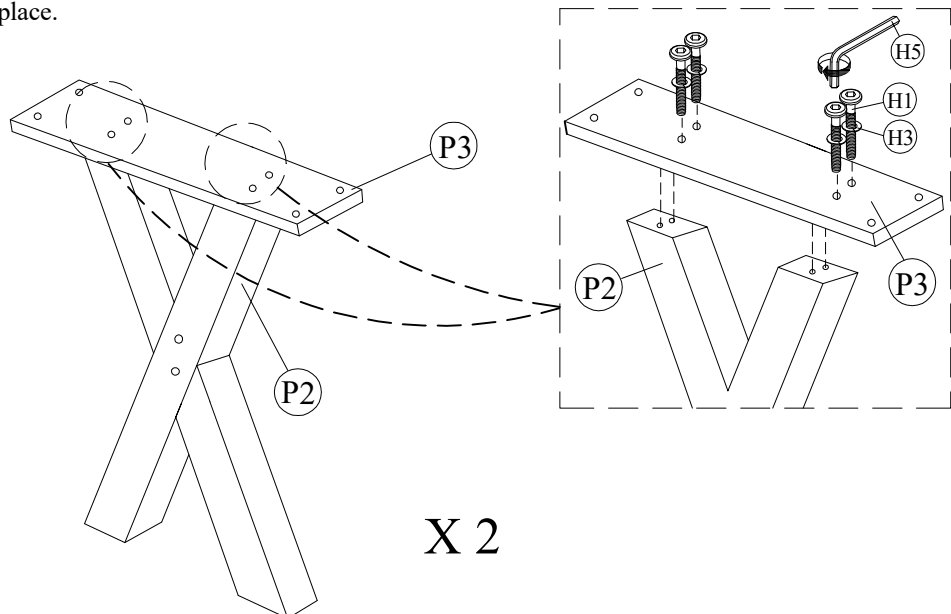

# ASSEMBLY INSTRUCTIONS BENCH

## Item# 2

### STEP 3

- Attach Cross Bar (P4) to Bench Leg (P2) using Wood Dowel (H4) as shown.
- Insert JCBC Bolt (H2) fitted with Spring Washer (H3) through the center bolt hole on Bench Leg (P2) into bolt hole on (P4). Use Allen Key (H5) to drive (H2) to fasten Bench Leg (P2) to Cross Bar (P4). Tighten (H2) completely.

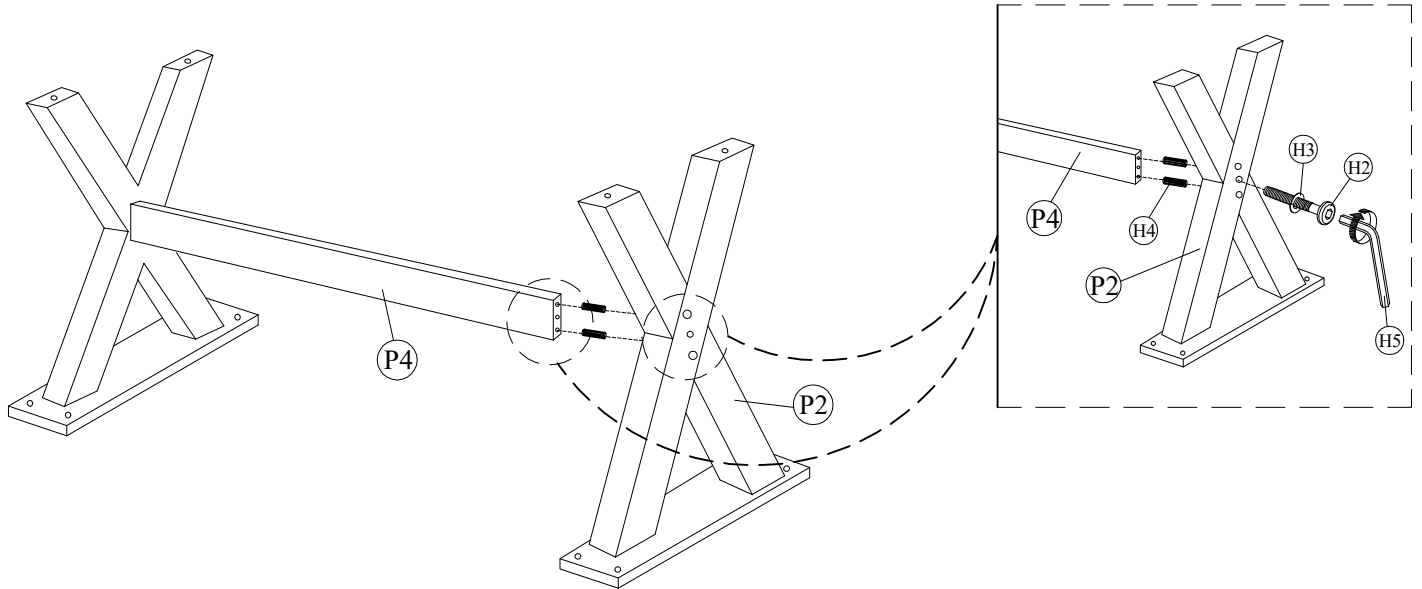

### STEP 4

- Position the assembled Bench Leg (P2) from Step 3 on the bottom of the Bench Seat (P1) and align the screw holes on (P3) to the screw hole on (P1).
- Insert JCBC Bolt (H1) fitted with Spring Washer (H3) into each hole. Use Allen Key (H5) to drive (H1) to fasten Mounting Plate (P3) to Bench Top (P1). Do not tighten (H1) completely until all bolts are in place - do not over-tighten.
- Attach the Stopper (P5) to the holes on Bench Leg (P2).
- With assistance, set the bench right-side up. The assembly of the bench is complete.

