

USER'S MANUAL

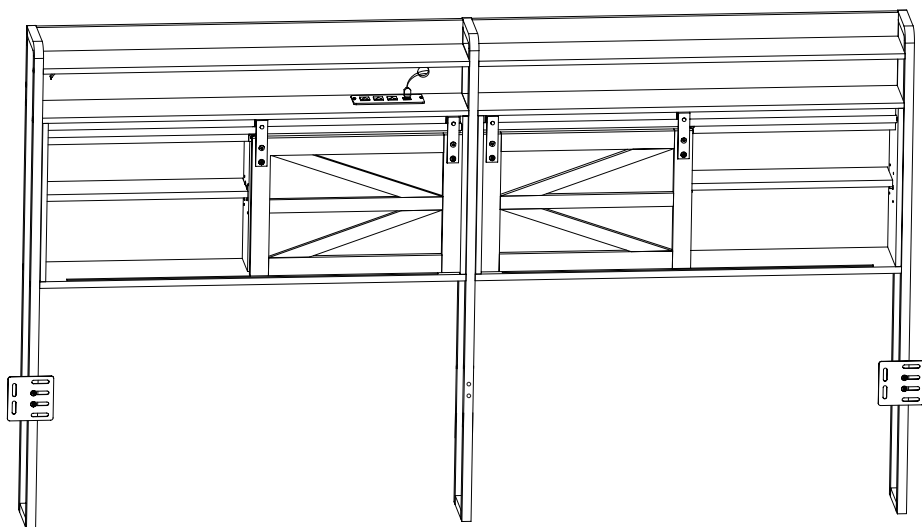

PARTS LIST

A x 1

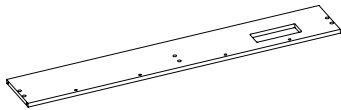

B x 1

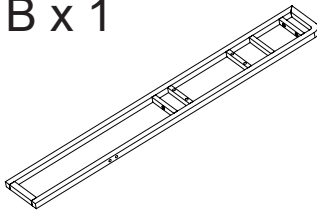

C x 1

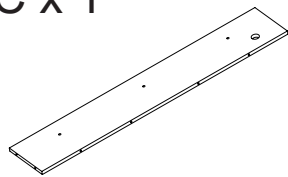

D x 1

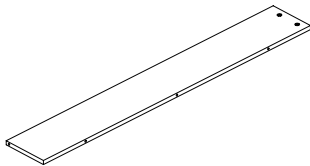

E x 1

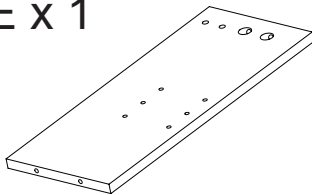

F x 1

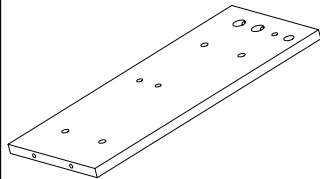

G x 2

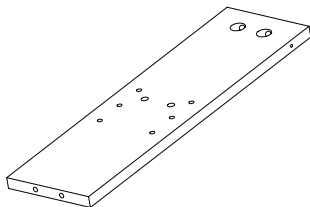

H x 1

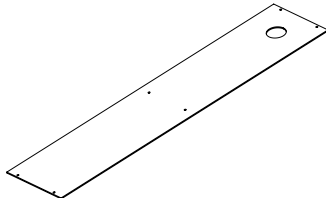

I x 1

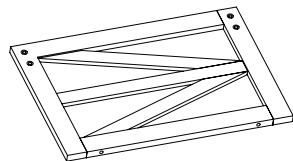

J x 1

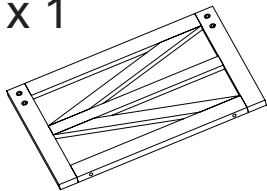

K x 3

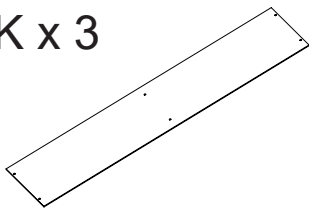

L x 2

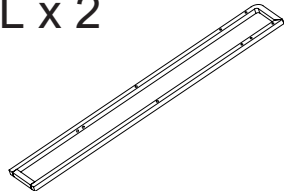

M x 2

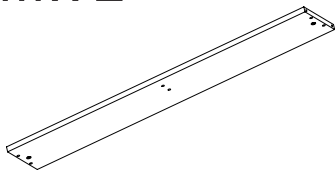

N x 2

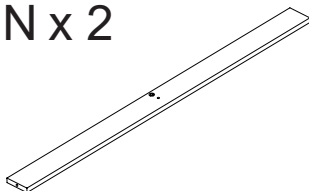

O x 1

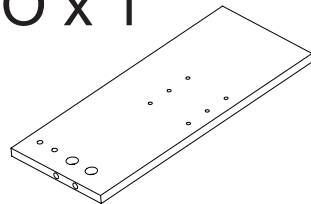

P x 1

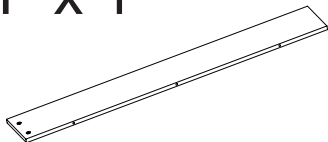

Q x 1

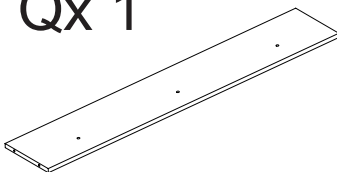

R x 1

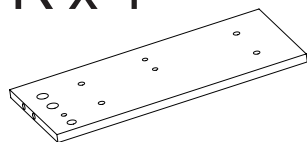

PARTS LIST

S x 1

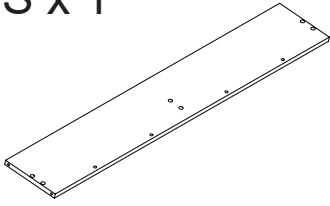

T x 2

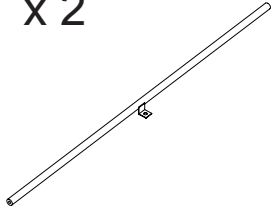

U x 2

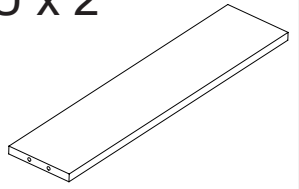

V x 2

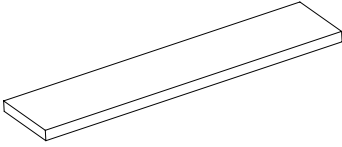

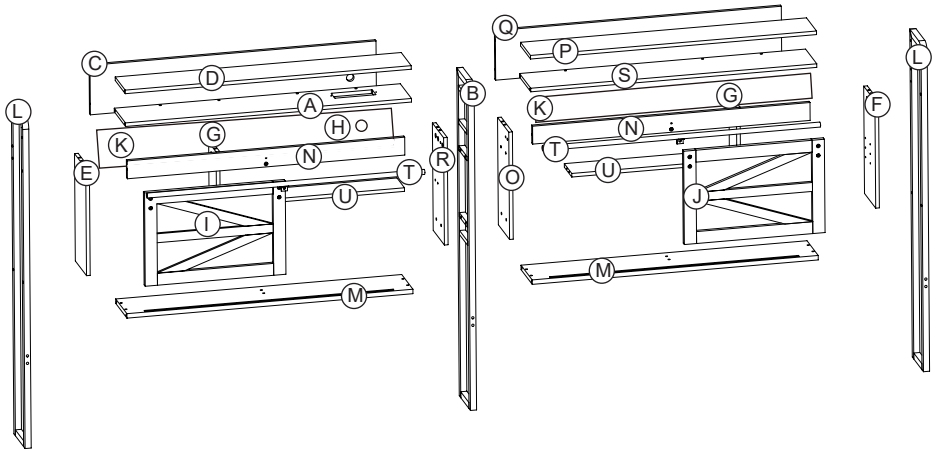

PARTS LIST

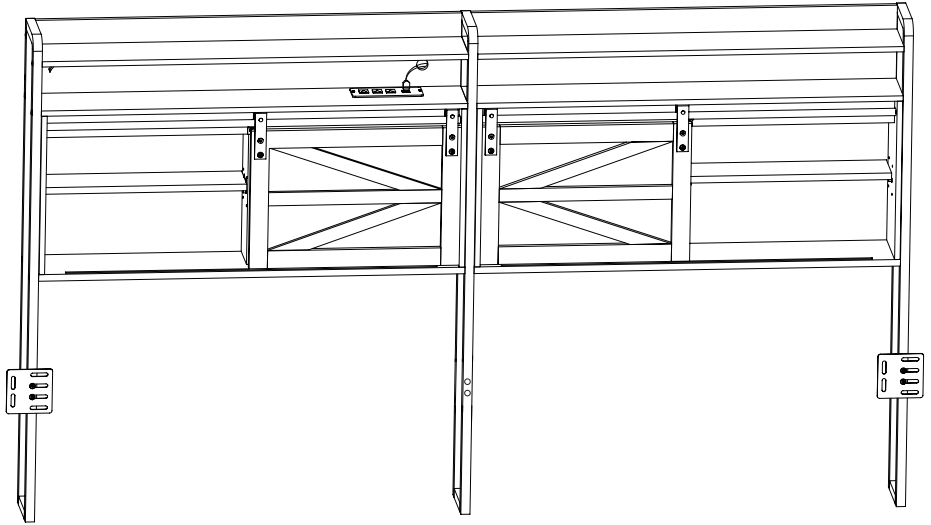

Hardware

<p>① x 12</p>	<p>② x 12</p>	<p>③ x 2</p>	<p>④ x 19</p>	<p>⑤ x 16</p>
<p>⑥ x 24</p>	<p>⑦ x 52</p>	<p>⑧ x 8</p>	<p>⑨ x 4</p>	<p>⑩ x 1</p>
<p>⑪ x 4</p>	<p>⑫ x 2</p>	<p>⑬ x 8</p>	<p>⑭ x 2</p>	<p>⑮ x 4</p>
<p>⑯ x 3</p>	<p>LED</p> <p>Clip x 7</p>	<p>TOOLS</p>		

Step 1

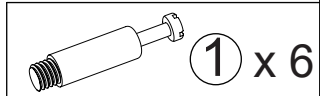
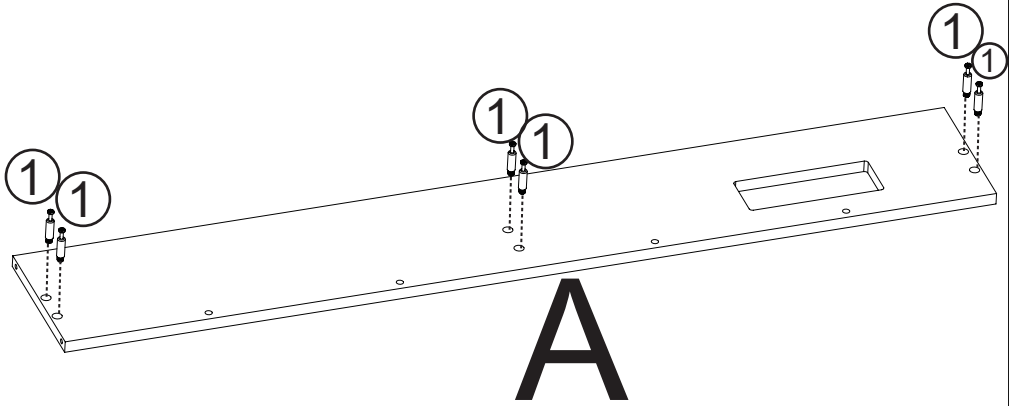
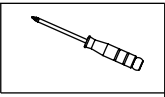

Step 2

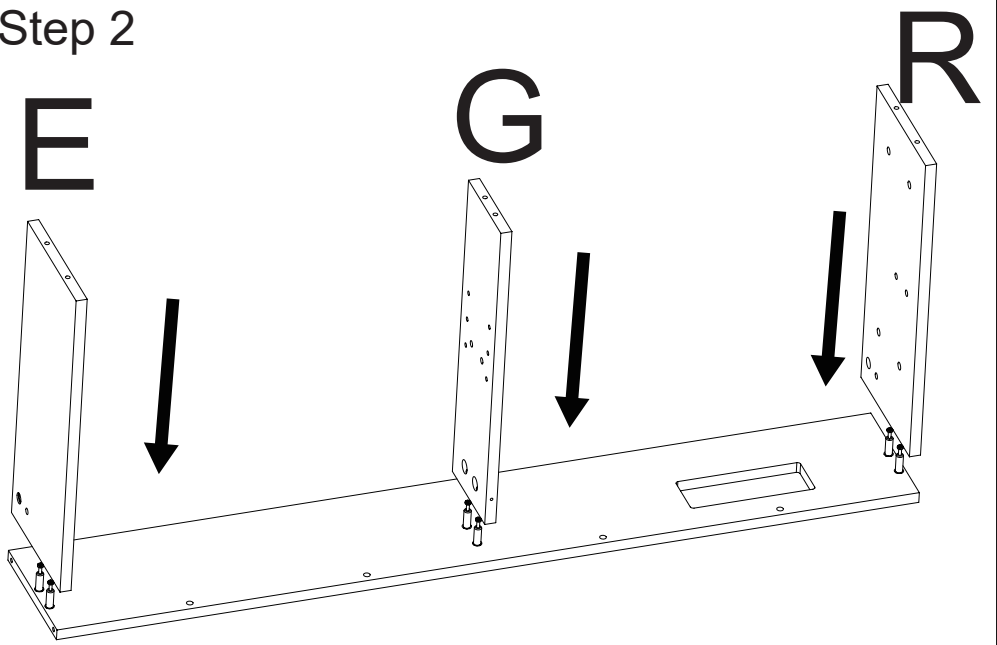

Step 3

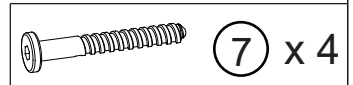
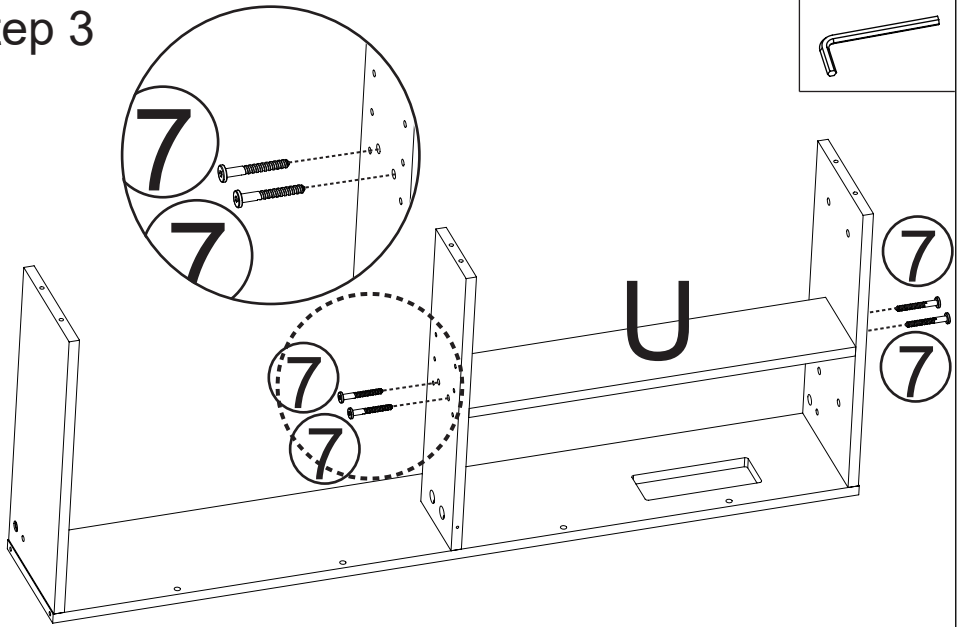

Step 4

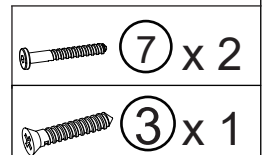
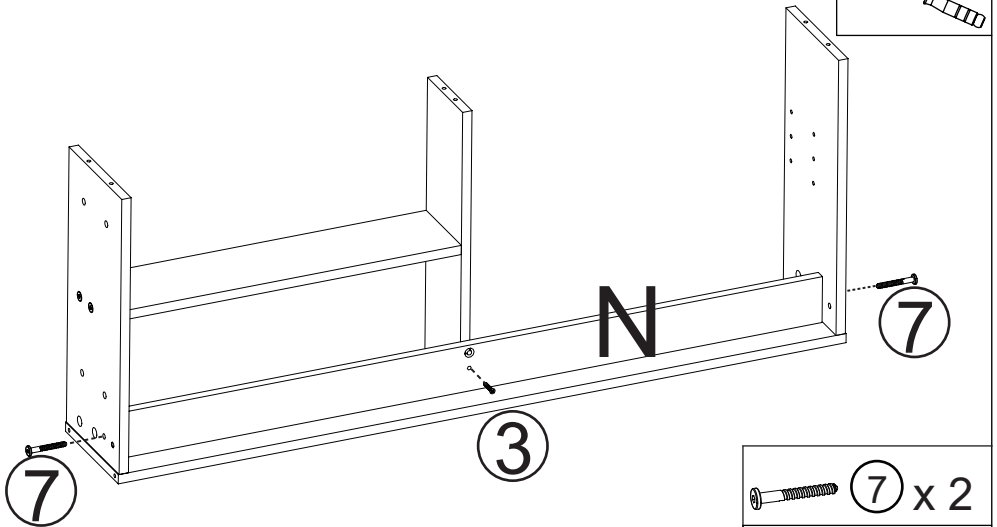

Step 5

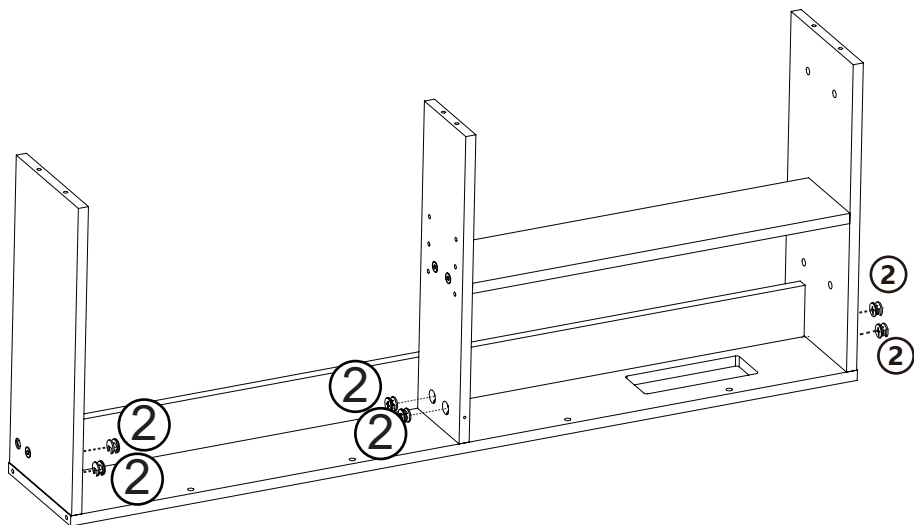
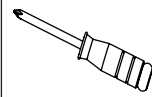

② x 6

Step 6

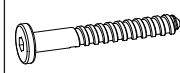
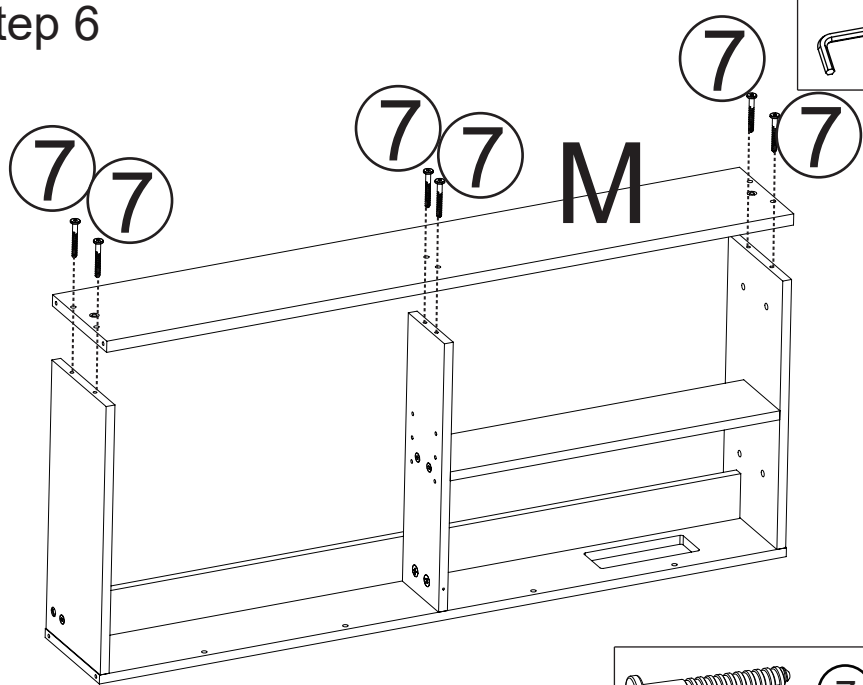
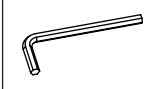

⑦ x 6

Step 7

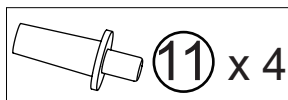
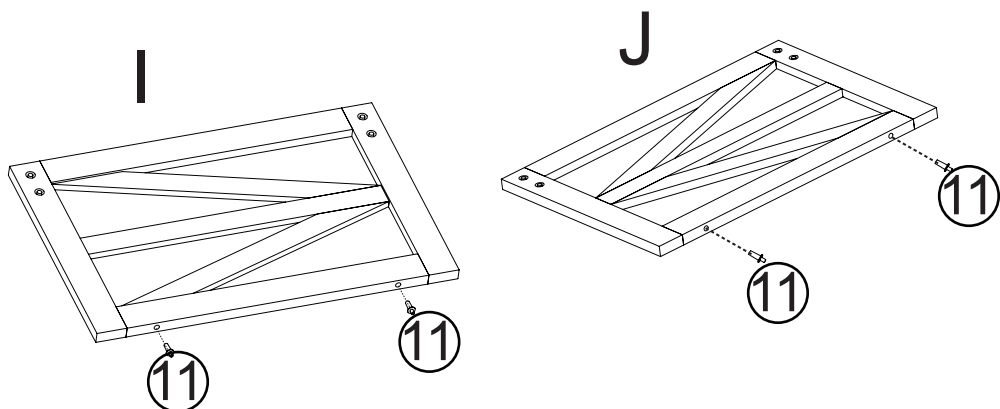

Step 8

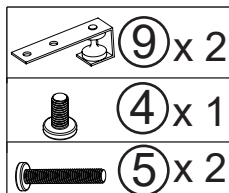
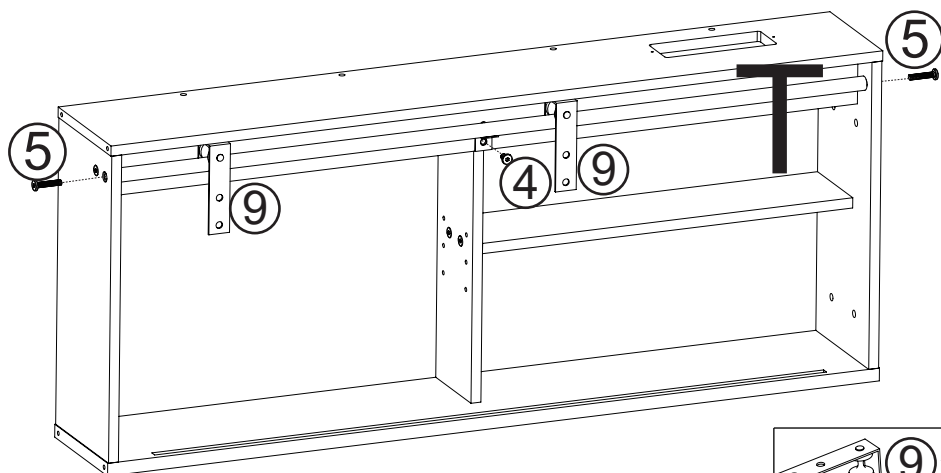
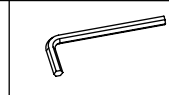

Step 9

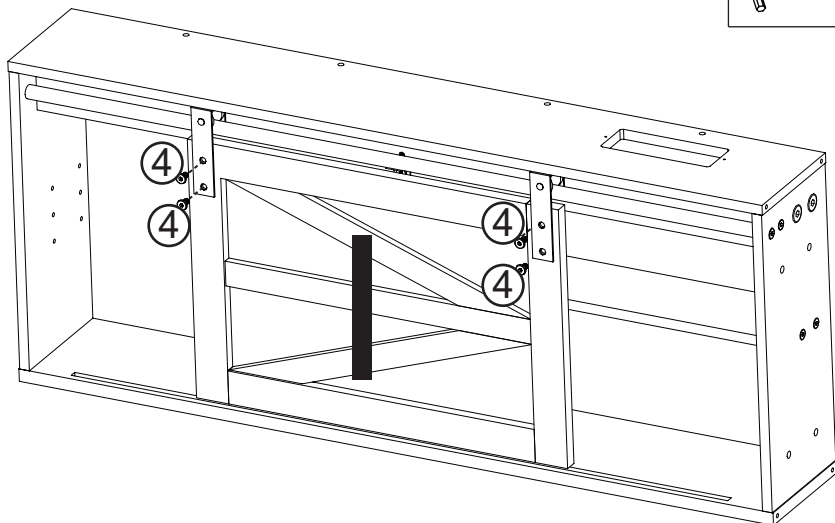

4 x 4

Step 10

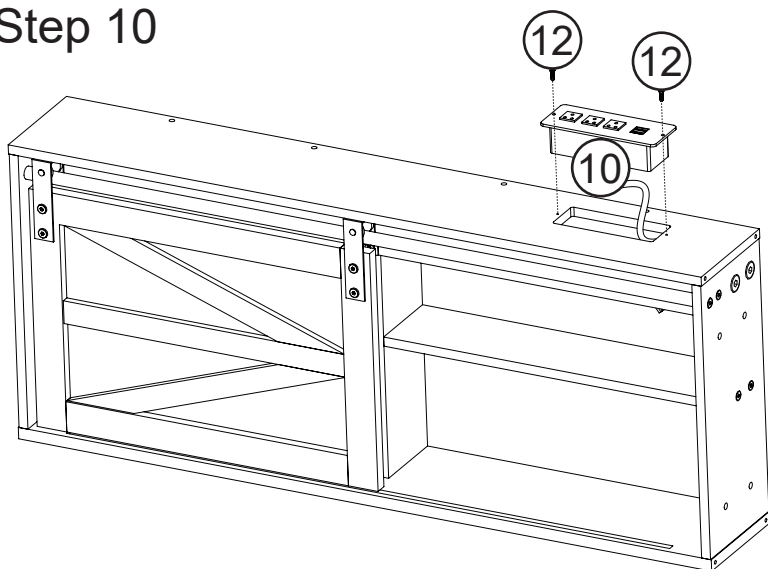
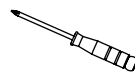

12 x 2

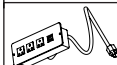

10 x 1

Step 11

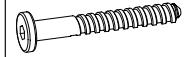
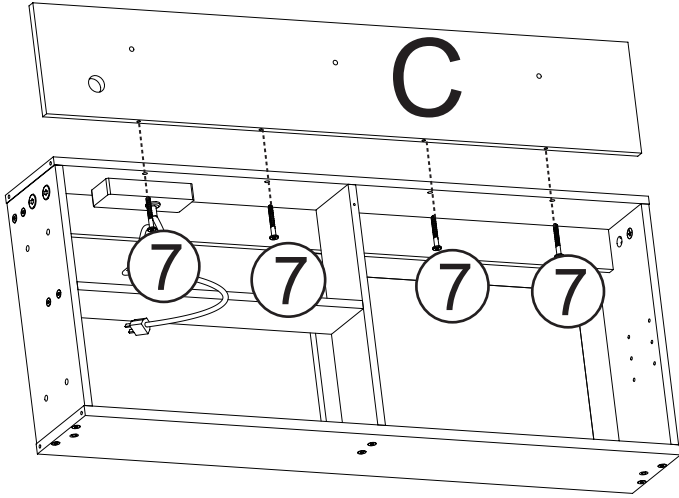

7 x 4

Step 12

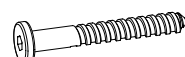
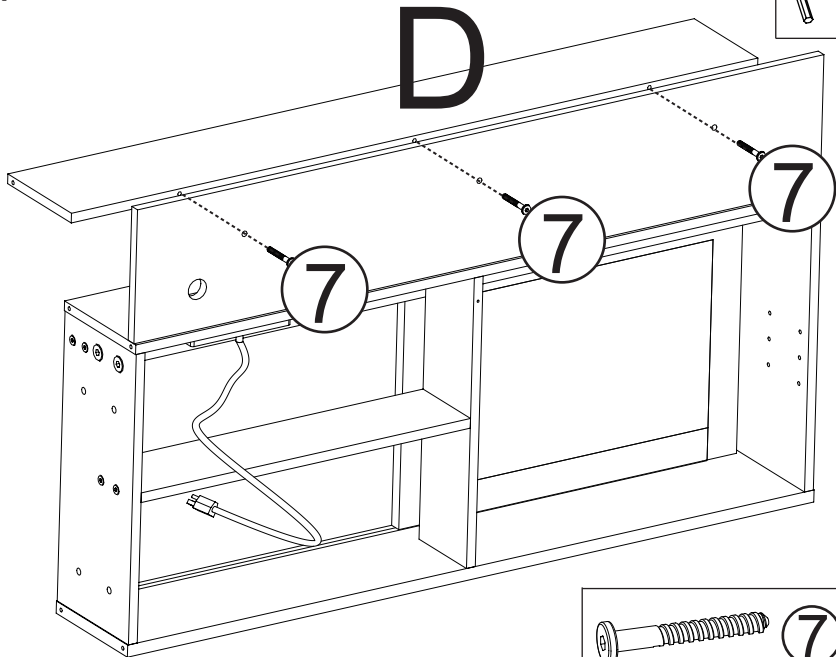

7 x 3

Step 13

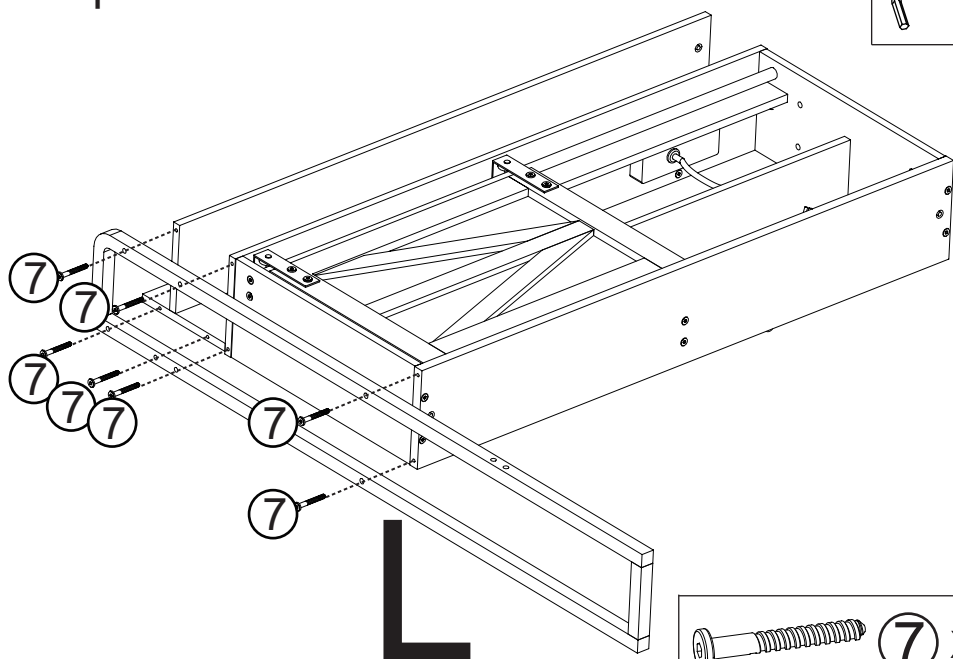

Step 14

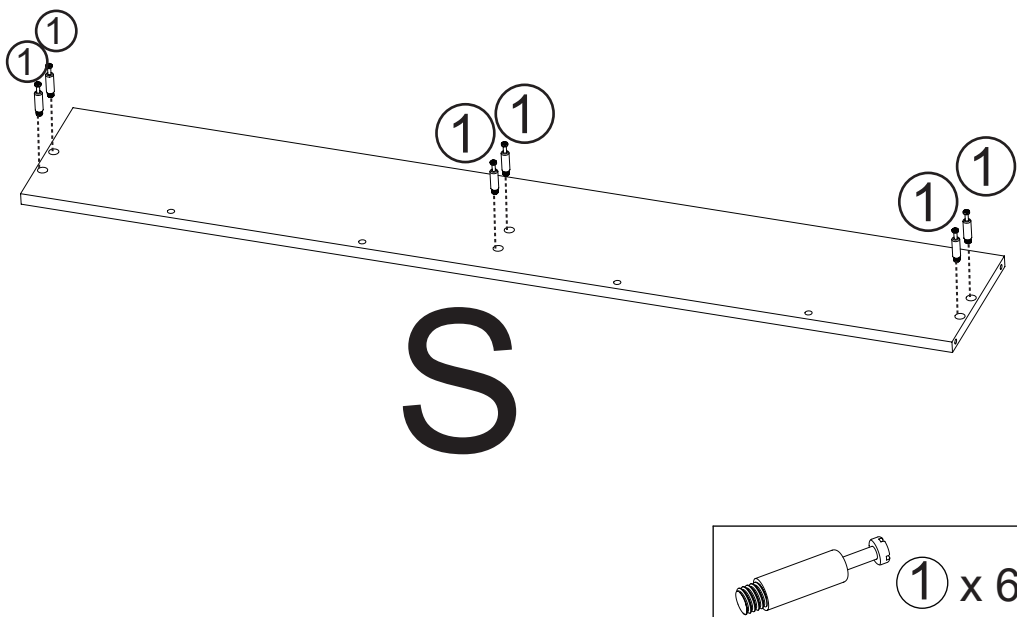

Step 15

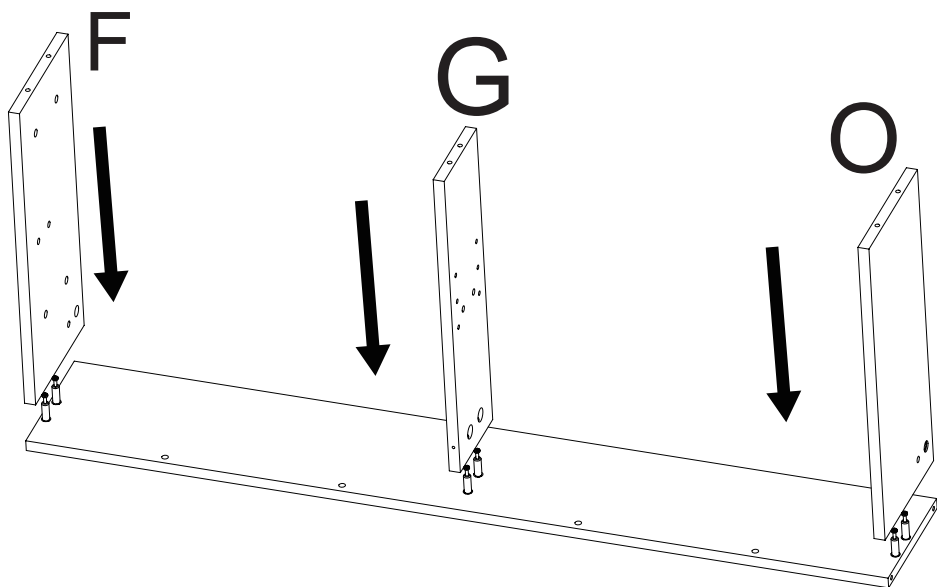

Step 16

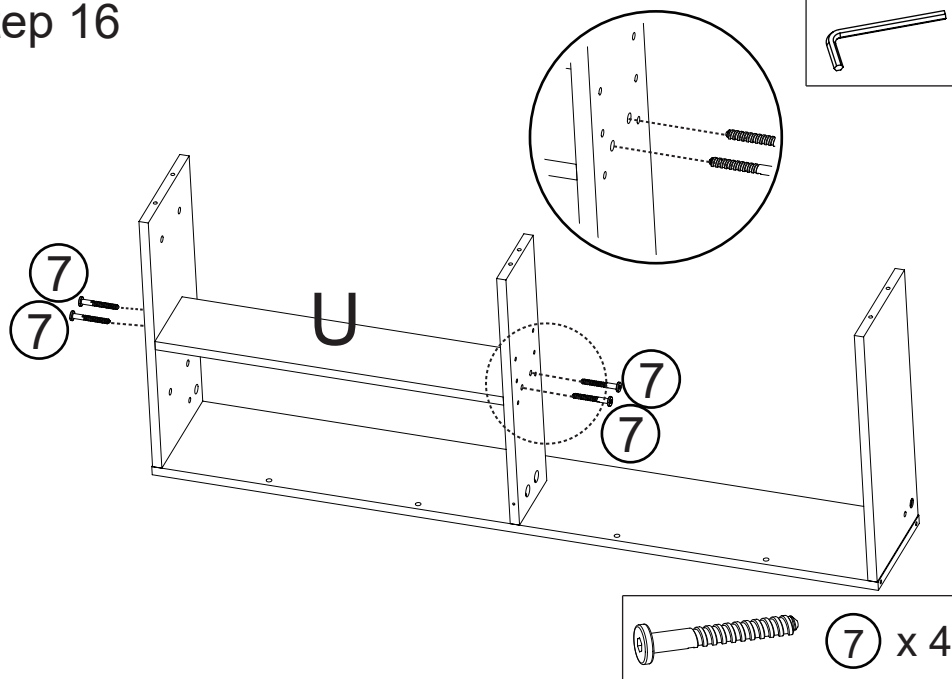

Step 17

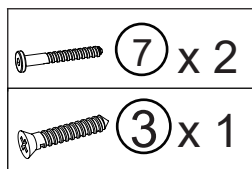
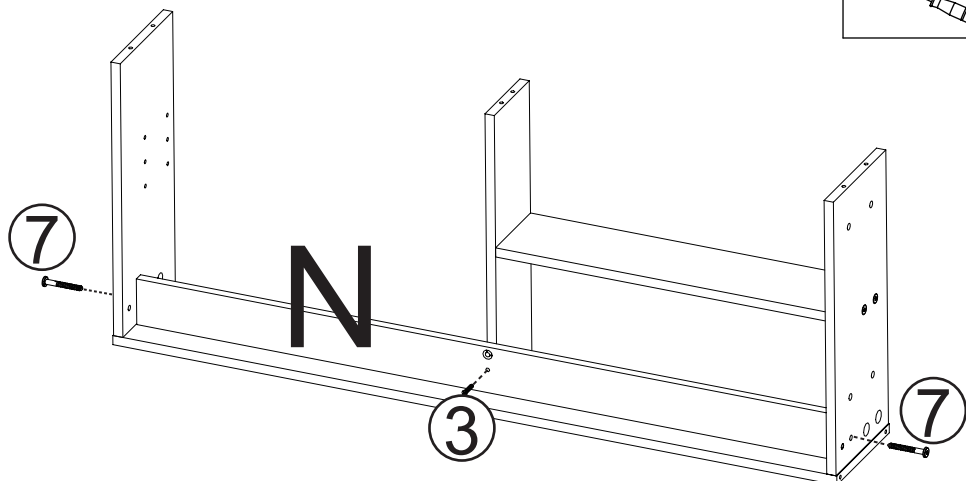
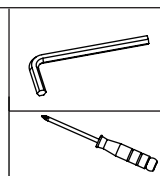

Step 18

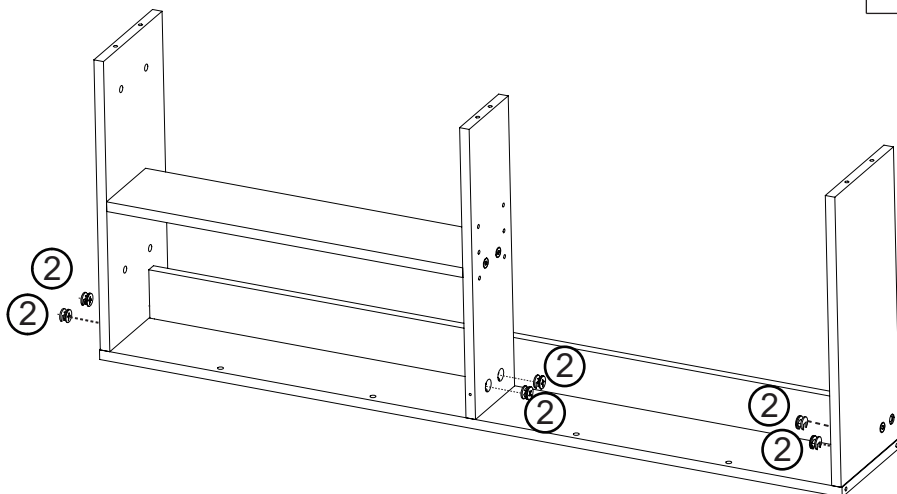
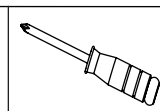

Step 19

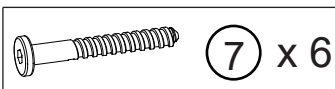
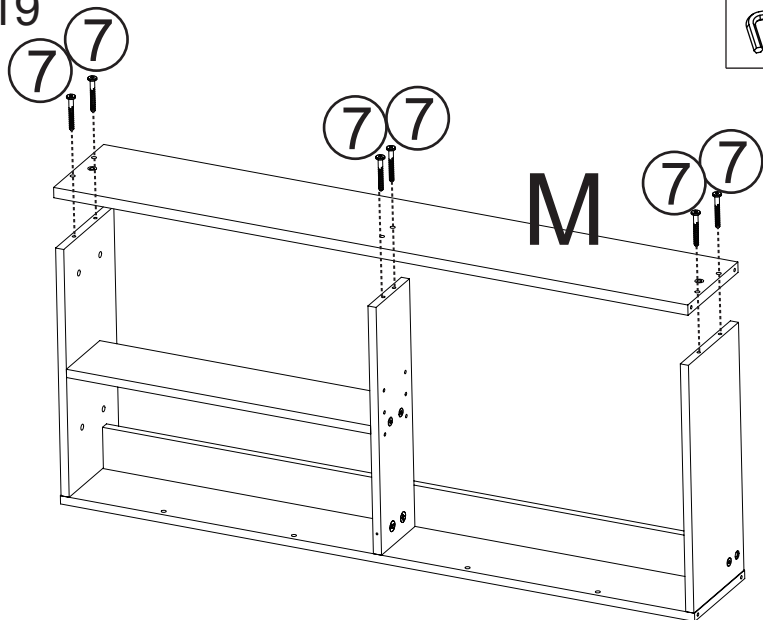

Step 20

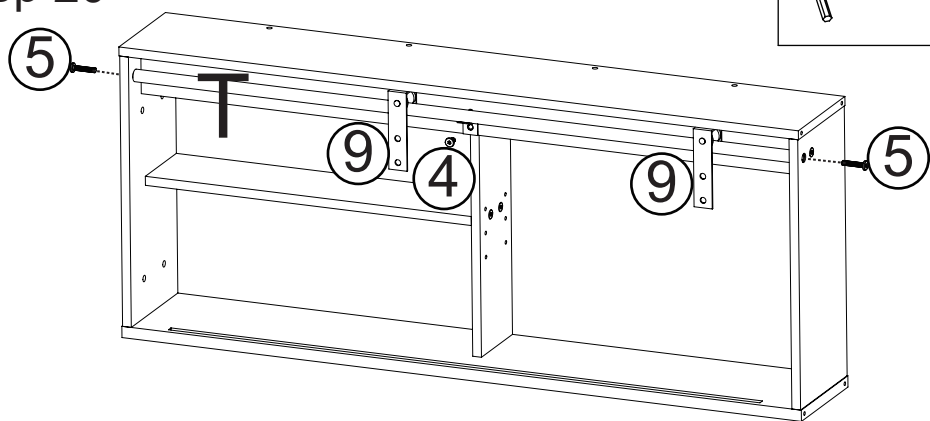

Step 21

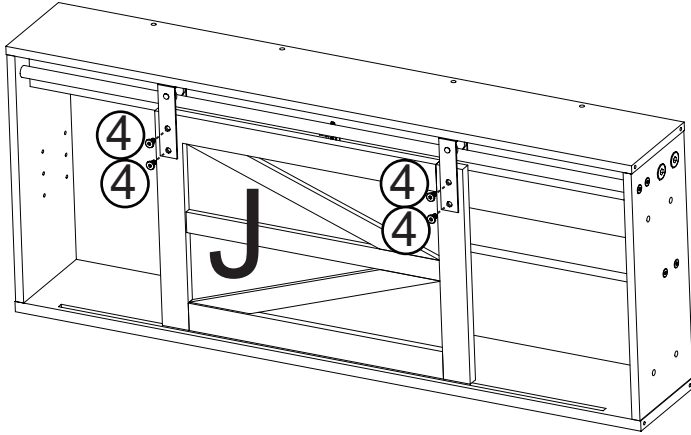

④ x 4

Step 22

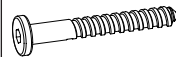
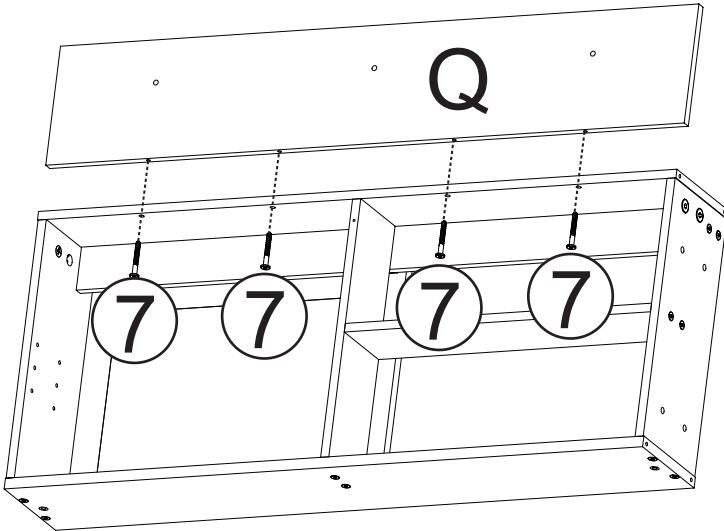

⑦ x 4

Step 23

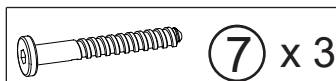
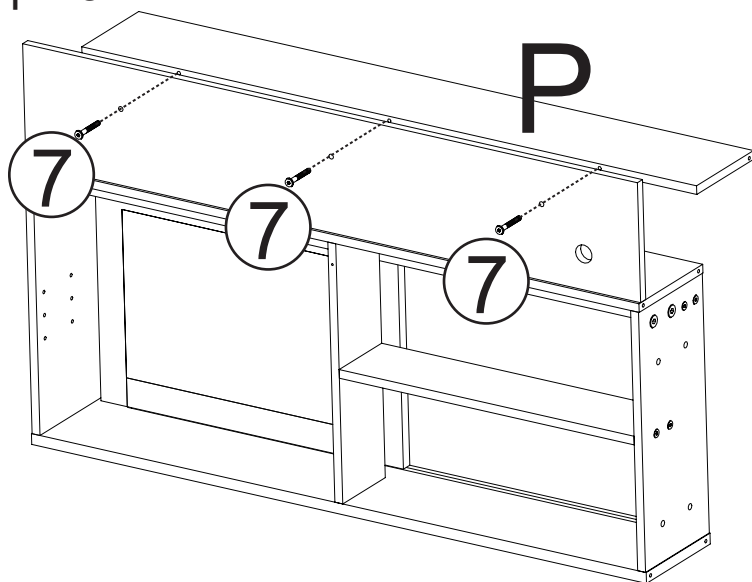

Step 24

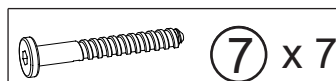
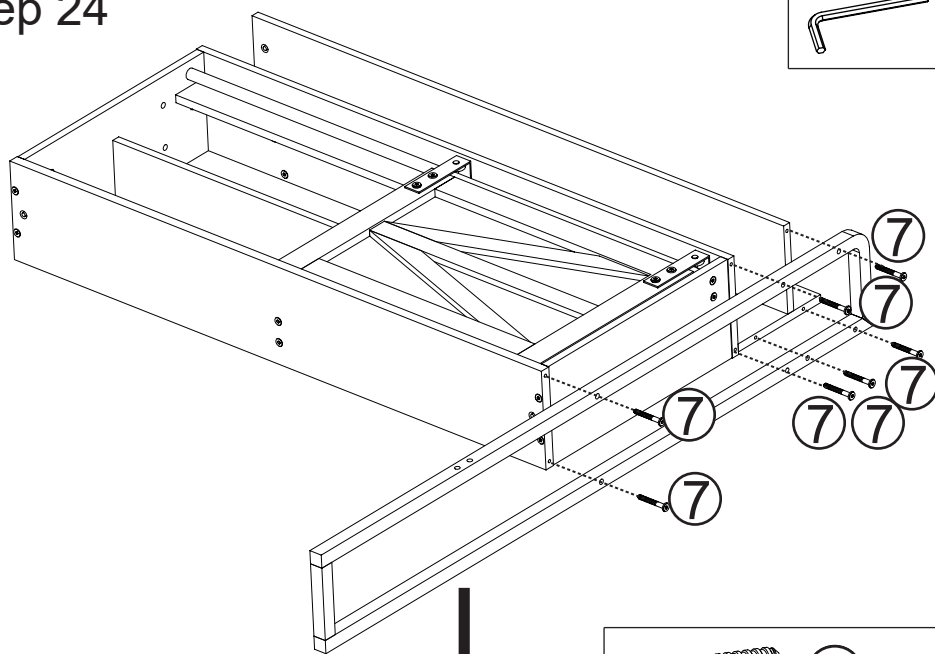

Step 25

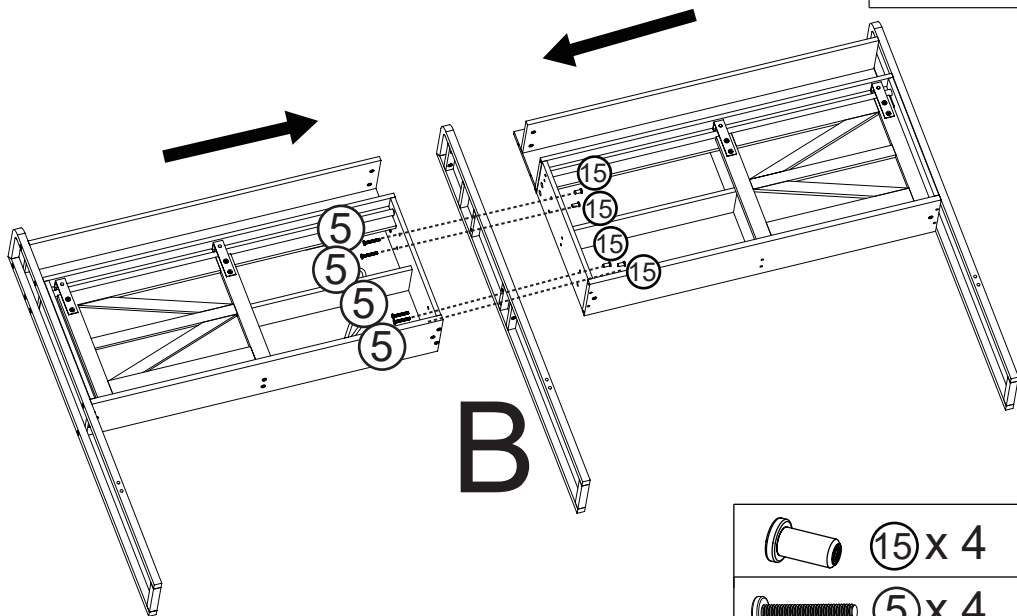
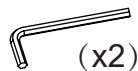

Step 26

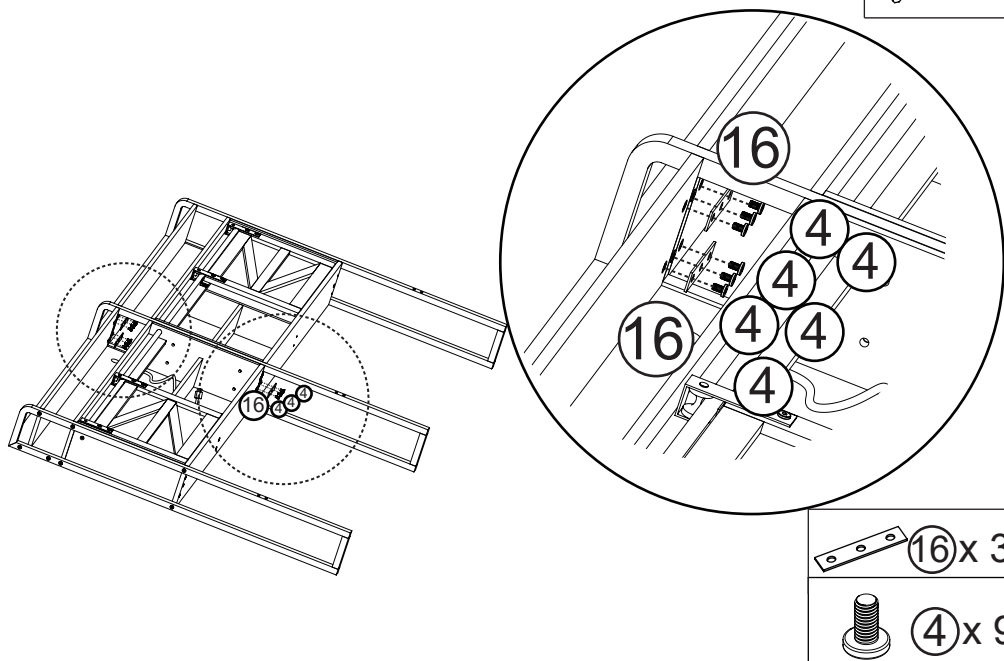

Step 27

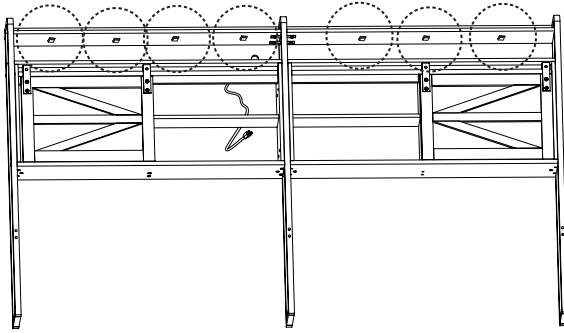

(1) In order to fix LED, choose an appropriate amount of clips based on your needs

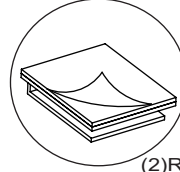

(2) Remove the sticker from the back of clip.

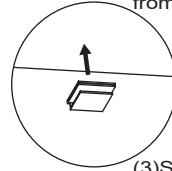

(3) Stick in a suitable position of J and K.



Step 28

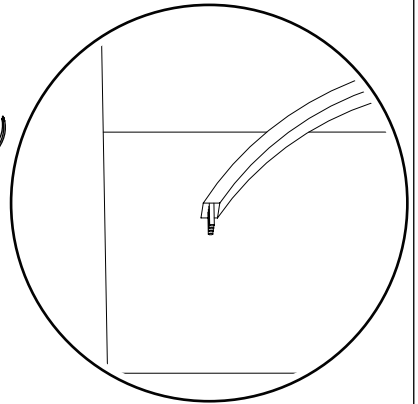
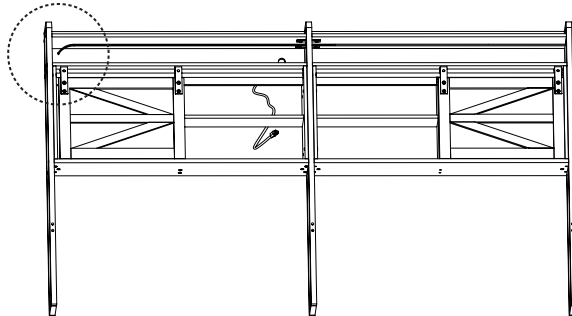
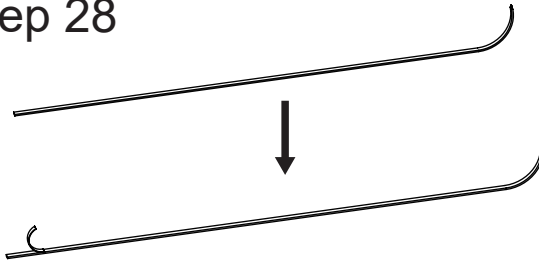

(1) Keep the plank dry and clean.

(2) As shown in the figure, paste the LED strip.

Step 29

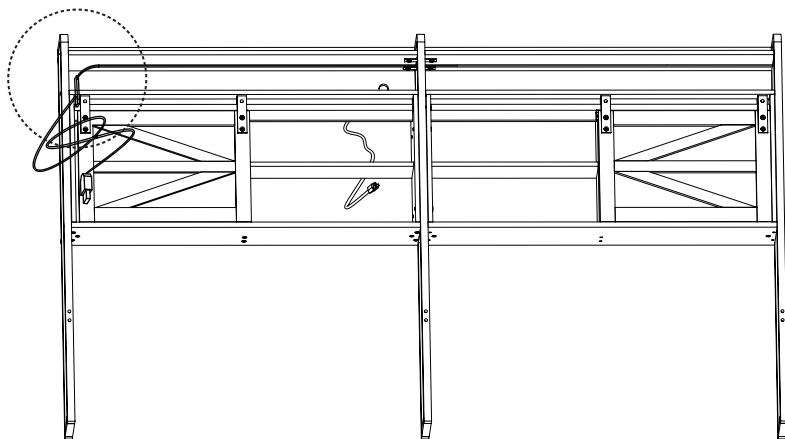

Conceal the plugs
as shown in the figure .

Step 30

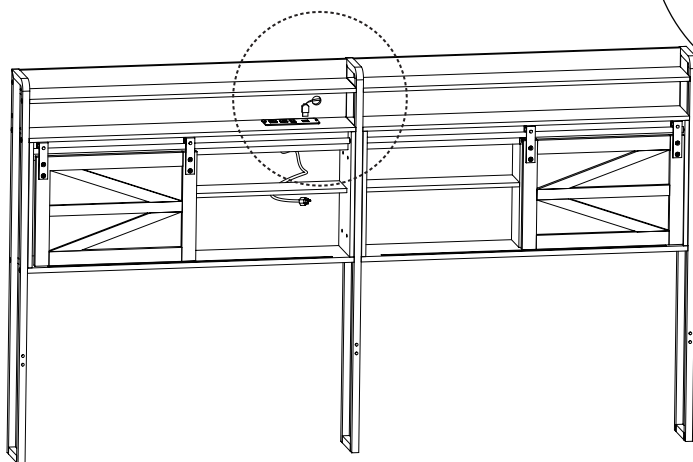

Step 31

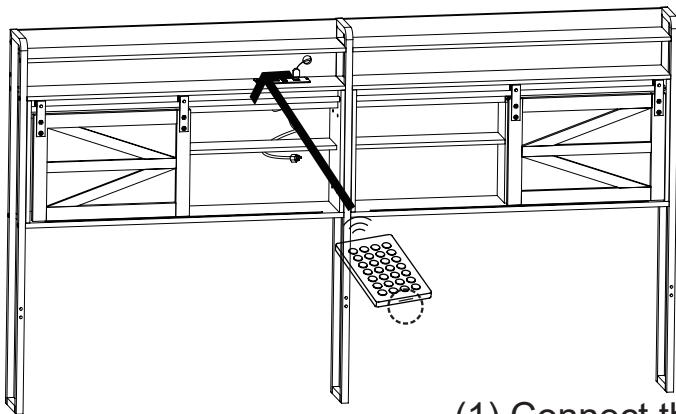

- (1) Connect the power source
- (2) Pull off plastic sheet at the bottom of remote control.
- (3) Aim at the receiver , turn on LED strip by remote control

Step 32

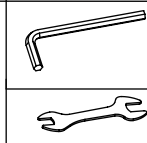
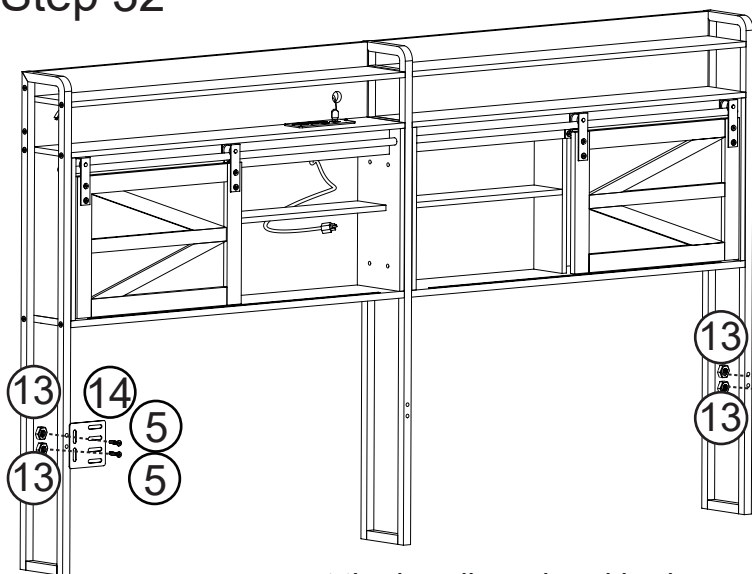

o connect the headboard and bed,
you can use Part 14 and screws to
complete the process

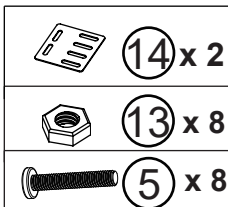
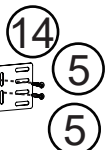

Step 33

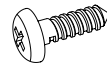
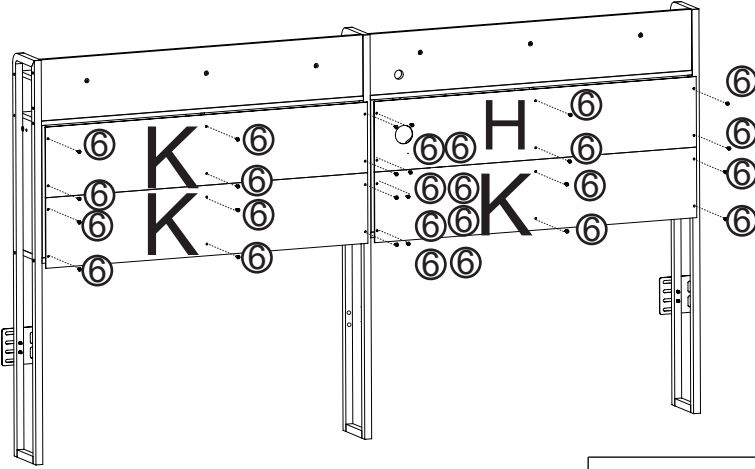
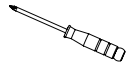

⑥ x 24

Step 34

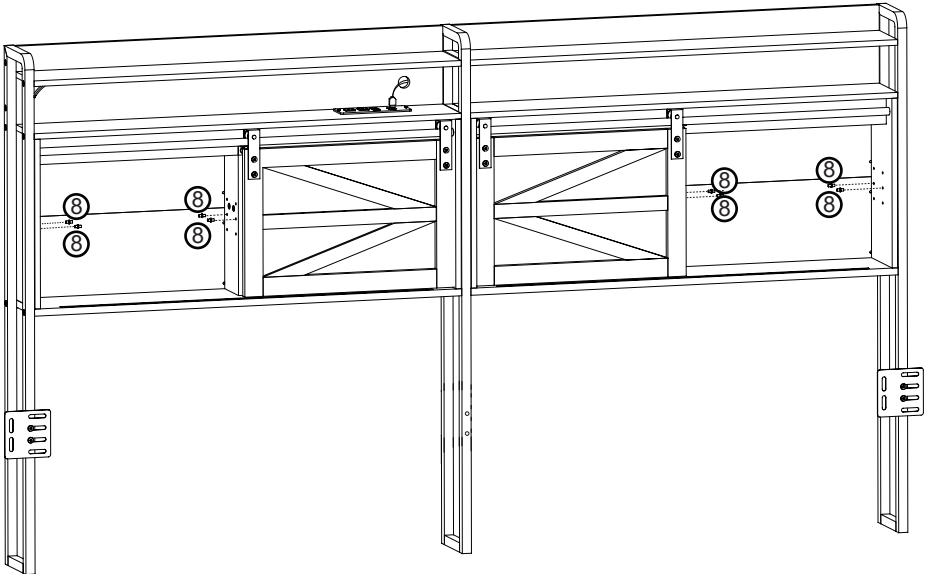

⑧ x 8

Step 35

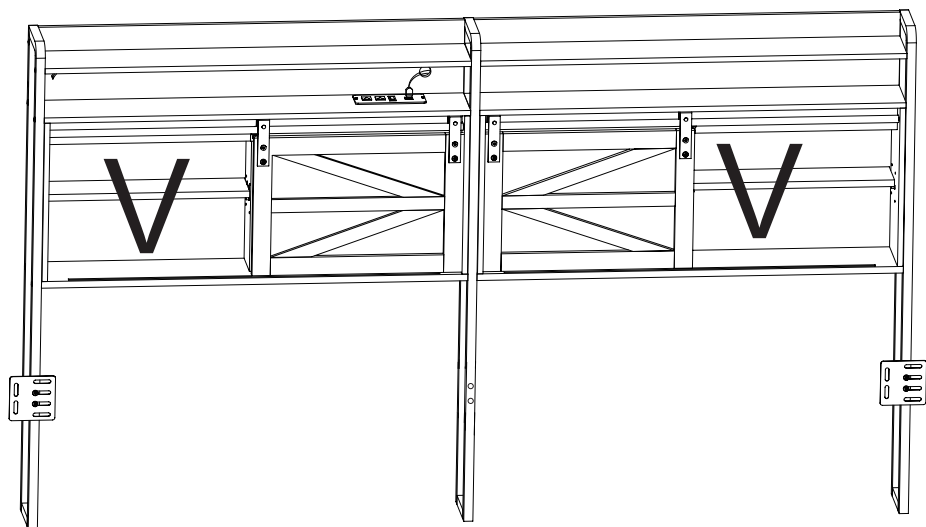

Step 36

