

# Assembly Instruction

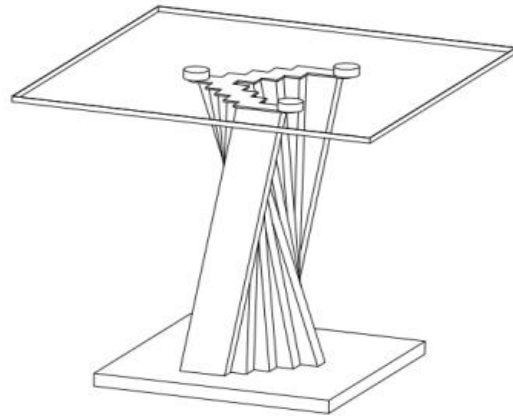

ASSEMBLY TIME PER UNIT:	20MINUTES
-------------------------	-----------

## PARTS IDENTIFICATION

### B1:TOP GLASS

**A TOP GLASS**

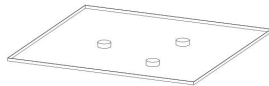

1pc



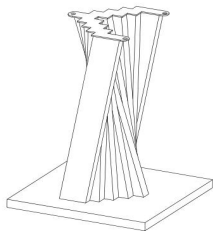

### B2:BASE

**B BASE**



1PC

### HARDWARE LIST

NO.	DESCRIPTION	FIGURE	QTY
1	Allen wrench 6MM		1
2	Bolts M6x10		3
3	spring shim		3
4	Flat washer		3

Hardware pack is located in BASE BOX

### STEP 1

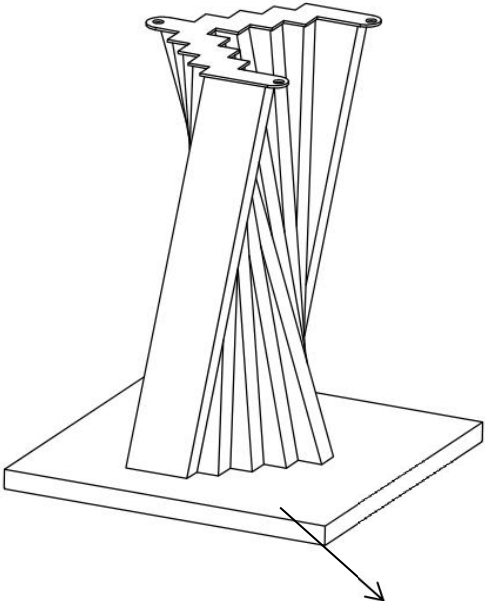

The diagram shows a square base labeled 'B:Base' with a central column of four slanted legs. The top of the legs is connected by a horizontal bar with a serrated edge. An arrow points from the text 'B:Base' to the base.

**B:Base**

### STEP 2

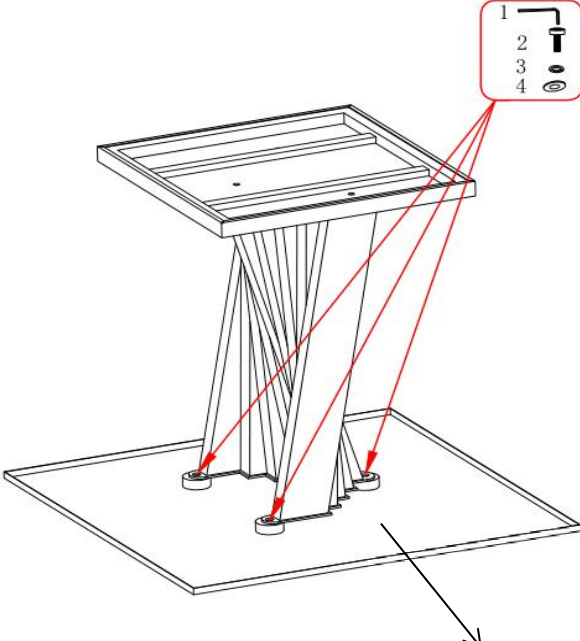

The diagram shows the base from Step 1 with a square top glass labeled 'A:Top Glass' being placed on top. Red arrows point from the glass to the base. A legend box in the top right corner contains a list of parts: 1 (L-shaped bracket), 2 (screw), 3 (washer), and 4 (nut). Arrows from the legend point to the assembly points on the glass and base.

**A:Top Glass**

### STEP 3

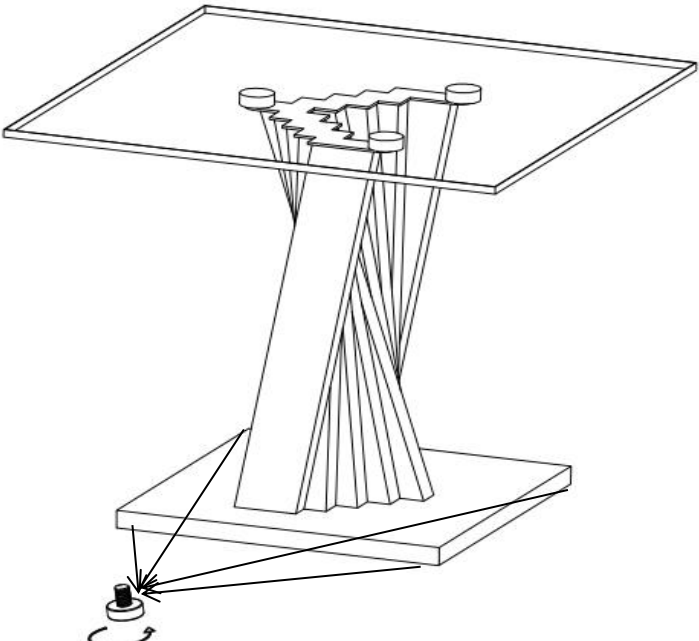

The diagram shows the fully assembled table. A callout shows an adjustment foot being fixed into the base. Below the diagram is the text 'ADJUSTMENT FEET FIXED IN BASE'. To the right are two icons: one with a crossed-out person and another with two people holding a table.

ADJUSTMENT FEET FIXED IN BASE