

Assembly Instruction

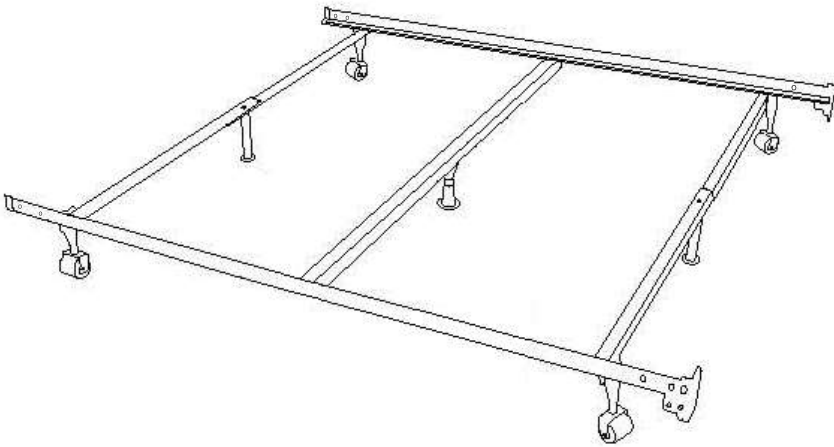

Important Notice:

This item designed to universal for TWIN/FULL/QUEEN three size,
Please follow the steps to get your desired size; Make sure the
Center Support Bar are correctly assembled see Details in **Step 3**

Parts List

Parts ID	Image	Description	Qty
A		Side rail with cross bar (left)	1
B		Side rail with cross bar (right)	1
C		Center Support Leg	2
D		Plastic Corner Pad	2
E		Wheel Without Brake	2
F		Wheel With Brake	2
G		Center Support Bar	1
H		Glide	1
Hardware Parts			
Parts ID	Image	Description	Qty
1		Bolt 15mm	2
2		Bolt 25mm	2
3		Washers	2
4		Nut	2
5		Wrench	1
6		Allen Key	1

TWIN/FULL/QUEEN ASSEMBLY

Step 1 Swing out cross arms to 90 degrees.

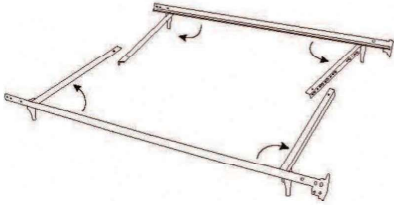

Step 2 Place rivets of the cross arms into appropriate key holes then slide to lock as shown in Figure 1.

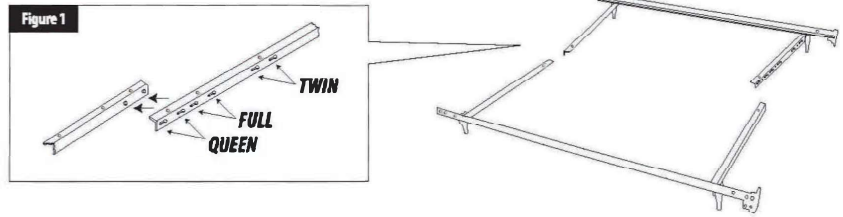

Step 3 Attach center support with bolt (2), nut (4) and washer (3) as shown in Figure 2 (Side-to-side for queen size and diagonally for full size and twin size). Use tool 5&6

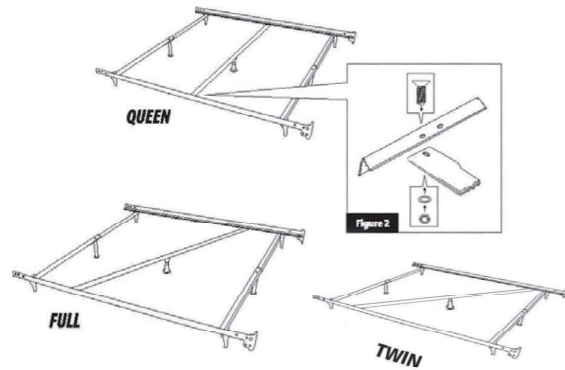

Step 4 Install wheels and glide as shown in Figures 3 and 4.

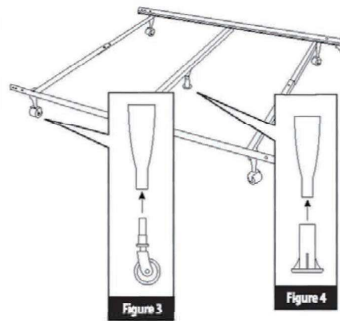

Step 5 Place support legs under holes that align on center of cross arms. Screw in as shown in Figure 5. Use bolts NO1

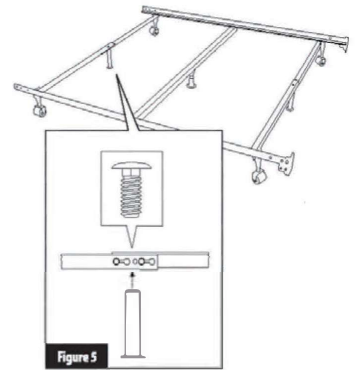

Step 6 Put the plastic corner pad to the end of the side rails shown in figure 6

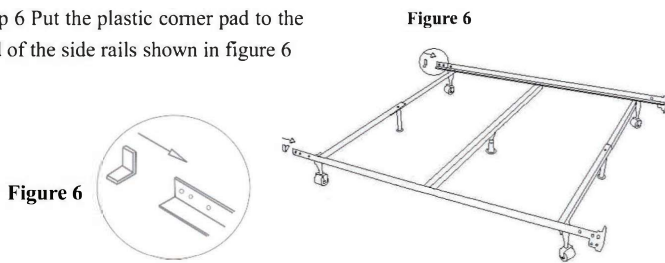

Finish

Important Warnings:

Always use the center legs to
Increase the weight capacity
for the whole set, when moving
the bed, please make sure the center
support legs are not bent by the flooring

