

Assembly Instructions

Caution : You must read this before you proceed

Push Back Chair

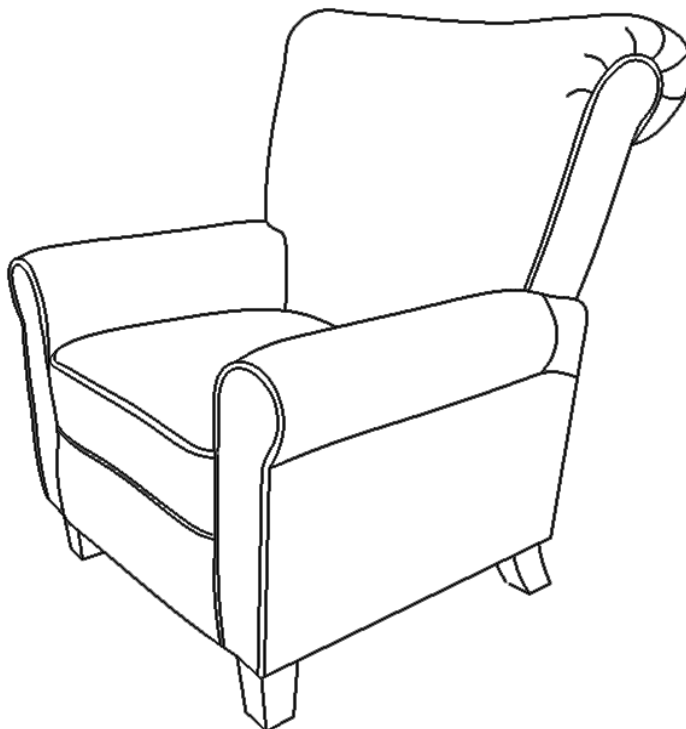

Parts List

Label	Picture	Description	QTY (pc)
A	A line drawing of the backrest part of the chair, showing the curved backrest and the armrests.	Backrest	1
B	A line drawing of the chair base with footrest, showing the seat, armrests, and the integrated footrest.	Chair Base With Footrest	1

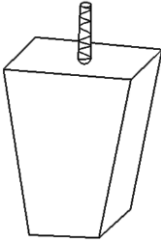
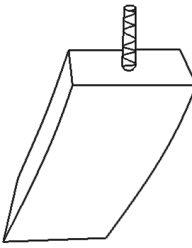
C		Front Leg	2
D		Hind Leg	2

Hardwares List

Label	Picture	Description	QTY (pc)
①		Gasket	7

Assembly Preparation

Before Beginning Assembly:

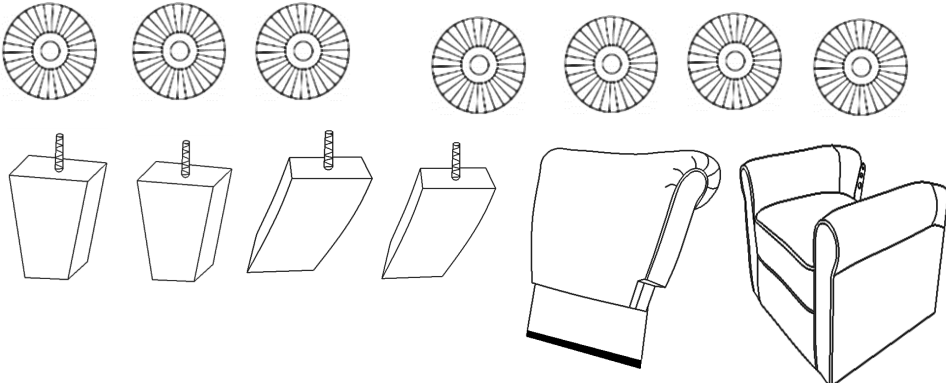

- Read instructions, cover to cover-



- Have 2 adults on hand for assembly-



- Do not assemble on flooring or carpet-



- Assemble on a clean non-marring surface (packing foam)-



- Save all packaging until finished-

Assembly Steps

Parts Introduction

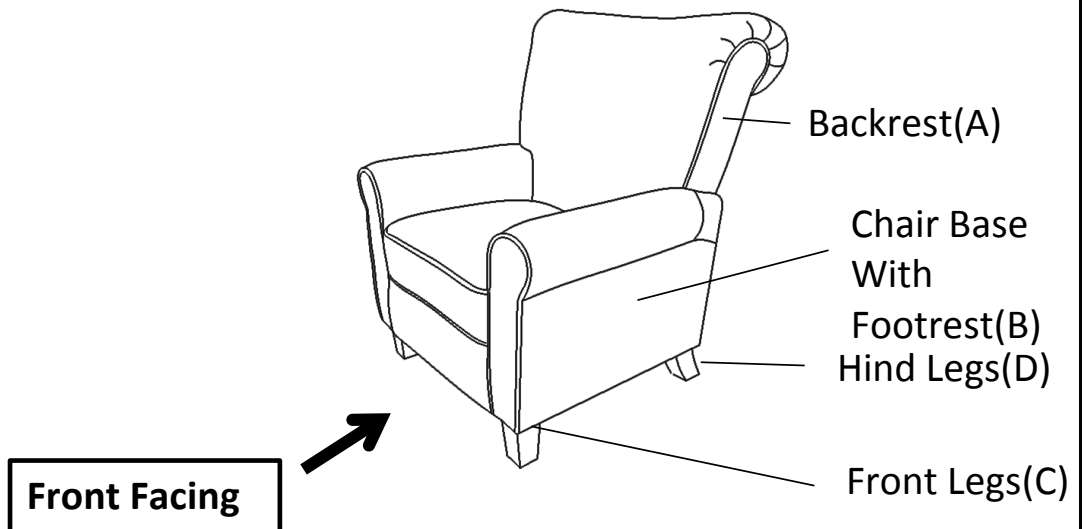

This product has multiple parts and may require up to some 30 minutes to assemble. To give you an overview of the product parts, the above picture is to help you put the various parts into perspective. Please read through the instructions below to familiarise yourself with the parts and steps before assembly.

Step 1

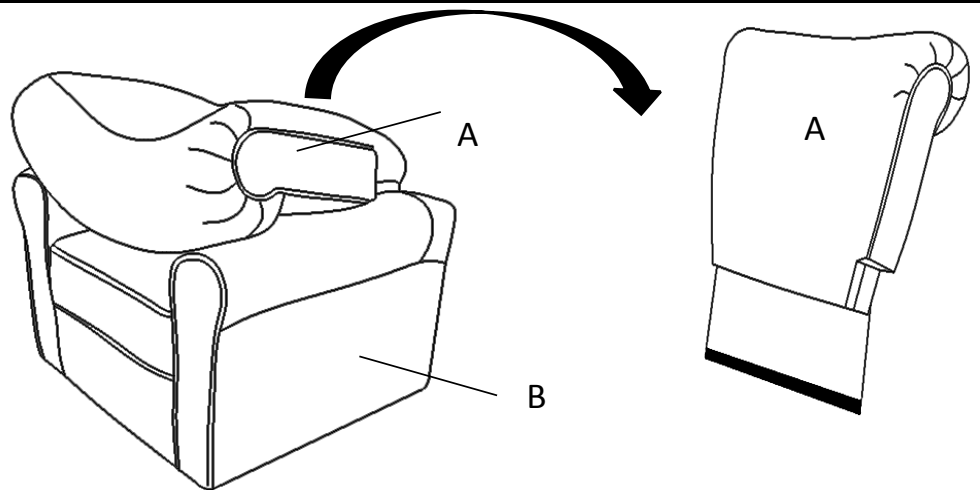

Take out the Backrest(A) from the Chair Base with Footrest(B).

Step 2

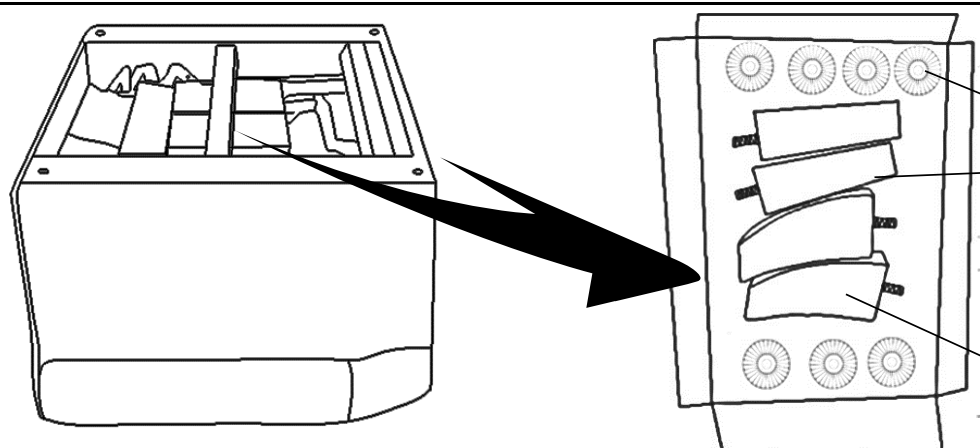

Place the Chair Base with Footrest(B) facedown on a clean,non-marring surface. Open the non-woven bag and take out the Front Legs(C), Hind Legs(D) and Gasket(①) .

Step 3

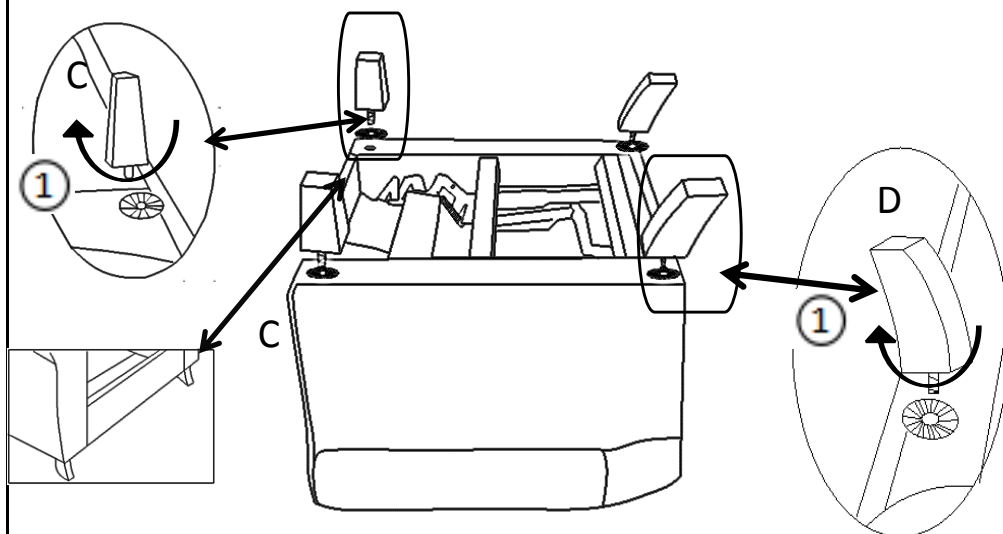

Install the Front Leg(C) and Hind Leg (D) at the bottom of the Chair by placing one Gasket(①) on the threaded stem. Then insert threaded stem into the mounting position at the corner of the Chair.

Tighten by turning the Leg clockwise.Do not over tighten.

Repeat the same process to install the remaining two Legs.

Take care of the shape of the Legs and ensure they in the correct positions.

Note: The use of Gaskets are OPTIONALand are especially useful to help alleviate slight wobbleness. Some Legs may need more than one gasket whilst some Legs may not need any.

Step 4

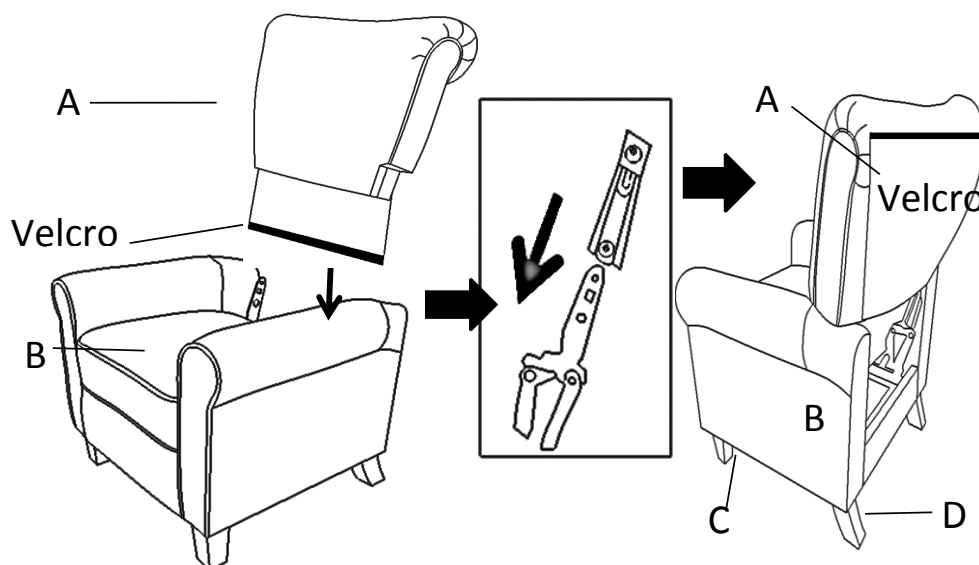

With assistance from your adult partner, hold up the Chair Backrest(A) while standing behind the Chair.

Insert the small metal arms on the sides of the Chair Backrest(A) into the prefabricated slide lock gadget on the Chair Base with Footrest(B) as shown above.

Firmly but gently, push the Chair Backrest(A) downwards until the Chair Backrest(A) is fully slotted and locked into position.

Step 5

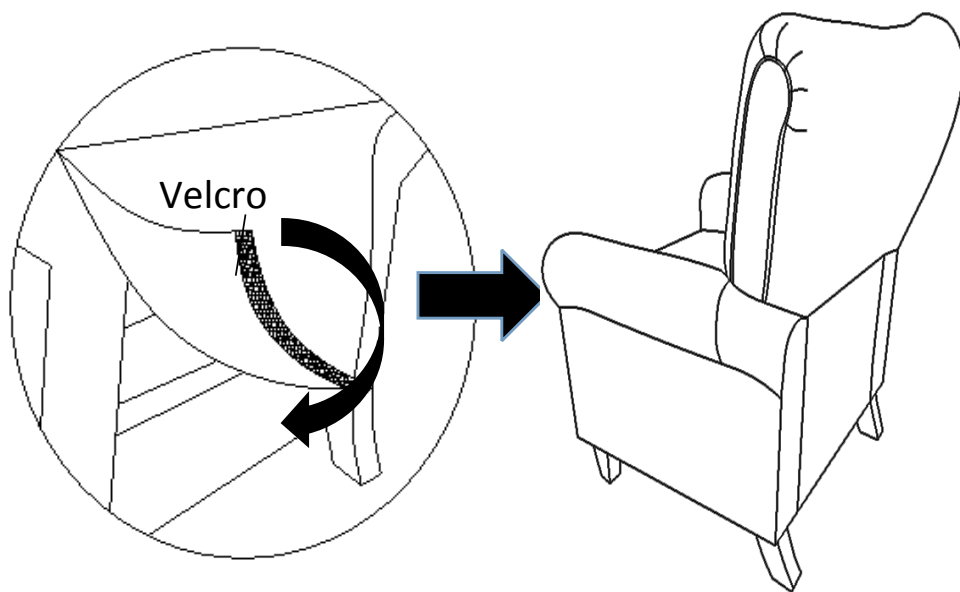

Smooth down the fabric flap on the Chair Backrest(A).

Run your hands down both sides of the flap, from top to bottom, allowing the velcro tape to adhere to the flap under the seat of the Chair.

Step 6

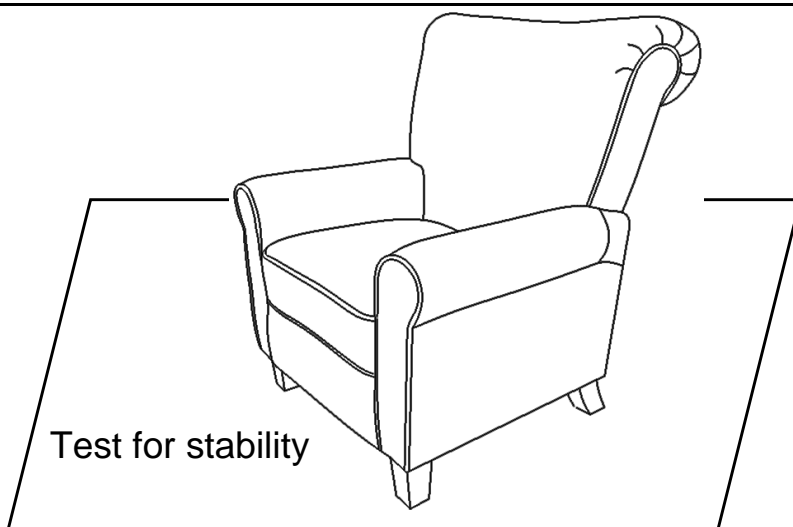

Make sure all parts are connected and securely locked into position.
Position Chair right side up and test for stability.
Your Chair is ready for use.
Caution: This Chair can only be used on a flat, level surface.

Step 7

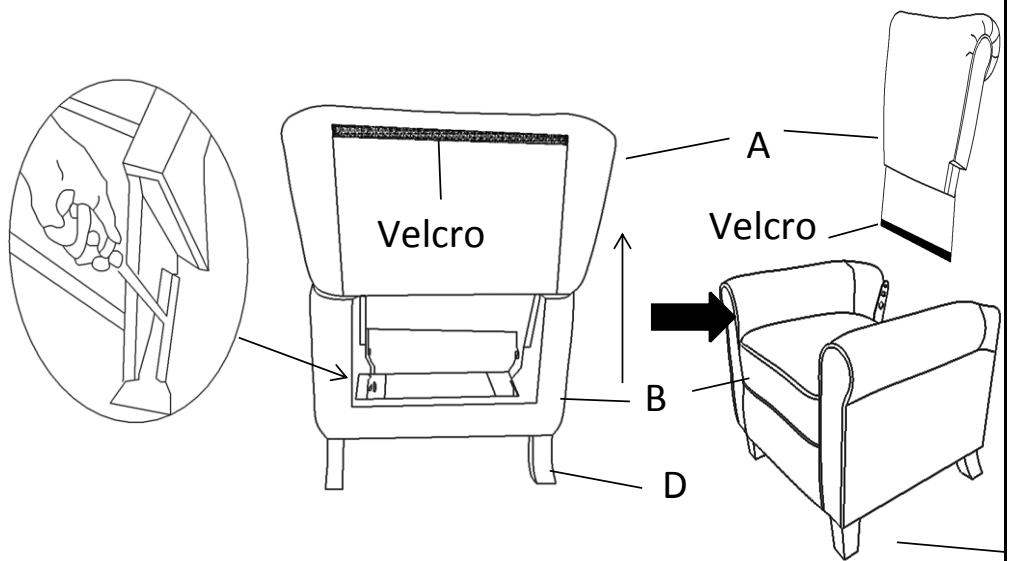

Disassembly Note: open the flap on the Chair Backrest(A), use a screwdriver(Don not use fingers) pressing outward on the metal ear on the preattached Metal Bracket on one side of the Chair Base(B), with assistance of you adult partner to keep the Chair Base(B) in place, pull out the Chair Backrest(A) upward at the same time, repeat the same step for another side. Then the Chair Backrest(A) can be taken out.

User Instructions.

Push Back Chair

Please read the Instruction Manual below carefully before use.

Supervise children, when in use of this Push Back Chair.

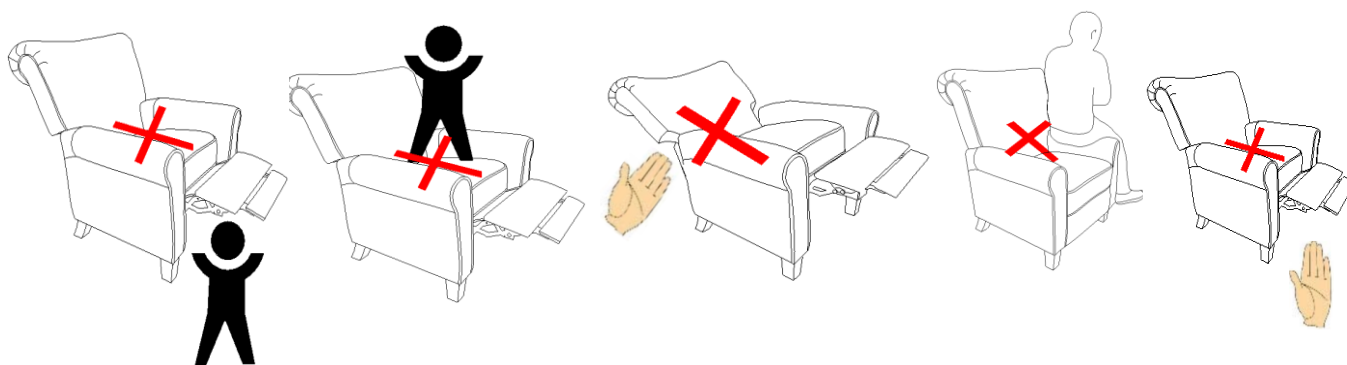

Do not allow children to play on the chair.
Always leave the chair in an upright and closed position after use.
Keep hands and feet clear of the footrest mechanism and any gaps.
Just push it by your feet.
Don't sit any armrest of chair.

To get into a open position-To push the Chair Backrest

Sit into the seat.

The Chair Backrest will fall down and footrest will open when push the Chair Backrest by your back. So do must put your feet on footrest well when you push down the Chair Backrest. Open the trigger on the outside of right armrest.

Use your body weight and push backwards into the seat into a fully reclined position.

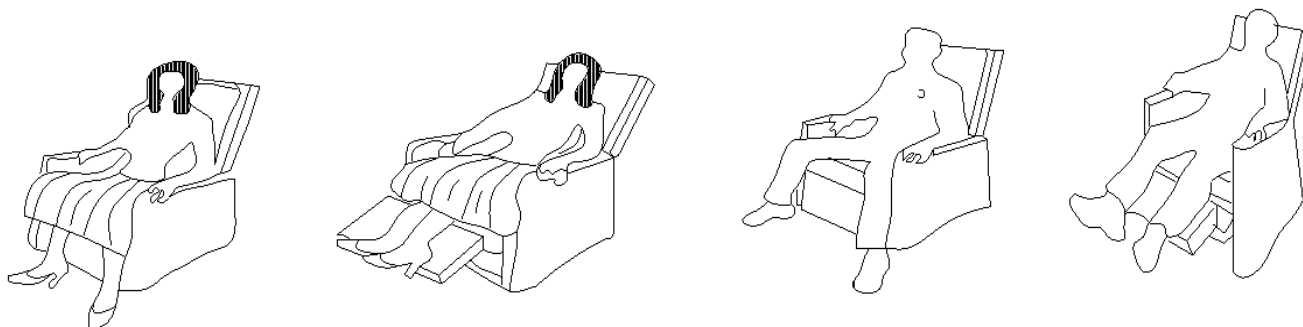





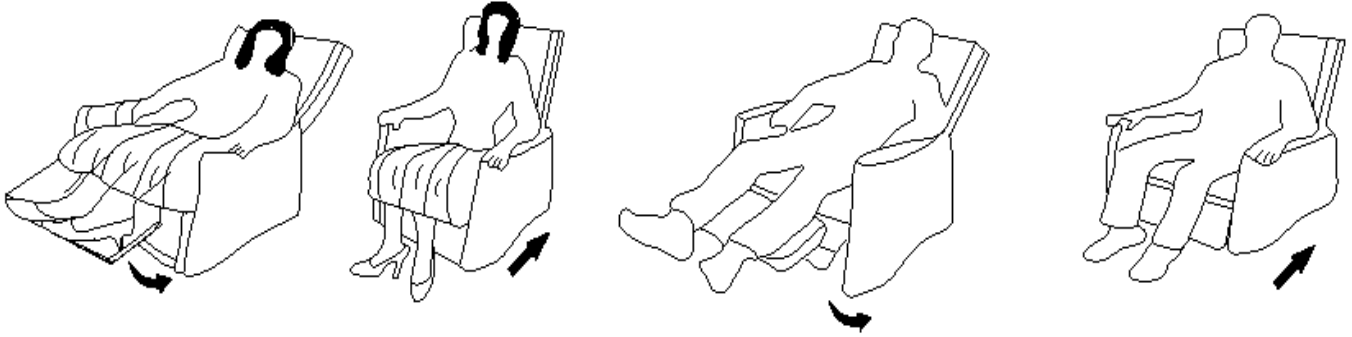





to get out of chair-move Seatback into Upright Position

Tilt your body weight slightly forward and upwards.
The seat back will come up to an upright position.
Use your feet to push the footrest down.
The Chair will automatically lock when it is in the fully upright position.
Where necessary, use your arms help lift/push yourself out of the seat



Care & Maintenance

-  ● Do not put hot items directly on furniture surface
-  ● Do not clean furniture with harsh cleansers or polish.
-  ● Do not place furniture under direct sunlight.
-  ● Do not place furniture near heating or cooling vents.
-  ● Do not write on furniture without a padded barrier to protect the surface.
-  ● Do not place furniture outside . For indoor use only .
-  ● Not for commercial use. For residential use only .
-  ● Stains may be removed with mild soap solution and damp cloth.
-  ● Children should not climb or jump on the furniture.

-
-  ● Dust and pick-up spills using a clean, non-colored, lint-free cloth .

What is Proposition 65?

Proposition 65 is a California law that requires warning labels on products that may contain one of more than 800-plus chemicals or ingredients that the California Office of Environmental Health Hazard Assessment (OEHHA) has deemed to cause cancer or other reproductive toxicity.

Chemicals and elements on this list include wood dust, brass, and other everyday substances, which can be found in very common household items, such as: lamps, tableware, jewelry, crystal glasses, electric cords, beauty products, automobiles, and furniture.

Why Did I Find a Proposition 65 Warning on My Home Goods Product?

We include Proposition 65 warnings on all of our products because there is always a chance that one of the 800-plus common chemicals and ingredients listed under this law could potentially be on our furniture or packing materials. We risk large fines under this law, if we don't include this warning.

Should I worry?

We realize you may be worried finding this warning on our products, but we want to reassure you that the hazardous exposure limits for any of these chemicals have never been found on furniture products that we've shipped to our customers. Additionally, this warning label is very common and can be found on almost every piece of furniture sold in the state of California.

Just How Common Are Proposition 65 Warnings?

Proposition 65 warnings have become so common in California that it is hard to take a trip to a local bank, grocery store, or restaurant without finding at least one warning. In fact, even the Disney Land Resort has a Proposition 65 warning:

