



W1 : 10x40mm(8pcs)



W2 : 10x85mm(9pcs)



W3 : 6x35mm(6pcs)



W4 : 10x25mm(1pc)



W5 : (4pcs)

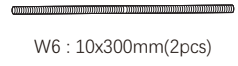

W6 : 10x300mm(2pcs)



N1(1pc)



N2(1pc)



N3(1pc)



5mm(1pc)



W7 : 25mm(4pcs)

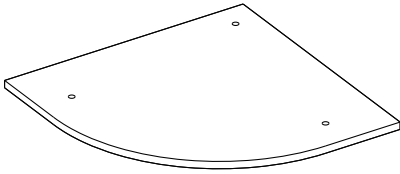

A 480*480*12mm(1pc)

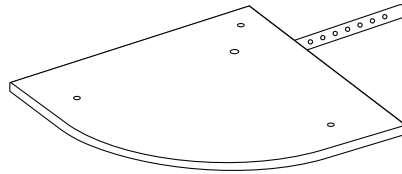

B 480*480*12mm(1pc)

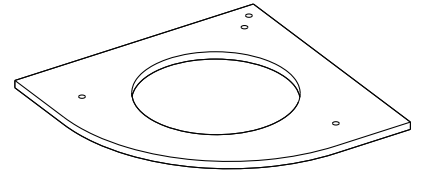

C 480*480*15mm(1pc)

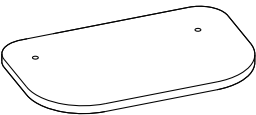
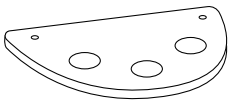

D 390*270*12mm(1pc)
390*240*12mm(1pc)

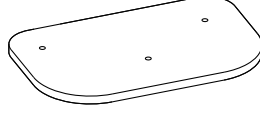
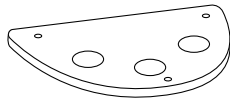

E 390*270*12mm(1pc)
390*240*12mm(1pc)

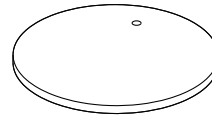
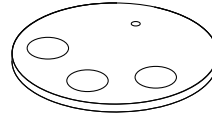

F Φ 330*12mm(1pc)

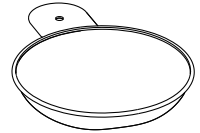

G Φ 300mm(1pc)

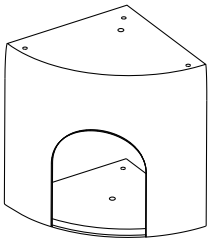

H 300*300*12mm(1pc)

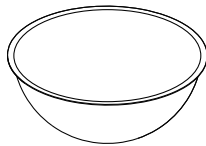

I Φ 300mm(1pc)

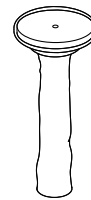

J (2pcs)

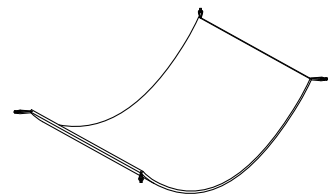

K (1pc)

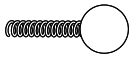

L (1pc)

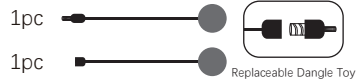

M



N Φ 70*9mm(2pcs)

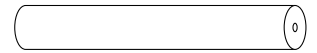

O 395*53.5mm(1pc)



P 615*53.5mm(2pcs)



Q 615*53.5mm(4pcs)



R 300*53.5mm(4pcs)



S 395*53.5mm(1pc)



T 300*53.5mm(2pcs)

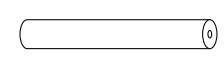

U 280*30mm(3pcs)

1

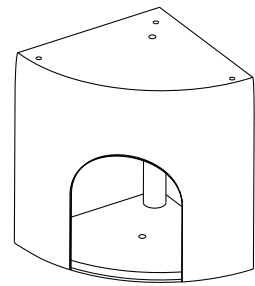
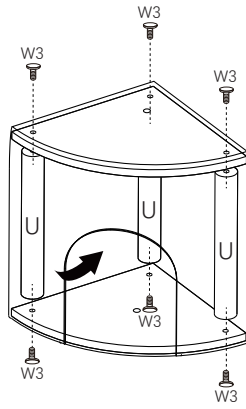
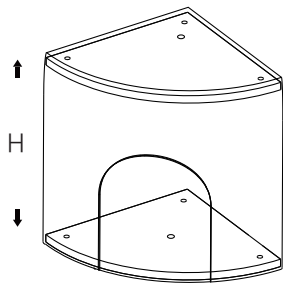

2

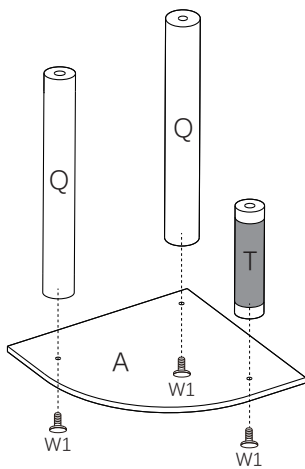

3

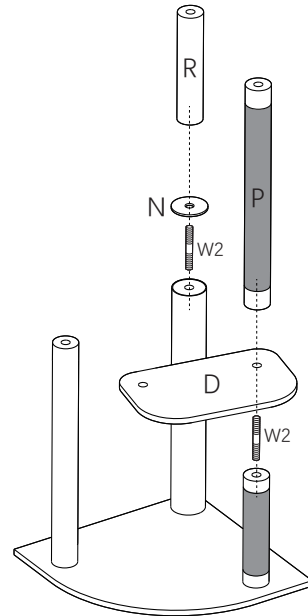

4

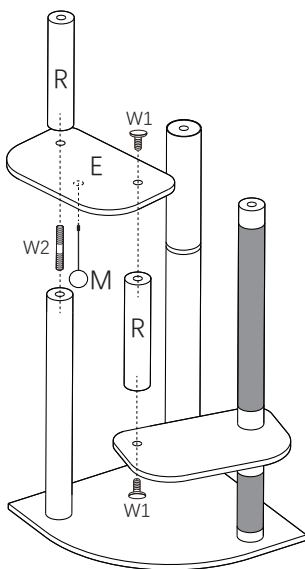

5

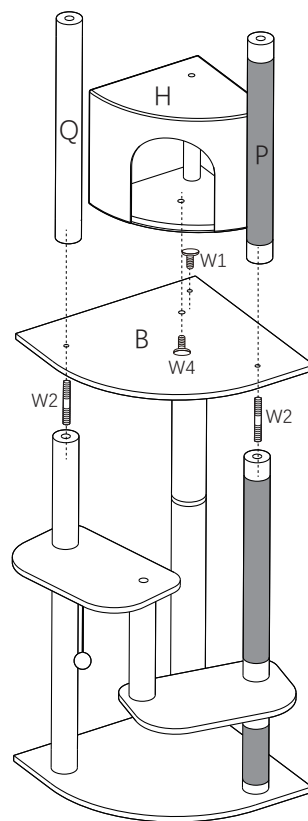

6

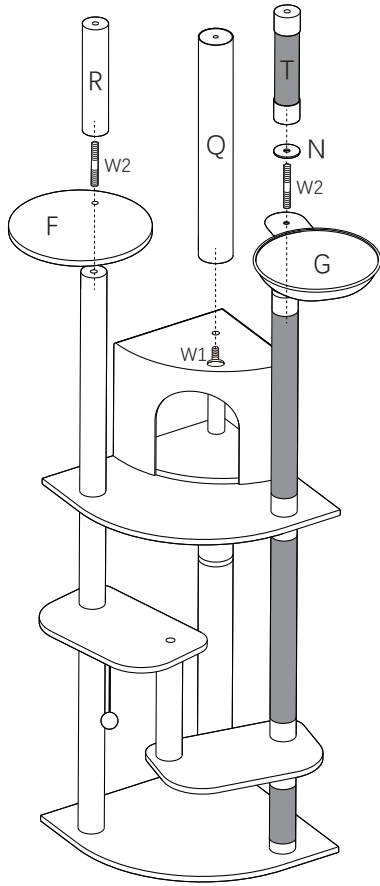

7

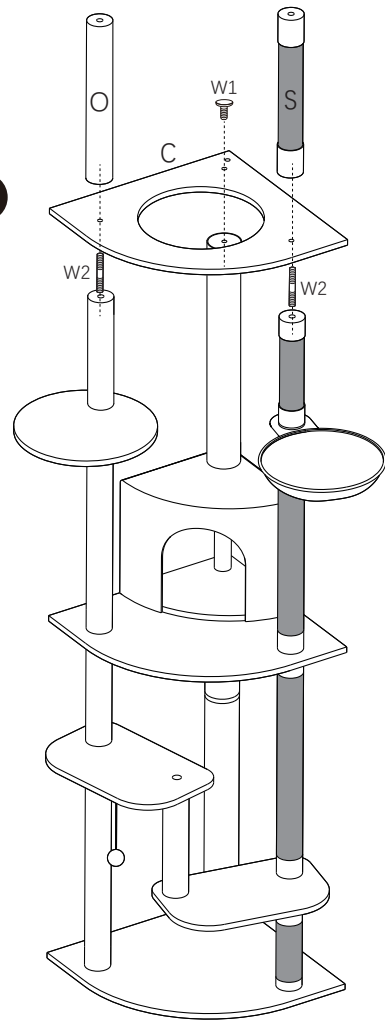

8

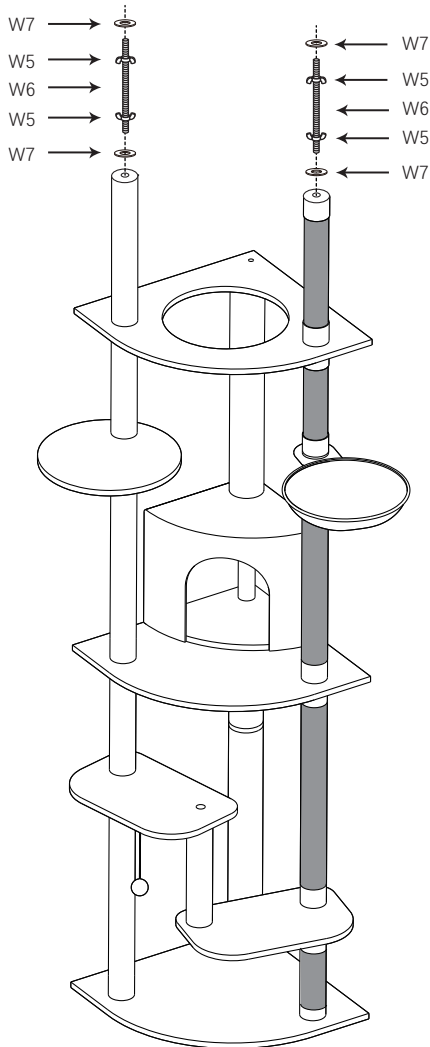

9

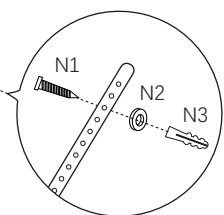
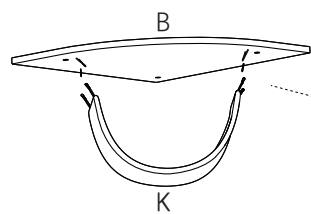
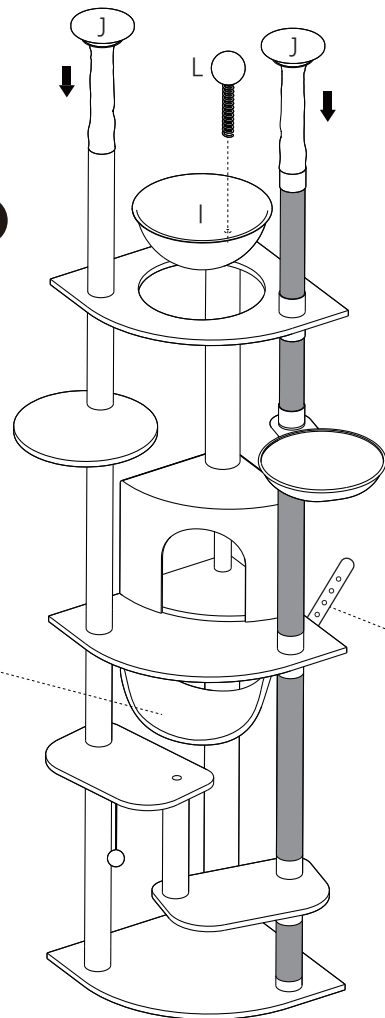

PRODUCT SAFETY INSTRUCTIONS

EN

Installation Check

1. Vertical Alignment: Ensure the cat tree is upright.
2. Tightening: Secure all parts and screws tightly, especially the top parts against the ceiling.
3. Accessory Check: Verify all are used correctly. Contact us if any are missing or damaged.

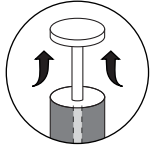

Use Anti-Tip Chain

Double security: Secure the included anti-tip chain to the wall to prevent tipping.

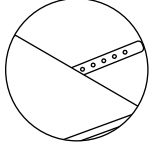

Tipping Risk Warning (Small probability & inevitable)

1. Placement: Keep the cat tree away from valuable items like TVs and artworks.
2. Regular Checks: Frequently check the stability and condition of all parts.



For any issues, contact our customer service team.

Installationsüberprüfung

1. Vertikal: Sicher sein, dass Kratzbaum aufrecht steht.
2. Festziehen: Ziehen Sie alle Teile und Schrauben fest an, insbesondere die oberen Teile gegen die Decke.
3. Zubehörprüfung: Sicher sein, dass alle Teile nicht mangelhaft sind und korrekt verwendet werden.

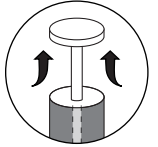

Verwendung von Anti-Kipp-Kette

Doppelte Sicherheit: Anti-Kipp-Ketten an der Wand befestigen, um Umkippen zu verhindern.

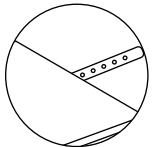

Warnung vor Kippgefahr (geringe Wahrscheinlichkeit & unvermeidlich)

1. Platzierung: wertvolle Gegenständen wie Fernsehern und Kunstwerken fernhalten.
2. Regelmäßige Überprüfungen: die Stabilität und den Zustand aller Teile.



Bei Problemen wenden Sie sich bitte an unser Kundendienstteam.

Vérification de l'Installation

1. Alignement Vertical : Assurez-vous que l'arbre à chat est à la verticale.
2. Serrage : Serrez fermement toutes les pièces et vis, en particulier les parties supérieures contre le plafond.
3. Vérification des Accessoires : Vérifiez que tous les accessoires sont utilisés correctement.

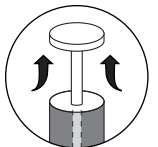

Utilisez la chaîne anti-basculement

Double sécurité : Fixez la chaîne anti-basculement incluse au mur pour éviter le basculement.

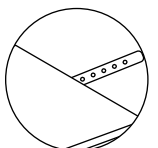

Avertissement de Risque de Basculement (faible probabilité & inévitable)

1. Placement : Gardez l'arbre à chat loin des objets de valeur comme les télévisions et les œuvres d'art.
2. Vérifications Régulières : Vérifiez fréquemment la stabilité et l'état de toutes les pièces.



Pour tout problème, contactez notre équipe de service client.

Controllo dell'Installazione

1. Allineamento Verticale: Assicurarsi che l'albero per gatti sia in posizione verticale.
2. Serraggio: Stringere saldamente tutte le parti e le viti, in particolare le parti superiori contro il soffitto.
3. Controllo degli Accessori: Verificare che tutti gli accessori siano utilizzati correttamente.

Utilizzare la catena anti-ribaltamento

Doppia sicurezza: Fissare la catena anti-ribaltamento inclusa alla parete per prevenire il ribaltamento.

Avvertenza sul Rischio di Ribaltamento (bassa probabilità & inevitabile)

1. Posizionamento: Tenere l'albero per gatti lontano da oggetti di valore come televisori e opere d'arte.
2. Controlli Regolari: Verificare frequentemente la stabilità e le condizioni di tutte le parti.

Per qualsiasi problema, contattare il nostro team di assistenza clienti.

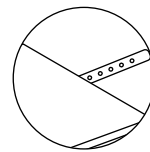
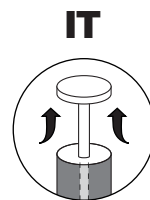

Verificación de la Instalación

1. Alineación Vertical: Asegúrese de que el árbol para gatos esté completamente vertical.
2. Apretado: Asegure todas las partes y tornillos firmemente, especialmente las partes superiores contra el techo.
3. Verificación de Accesorios: Verifique que todos los accesorios se utilicen correctamente.

Use la cadena anti-vuelco

Doble seguridad: Asegure la cadena anti-volcaduras incluida a la pared para evitar el vuelco.

Advertencia de Riesgo de Volcaduras (baja probabilidad & inevitable)

1. Colocación: Mantenga el árbol para gatos lejos de objetos de valor como televisores y obras de arte.
2. Revisiones Regulares: Verifique frecuentemente la estabilidad y el estado de todas las partes.

Para cualquier problema, contacte a nuestro equipo de servicio al cliente.

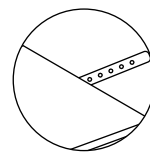
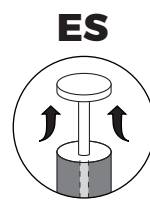

設置確認

1. 垂直整列: キャットツリーが完全に垂直に設置されていることを確認してください。
2. 締め付け: すべての部品とネジをしっかりと締めてください。特に上部の部品は天井にしっかりと押し付けてください。
3. アクセサリーの確認: すべてのアクセサリーが正しく使用されていることを確認してください。

転倒防止チェーンを使用してください

二重の安全性: 付属の転倒防止チェーンを壁に固定して、転倒を防ぎます。

転倒リスクの警告(小さい確率 & 避けられない)

1. 設置場所: キャットツリーをテレビや芸術作品などの貴重品から離して設置してください。
2. 定期的なチェック: 定期的にキャットツリーの安定性とすべての部品の状態を確認してください。

問題が発生した場合は、カスタマーサービスチームにご連絡ください。

