

ARTERIOS

FLETCHER DINING CHAIR

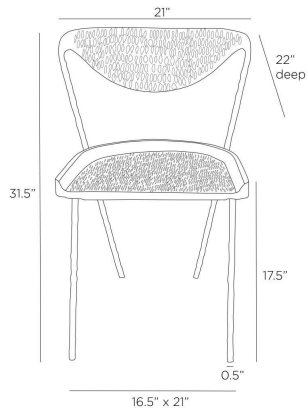

FRI23

H: 31.5 IN, W: 21 IN, D: 22 IN,

Ebony

Designed to hug the body, a contemporary modern chair possesses a curved integrated metal back inspired by a suspension bridge. The recessed seat of ebony mango wood is paired with angled legs of blackened iron, delivering a look of lightness and ease belied by this style's substantial base.

APPEARANCE

Material	Wood, Iron
Material Type	Mango
Finish	Ebony, Blackened Iron
Top Coat/Sealant	Yes

DIMENSIONS

Arm	H: 30 IN, W: 0.5 IN, D: 5 IN
Foot Print	W: 16.5 IN, D: 21 IN
Leg	Dia: 0.50 IN
Seat	H: 18 IN, W: 19.5 IN, D: 19 IN
Seat Back	H: 14 IN, W: 20 IN, D: 0.5 IN
Diagonal Dimension	38.5 IN
Clearance	17.5 IN

SHIPPING

Product Weight	28 lbs
Gross Weight 1	40 lbs
Shipping Box 1	H: 36.5 IN, L: 23 IN, W: 27.5 IN

ADDITIONAL INFO

Leg Or Foot Application	Vinyl Caps
-------------------------	------------

CONTRACT

Contract Suitable	Not for use in high traffic/public spaces
-------------------	---