

Assembly Instructions

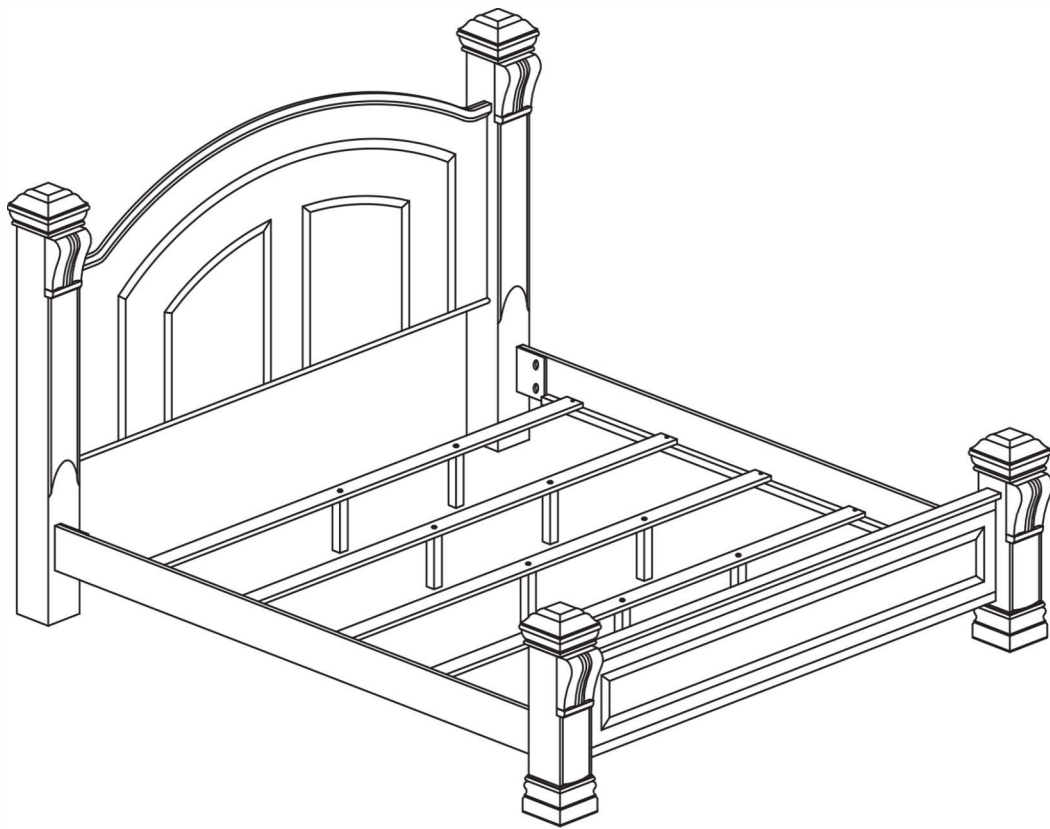

ASSEMBLY RATING

The Assembly Rating is a 5-point system that shows the degree of effort needed in assembling a specific product (with 1 being easy and 5 being difficult). For some products, two persons are recommended.

EASY



DIFFICULT

Tools Required For Assembly:

Allen Wrench



(Included)

Wrench



(Included)

Phillips Screwdriver



(Not Included)



2 PERSONS RECOMMENDED

ASSEMBLY & CARE ADVICE

FOR YOUR FURNITURE TO LAST, CORRECT ASSEMBLY AND PROPER MAINTENANCE ARE NECESSARY. PLEASE FOLLOW THE INFORMATION PROVIDED BELOW TO FULLY ENJOY YOUR FURNITURE.

BASIC ASSEMBLY TECHNIQUES

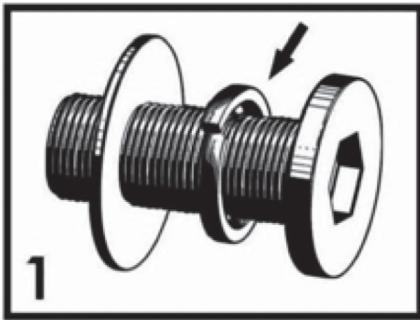

When lock or spring washer is used in an assembly, please make sure the lock or spring washer is placed between the larger flat washer and the head of the screw or bolt.



Position each part correctly and insert screws or bolts into their respective holes by hand tighten or using the proper hand tool. Only tighten when step is completed or when instructed to do so.



Use cardboard or carpet area when assembling furniture to prevent scratches. Make sure the furniture rests on a flat and level surface with each leg evenly touching the floor.

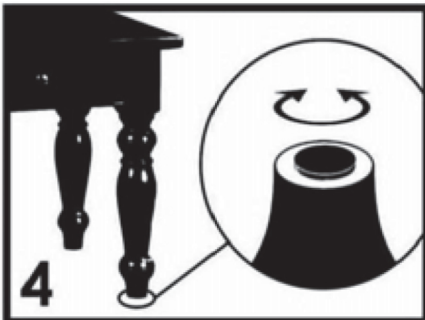

Some furniture comes with height adjustment knobs underneath each leg. To lower or to raise each leg, you need to turn clockwise or counterclockwise, respectively.

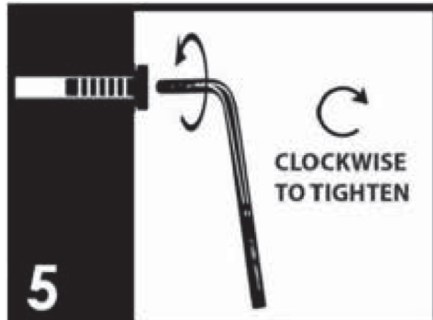

Make sure all parts are properly aligned, then use the appropriate hand tool to completely tighten the bolts or screws. Do not use power tools and do not overtighten.



Save the instructions and store the Allen wrench or any supplied tool for later maintenance. After two weeks, check and tighten any loose hardware and repeat again every six months thereafter.

IT IS THE USER'S RESPONSIBILITY TO MAINTAIN THE FURNITURE. THE HARDWARE MAY LOOSEN OVER TIME AND MAY CAUSE THE FURNITURE TO BE WOBBLY AND UNABLE TO SUPPORT ITS INTENDED WEIGHT CAPACITY. THIS MAY LEAD TO COLLAPSE AND MAY CAUSE SERIOUS INJURY.











FAILURE TO FOLLOW THE GUIDELINES ABOVE MAY RESULT IN INJURY AND/OR PROPERTY DAMAGE.



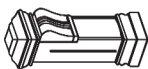







Before you begin, please read Page 2 of "Assembly and Care Advice".

And remember, do not tighten until each step is completed or instructed.

Parts List

	#1 x 1pc Headboard
	#2 x 2pcs Headboard leg (L-R)
	#3 x 1pc Footboard
	#4 x 2pcs Footboard leg (L-R)
	#5 x 2pcs Side Rail
	#6 x 4pcs Slat
	#7 x 8pcs Support Leg
	#J x 1pc Wrench
	#K x 8pcs Screw

Hardware List

	#A x 12pcs Bolt 5/16" X 1-3/4"
	#B x 12pcs Lock Washer
	#C x 12pcs Flat Washer
	#D x 1pc Allen Wrench
	#E x 8pcs Thread Bolt
	#F x 8pcs Nylon Washer
	#G x 8pcs Flat Washer
	#H x 8pcs Lock Washer
	#I x 8pcs Hex Nut



#A X 6PCS
 #B X 6PCS
 #C X 6PCS

Note: Left and right is determined by facing the front of the head-board.

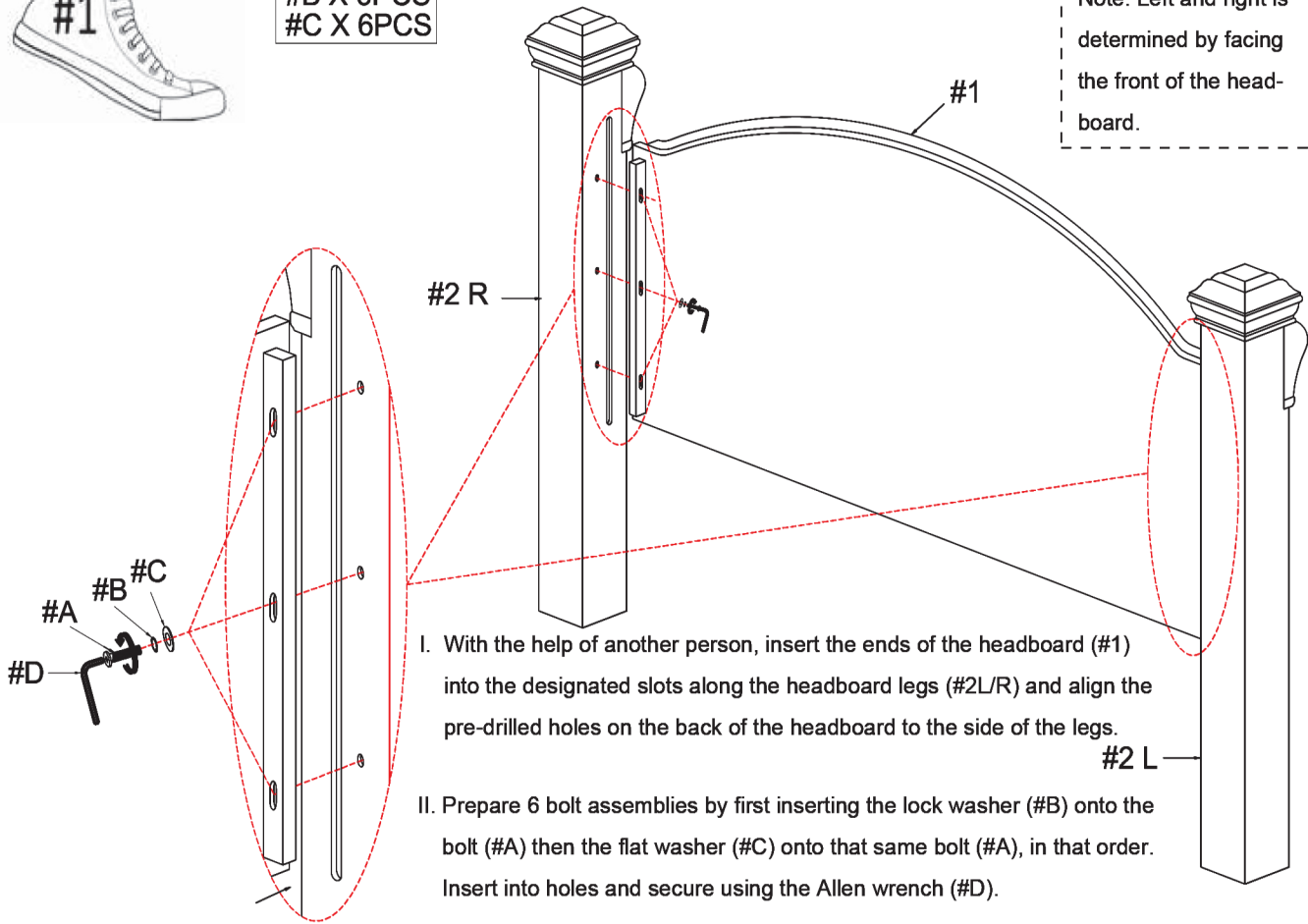

#A X 6PCS
 #B X 6PCS
 #C X 6PCS

Note: Left and right is determined by facing the front of the foot-board.

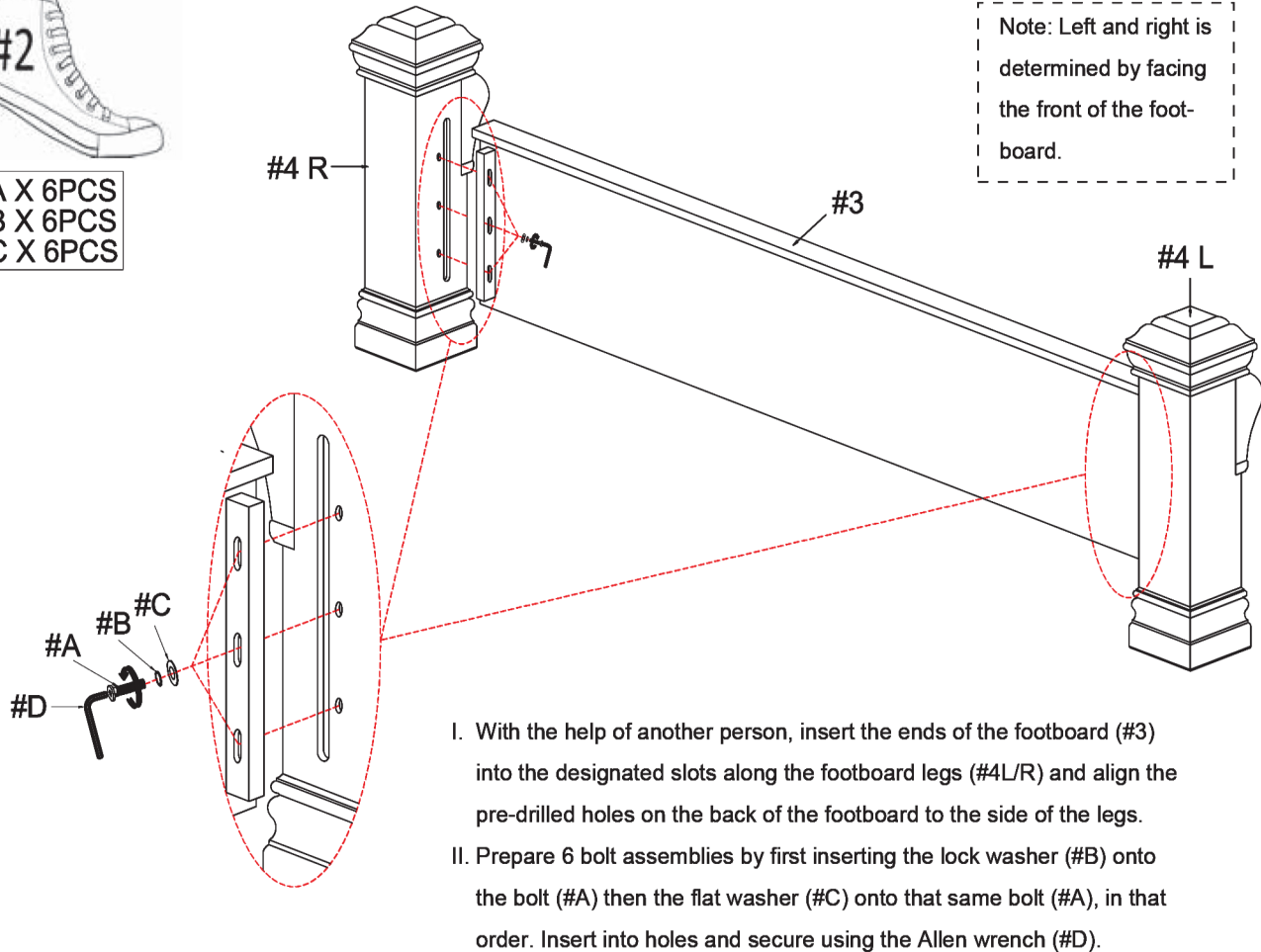



#E X 8PCS
#F X 8PCS
#G X 8PCS
#H X 8PCS
#I X 8PCS

1. Insert 2 bolts (#E) along each side of the headboard (#1) and footboard (#3), turn right to tighten. Then apply the side rails (#5) onto the other ends of those bolts (#E).

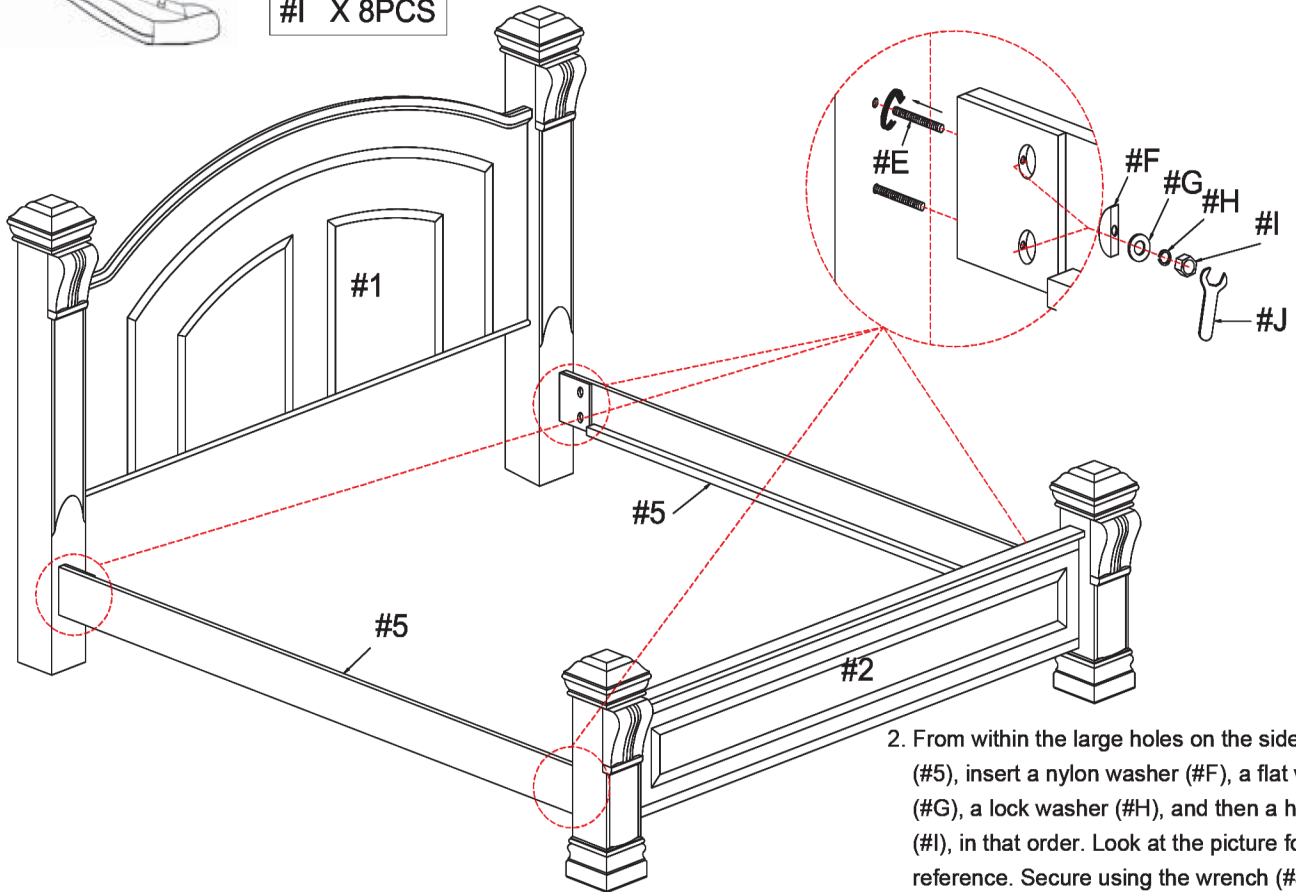

2. From within the large holes on the side rails (#5), insert a nylon washer (#F), a flat washer (#G), a lock washer (#H), and then a hex nut (#I), in that order. Look at the picture for reference. Secure using the wrench (#J).



Insert the threaded ends of the support legs (#7) into the pre-drilled holes located on the bottom of the slats (#6). Turn right to tighten.

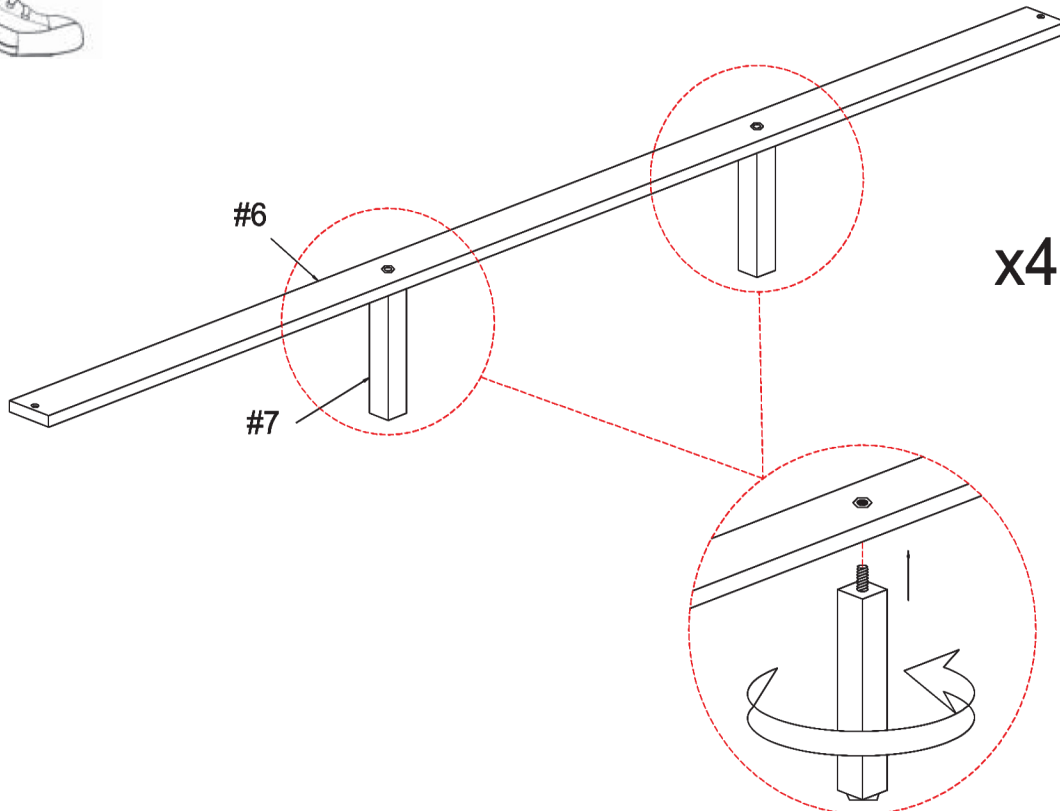



#E X 8PCS

Align the ends of the slats (#6) to the pre-drilled holes along the sides of the side rails (#5). Insert a screw (#K) into each end and secure using a Phillips screwdriver.

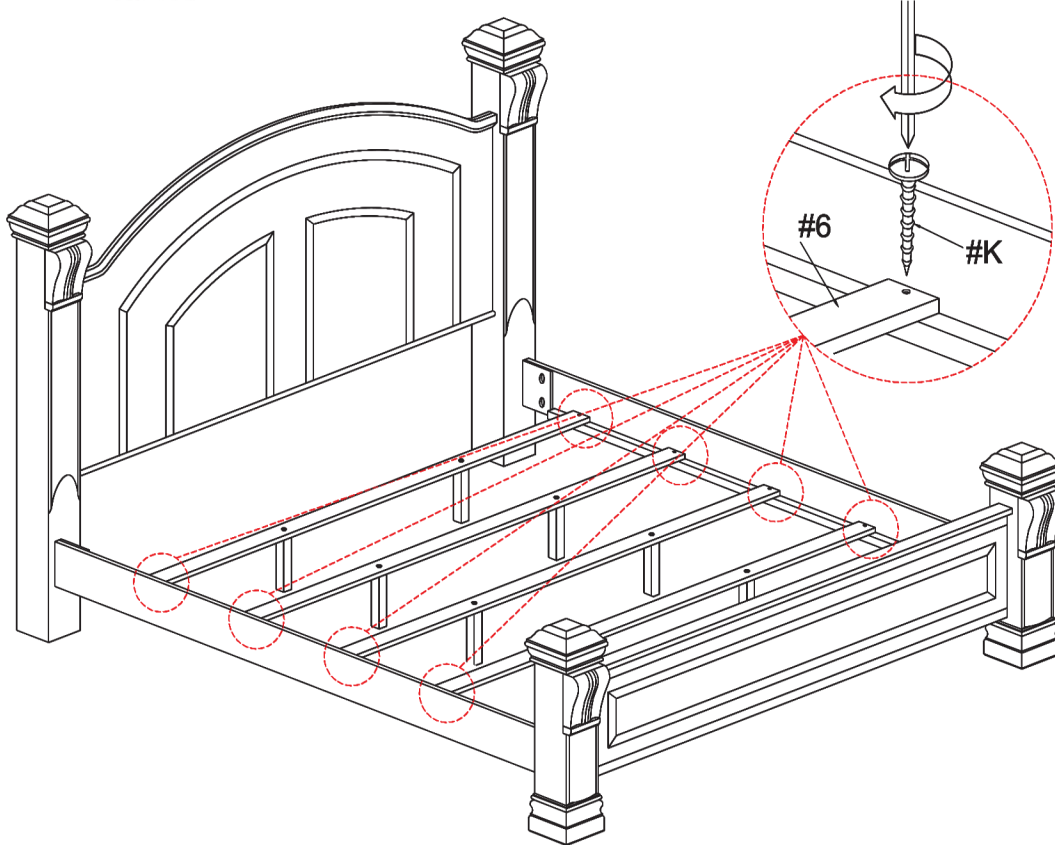

Make sure all parts are firmly secured.

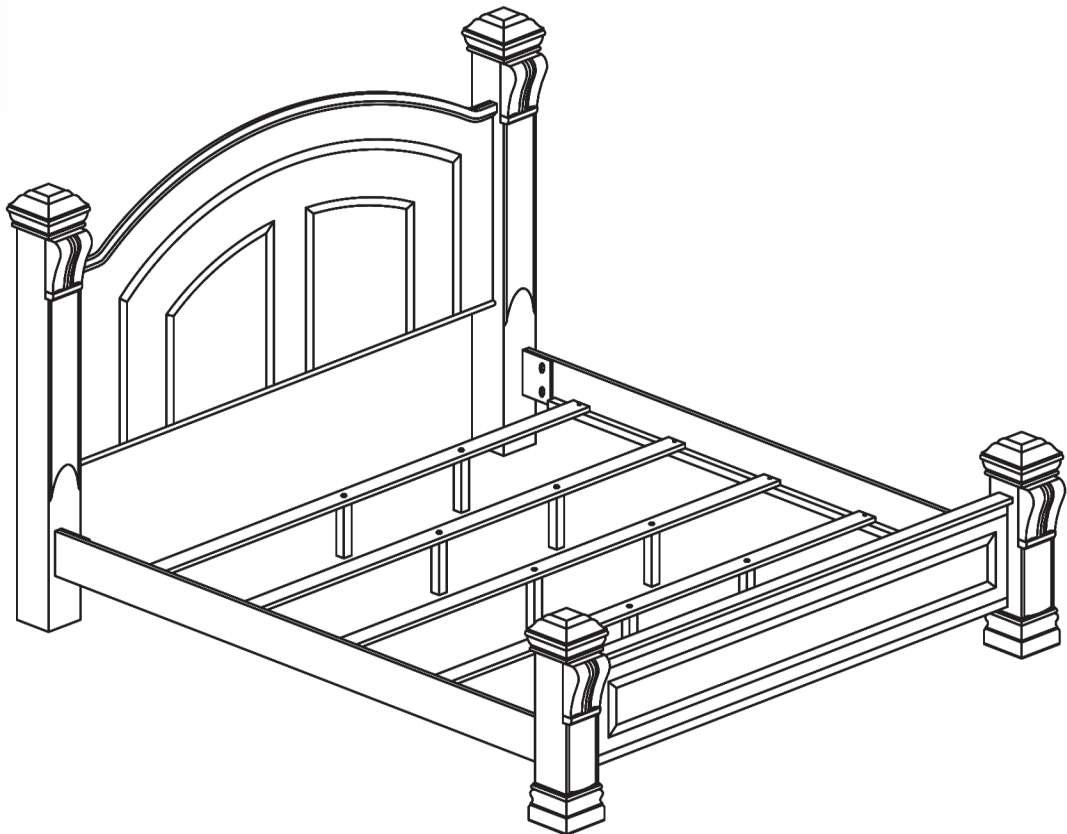

ASSEMBLY IS COMPLETED