

INSTRUCTION MANUAL

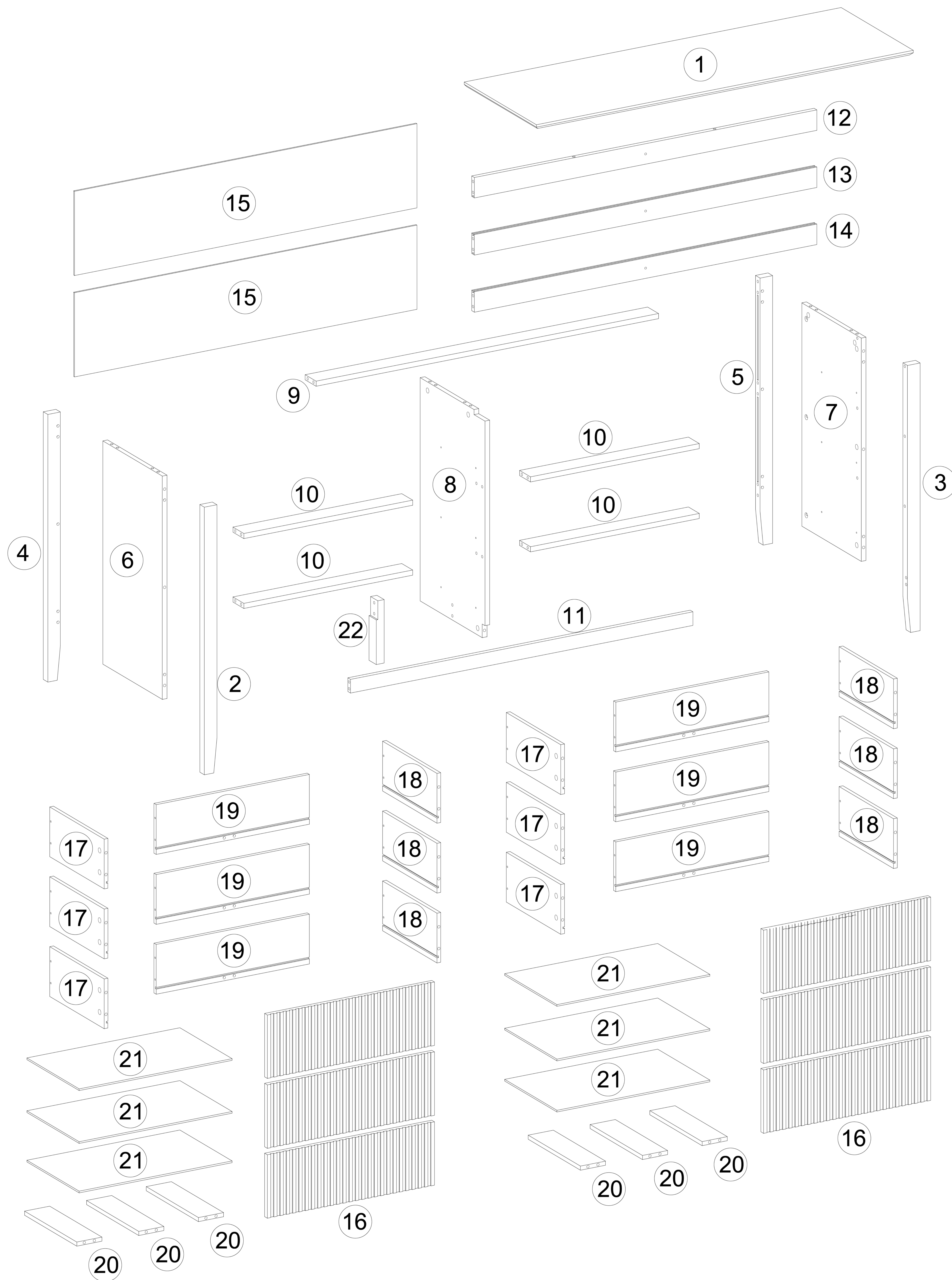

MAINTENANCE AND CARE

Clean regularly using a soft brush or vacuum with a brush attachment. Avoid harsh chemicals or abrasive cleaners.

Wash with a hose or pressure washer on a low-pressure setting for heavy soiling. Rinse thoroughly afterward.

Ensure proper drying after cleaning or exposure to rain to prevent mold or mildew growth.

Protect from extreme weather by moving furniture to a covered area or using furniture covers or tarps.

Avoid dragging or placing heavy objects on the furniture to prevent damage.

Apply UV protection spray or furniture wax to prevent fading and damage from the sun.

Regularly inspect for wear, loose strands, or damage and address issues promptly.

WARRANTY INFORMATION

Warranty Coverage: Our warranty provides protection against manufacturing defects in materials and workmanship for a specified period from the date of purchase, as outlined in the accompanying warranty documentation.

Exclusions: The warranty does not cover damages resulting from misuse, negligence, accidents, normal wear and tear, unauthorized repairs or modifications, improper assembly, or failure to adhere to the care and maintenance guidelines provided.

Warranty Claim Process

To initiate a return on Amazon, please follow these steps:

- 1 Log into your Amazon account and go to the "Your Orders" section.
- 2 Locate the order containing the item you wish to return.
- 3 Contact our customer service for assistance in obtaining a prepaid return label.
- 4 Once you receive the return label, securely affix it to the package.
- 5 You can then choose to drop off the package at a designated carrier location or arrange for a pickup.
- 6 After we receive and inspect the returned product, we will initiate the refund process.
- 7 The refund will be credited back to the original payment method used during the purchase.
- 8 Typically, refunds are processed within 3-5 business days.

STEP 19

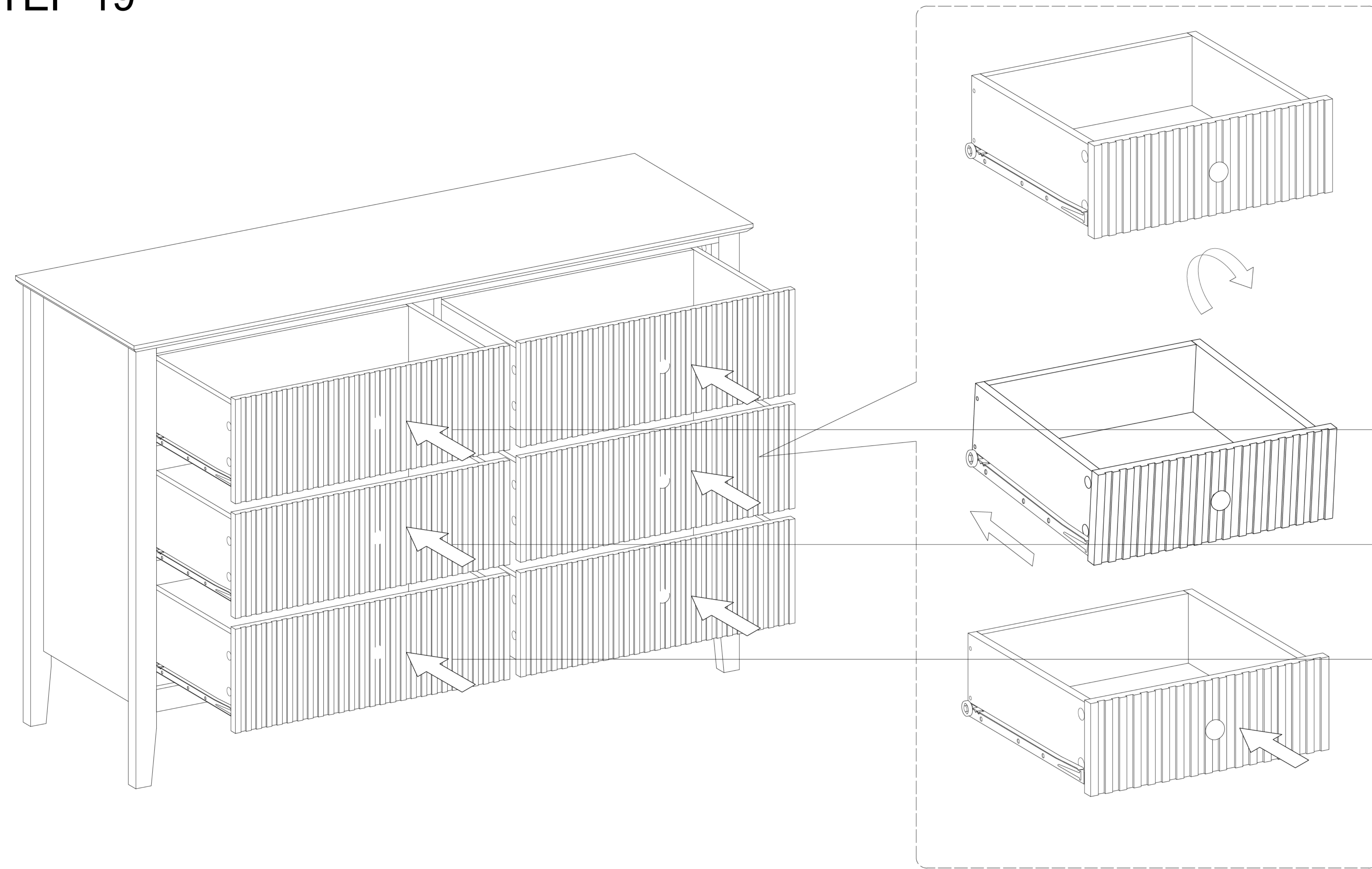

STEP 20

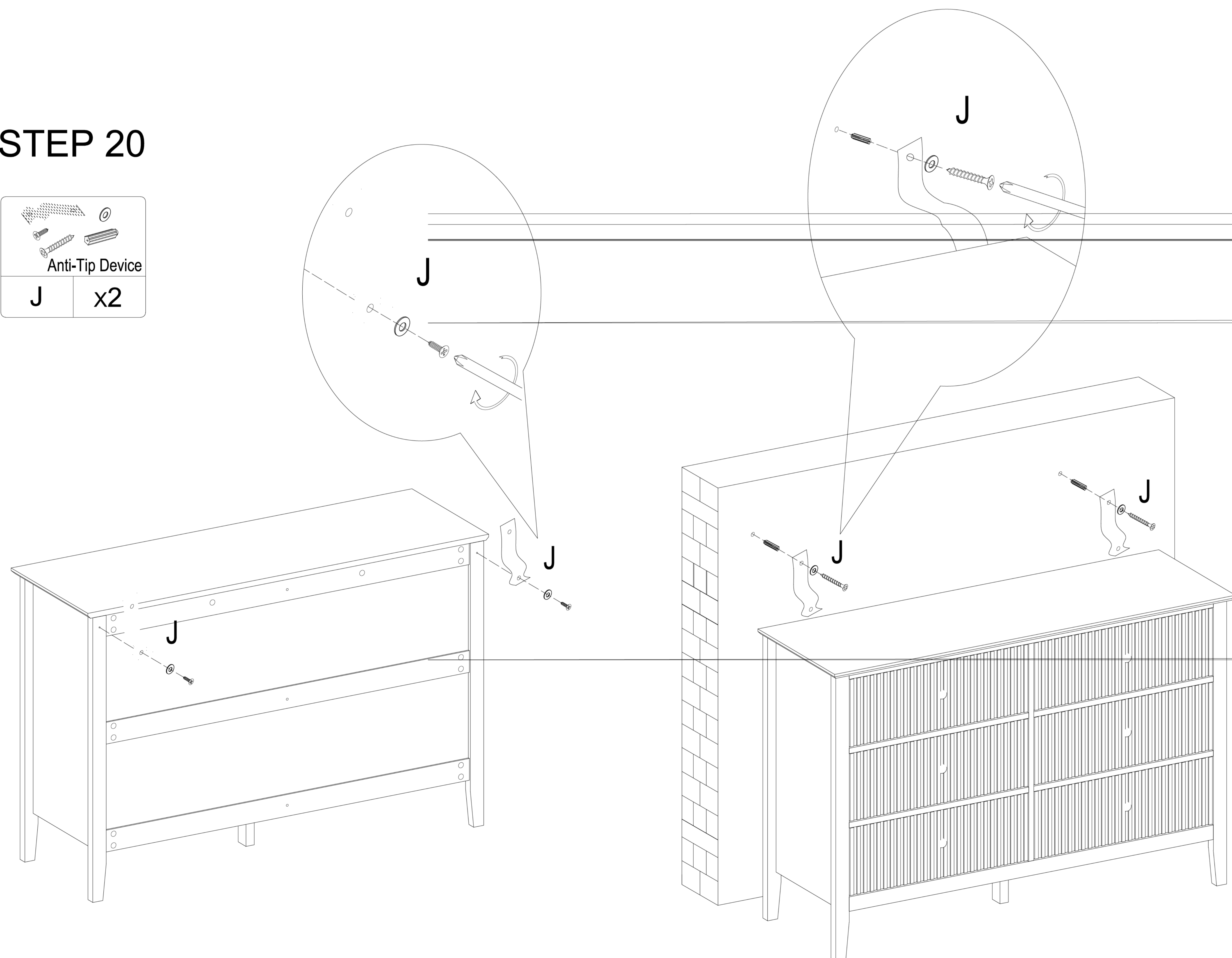
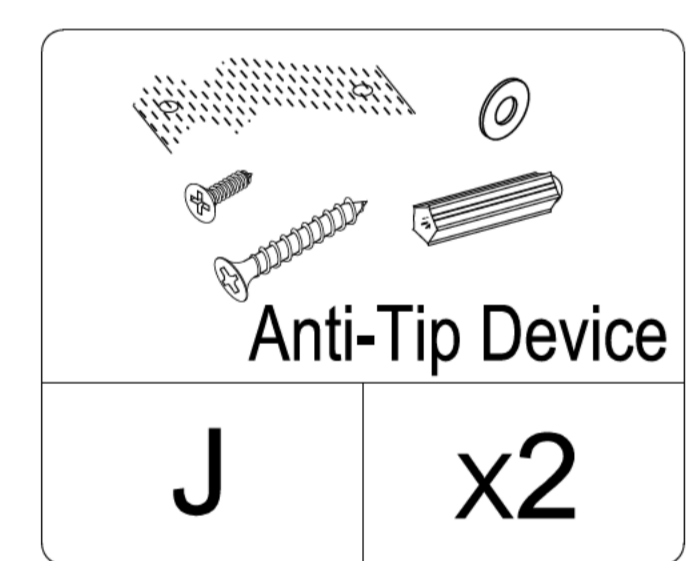

Carefully unpack all the components and verify that all the necessary parts are included as listed in the packaging.

Identify each component and refer to the provided assembly diagram or step-by-step instructions. Assemble the furniture in the order specified to ensure proper alignment and fit.

Use the provided tools or recommended tools for assembly. Do not use excessive force when tightening screws or bolts.

If any difficulties arise during assembly, consult the troubleshooting section or contact our customer support.

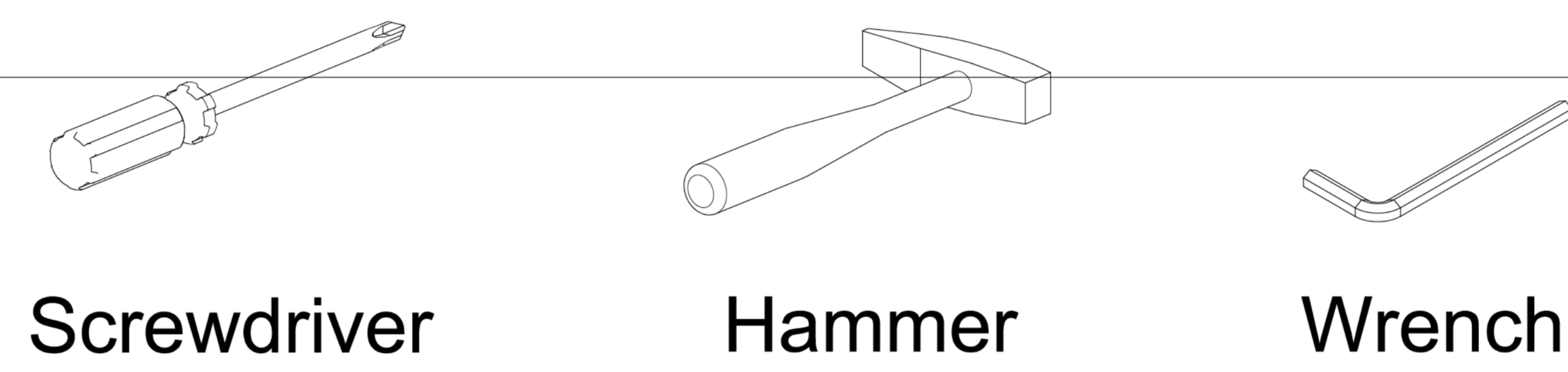

Tools Required



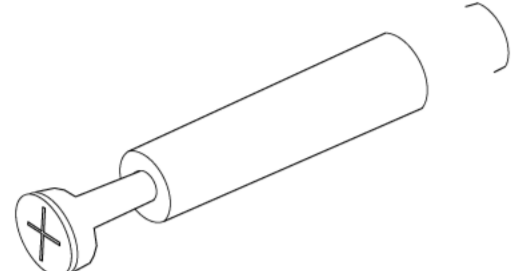
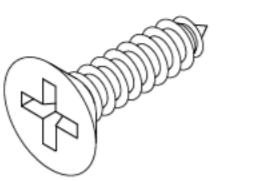
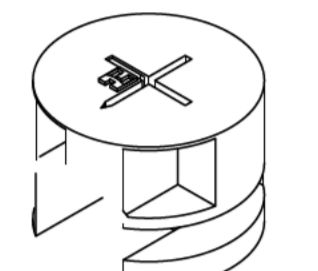
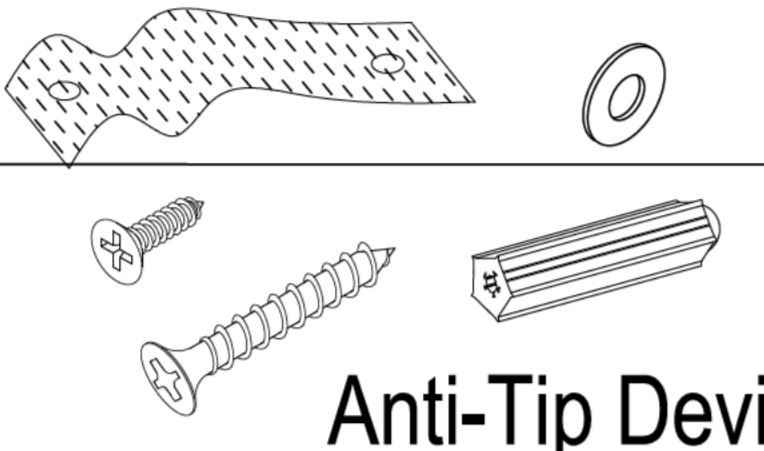
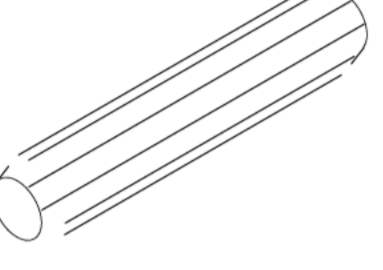
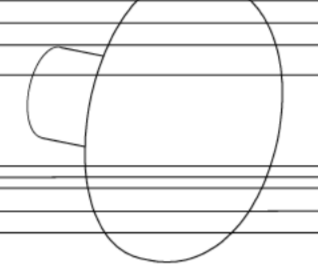
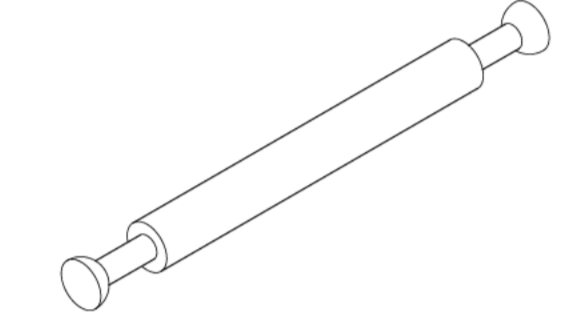
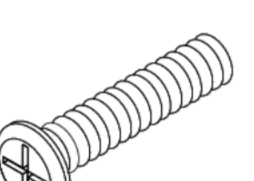
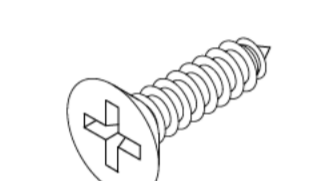

Board parts List

NO.	PICTURE	QTY	NO.	PICTURE	QTY	NO.	PICTURE	QTY
1	Front Panel	1	8	Middle Side Panel	1	15	Back Panel	2
2	Left Front Leg	1	9	Front Upper Crossbar	1	16	Drawer Front Panel	6
3	Right Front Leg	1	10	Front Middle Crossbar	4	17	Drawer Left Side	6
4	Left Rear Leg	1	11	Front Lower Crossbar	1	18	Drawer Right Side	6
5	Right Rear Leg	1	12	Upper Rear Support Bar	1	19	Drawer Back Panel	6
6	Left Side Panel	1	13	Middle Rear Support Bar	1	20	Support Bar	6
7	Right Side Panel	1	14	Lower Rear Support Bar	1	21	Drawer Bottom Panel	6
						22	Middle Leg	1

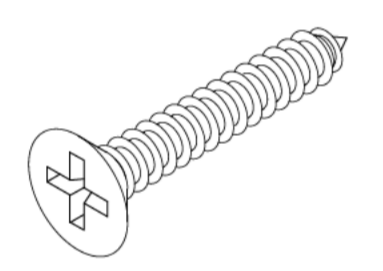
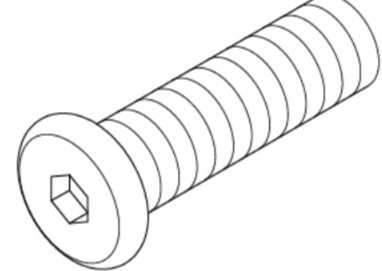
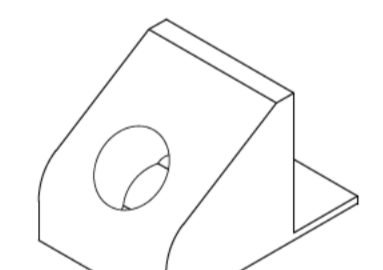
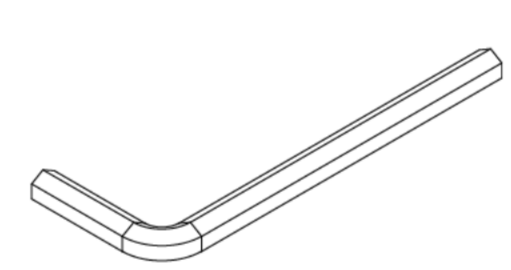
Hardware parts List

NO.	PICTURE	QTY	NO.	PICTURE	QTY
A	 2-in-1 Bolt	95+3	H	 Self-Tapping Screw 3x16mm	12+1
B	 Cam Lock 15x10mm	103+3	J	 Anti-Tip Device	2
C	 Wooden Dowel	16+1	K	 Handle	6
D	 Double-Ended 2-In-1 Screw	4+1	L	 Handle Bolt	6+1
E	 Self-Tapping Screw 3.5x12mm	72+3	M	 Screw Hole Cover	103+3
F	 Self-Tapping Screw 3.5x30mm	27+2	N	 Hex Socket Screw	2+1
G	 Back Panel Clamp	12+1	P	 Wrench	1

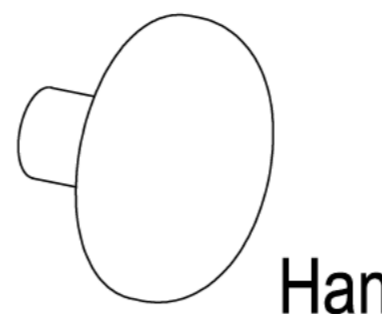
STEP 17

	Handle		Handle Bolt
K	x6	L	x6

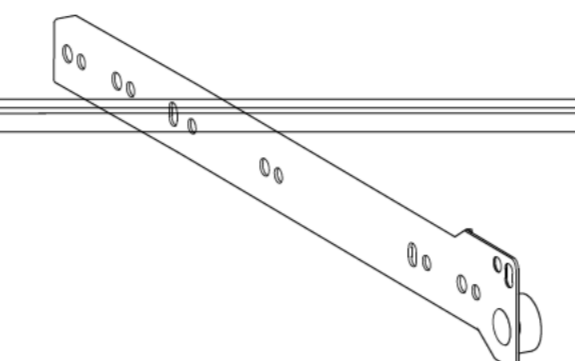
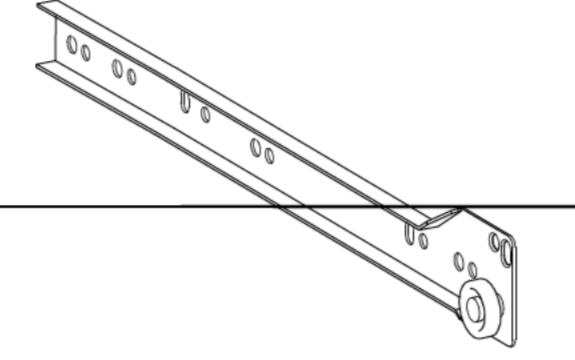
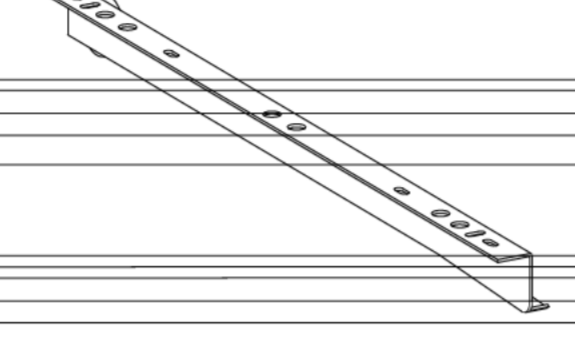
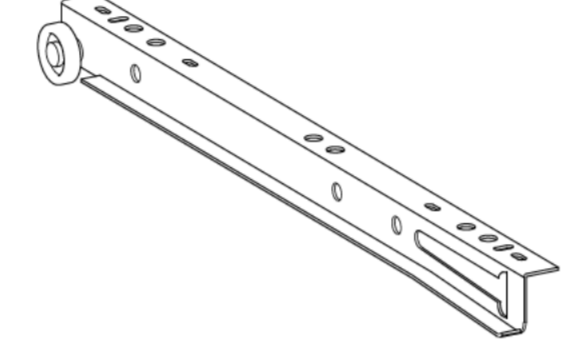
NO.	PICTURE	QTY
CL	 L=300mm Left Drawer Slide	6
CR	 L=300mm Right Drawer Slide	6
DL	 L=300mm Left Drawer Slide	6
DR	 L=300mm Right Drawer Slide	6

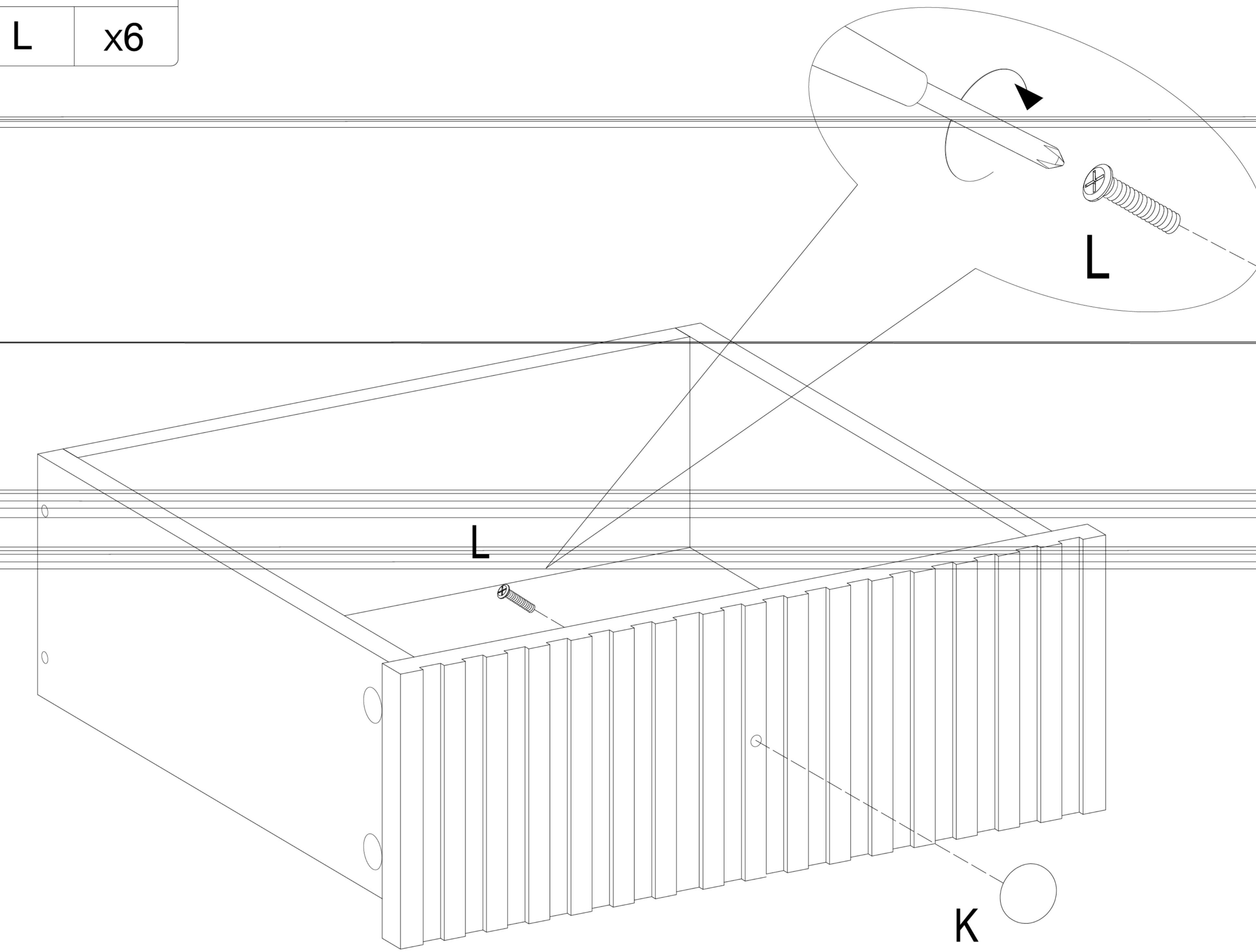

STEP 18

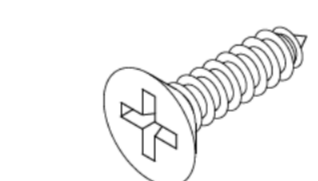
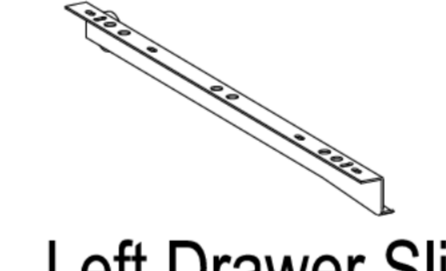
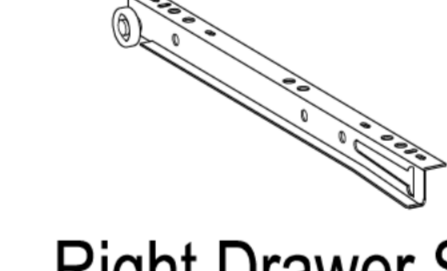
	Self-Tapping Screw 3.5x12mm		Left Drawer Slide		Right Drawer Slide
E	x36	DL	x6	DR	x6

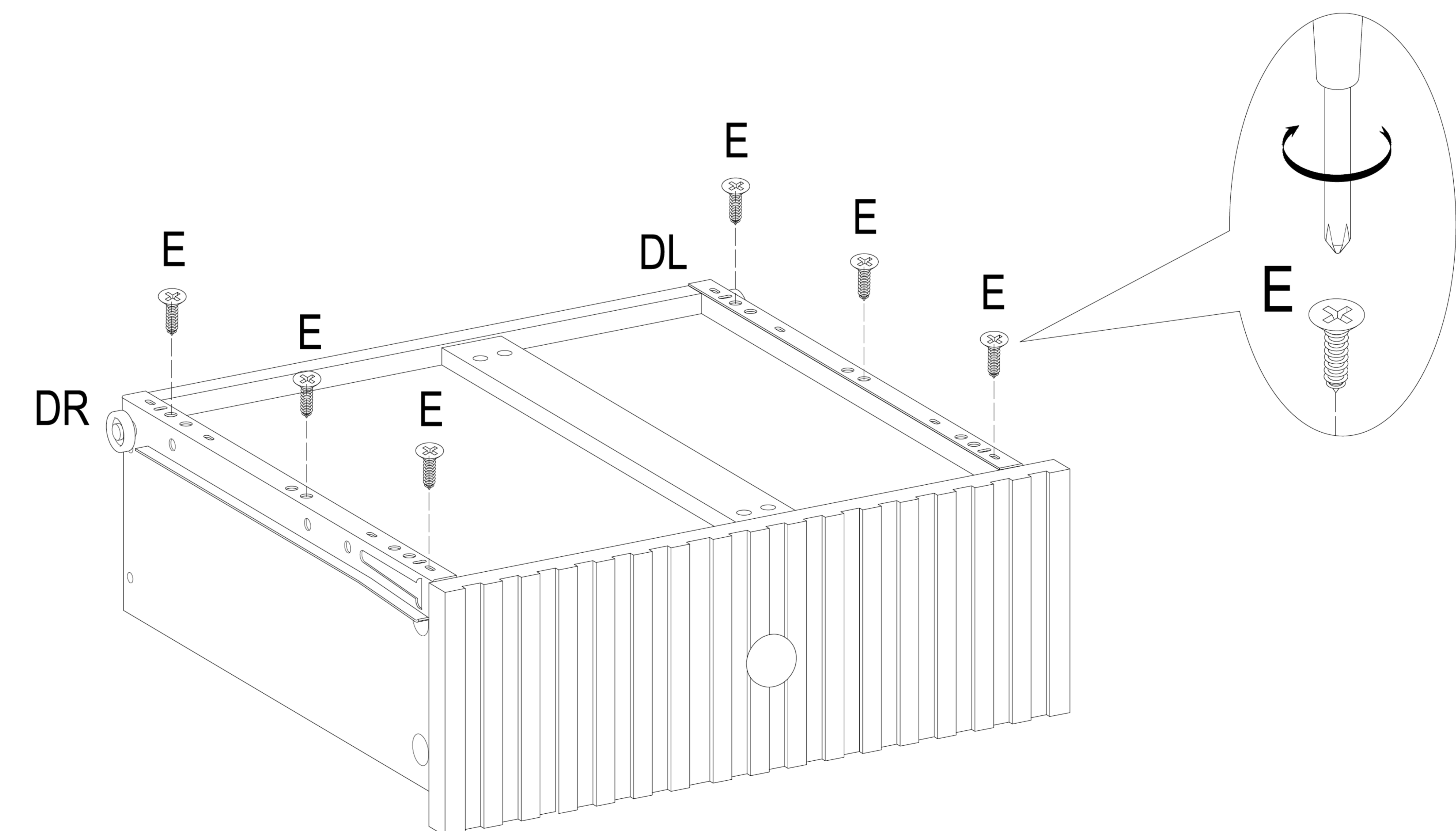
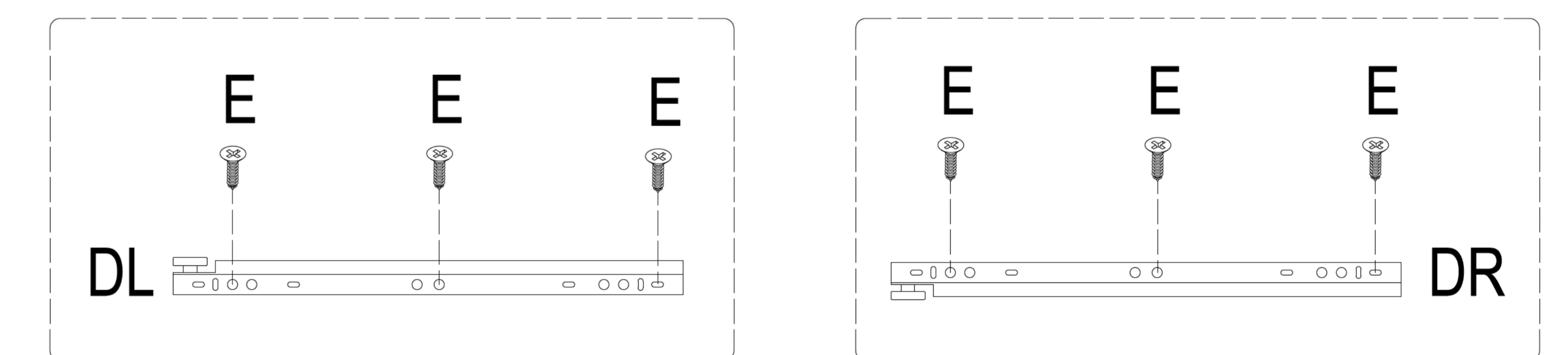

STEP 15

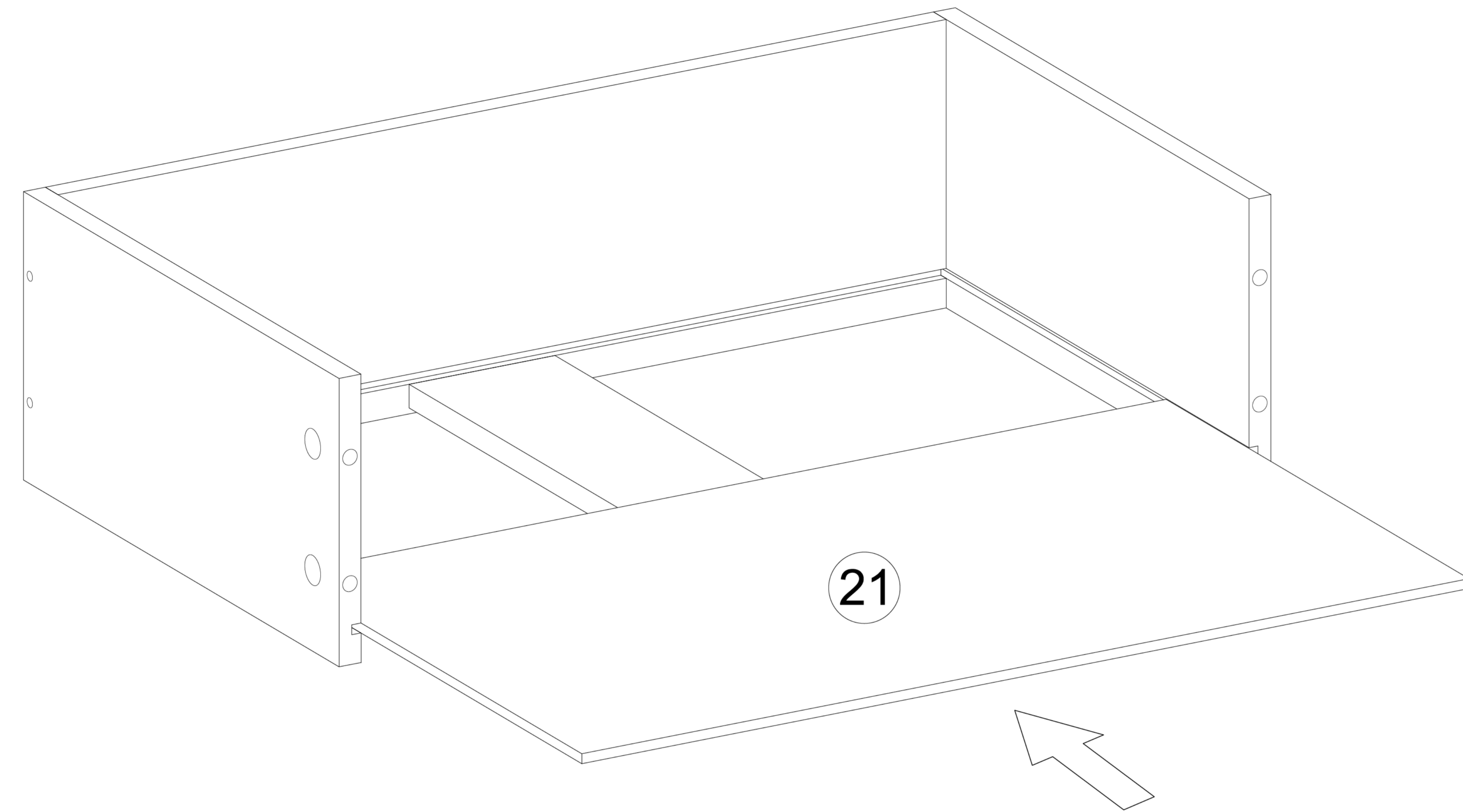
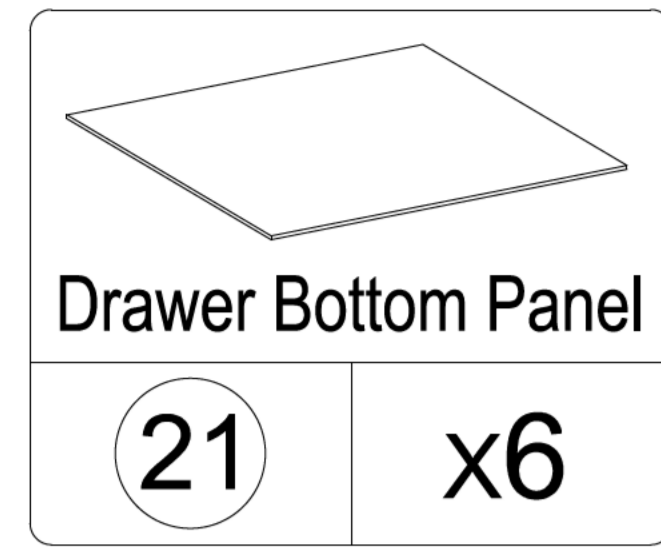

STEP 16

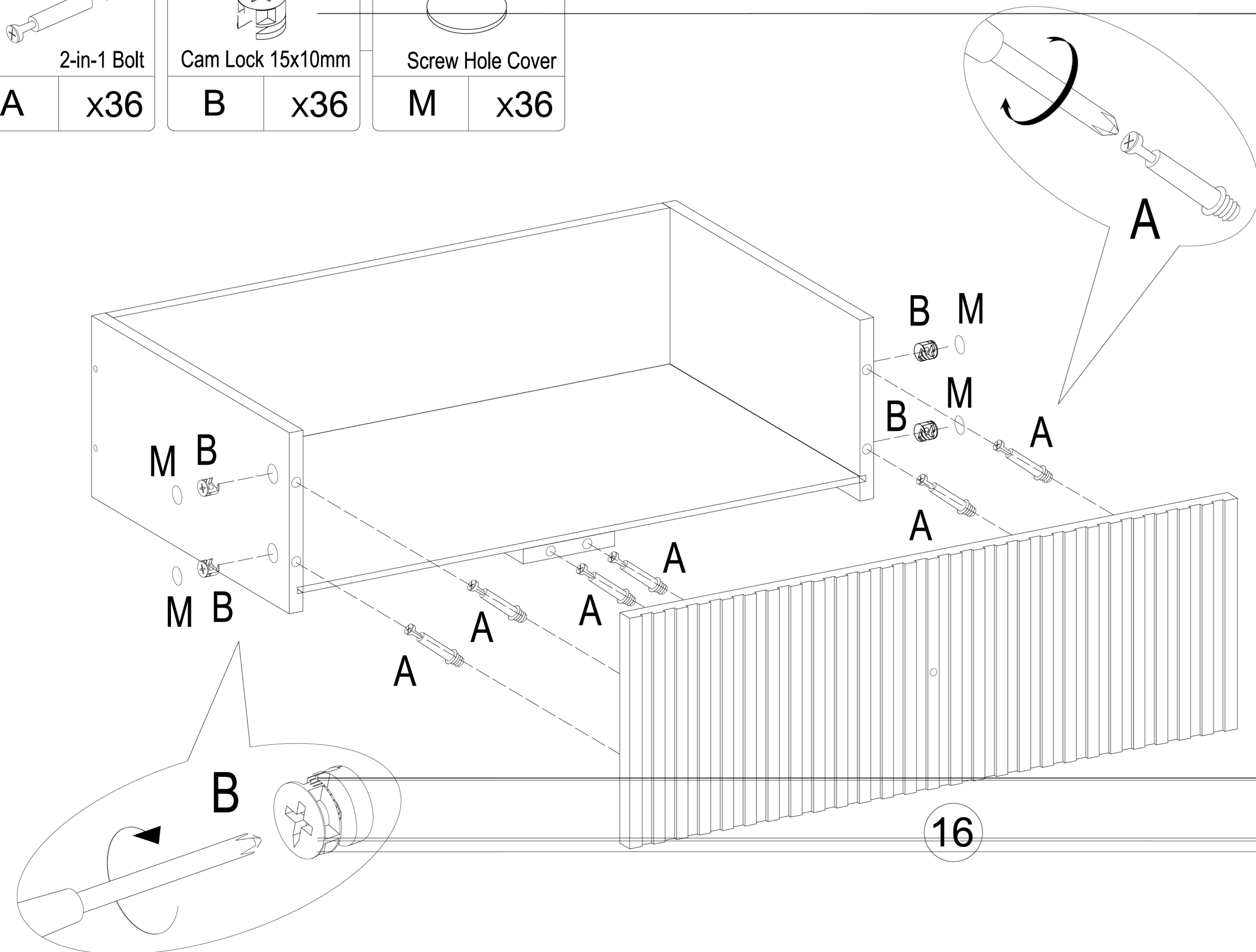
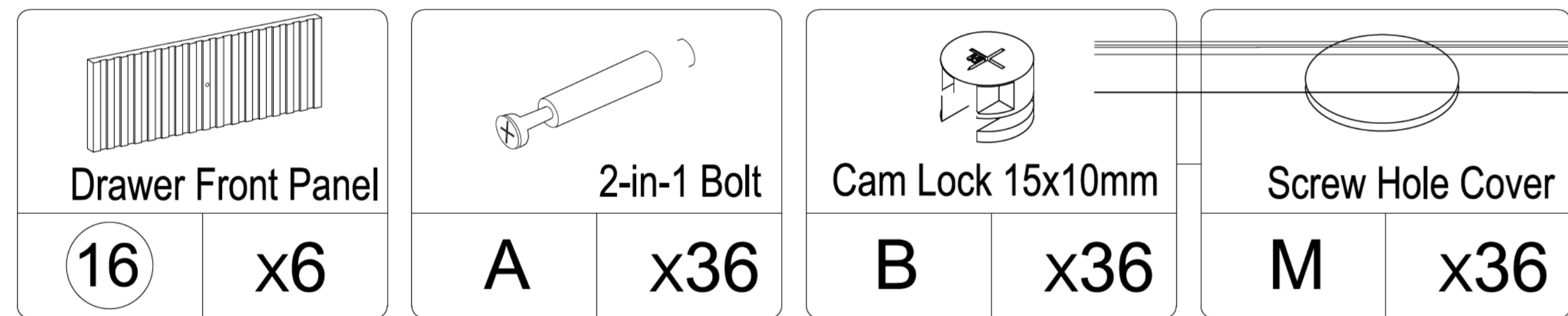

STEP 1

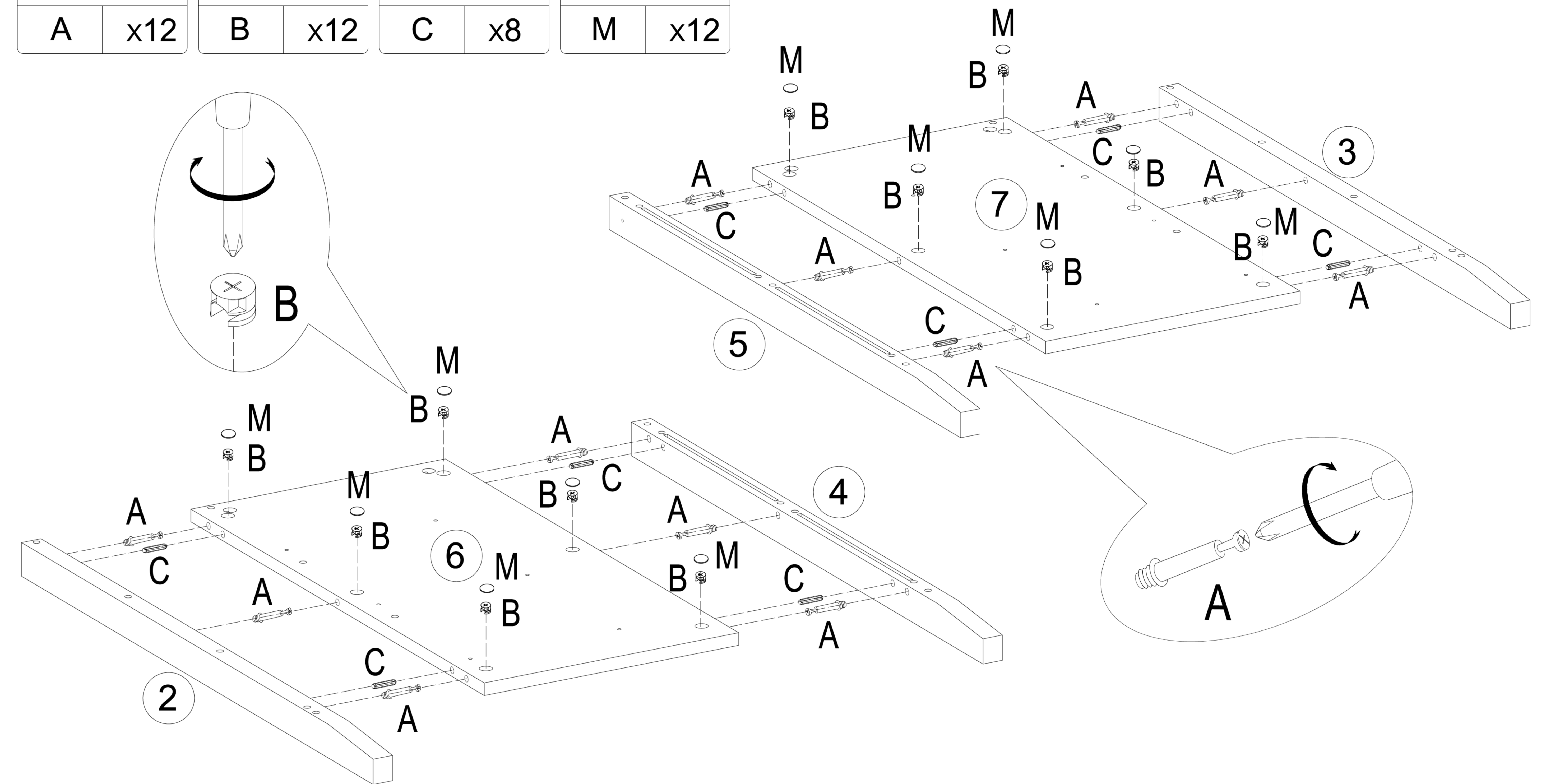
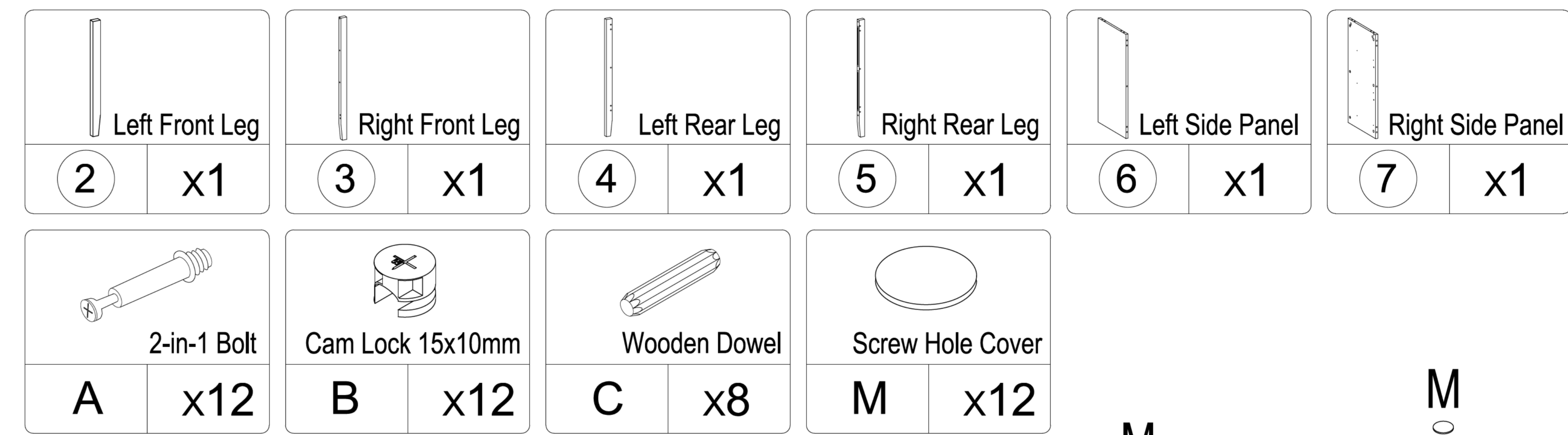

STEP 2

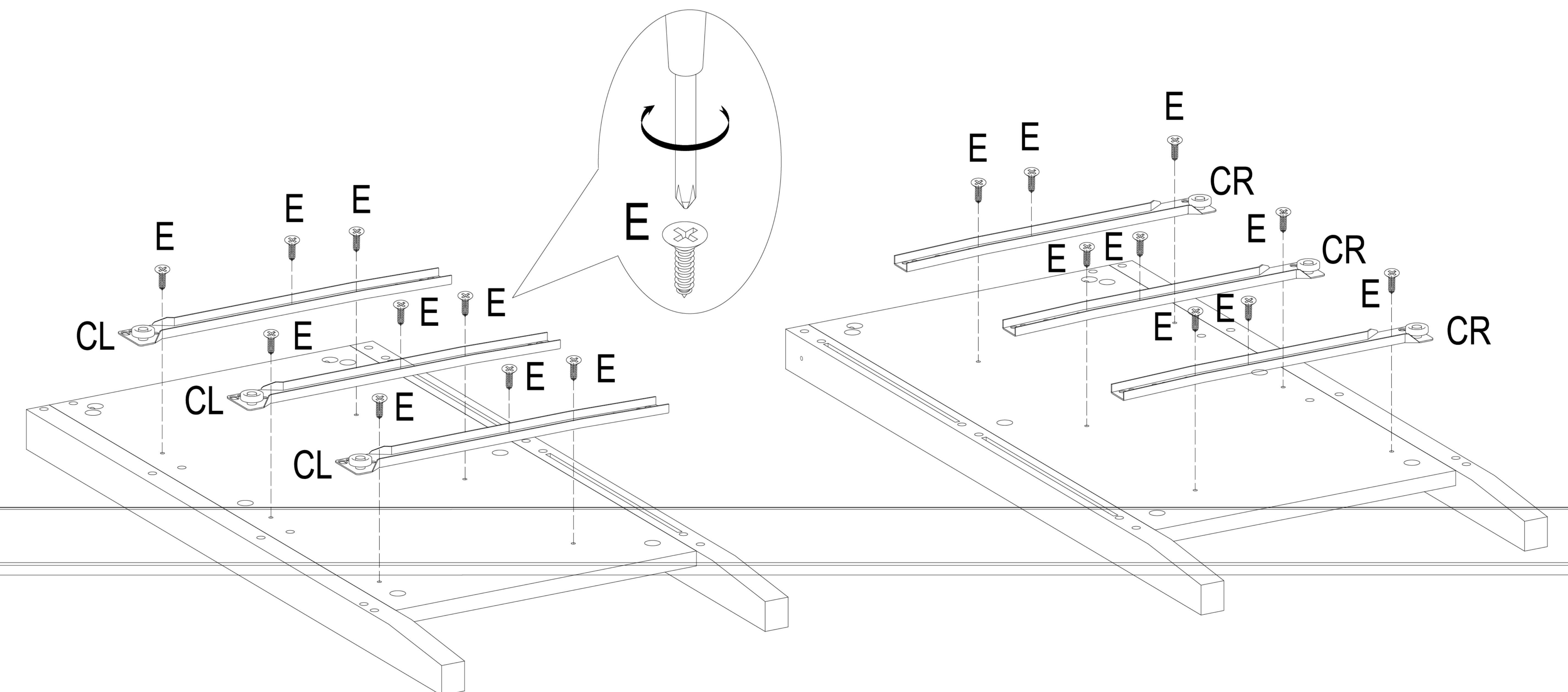
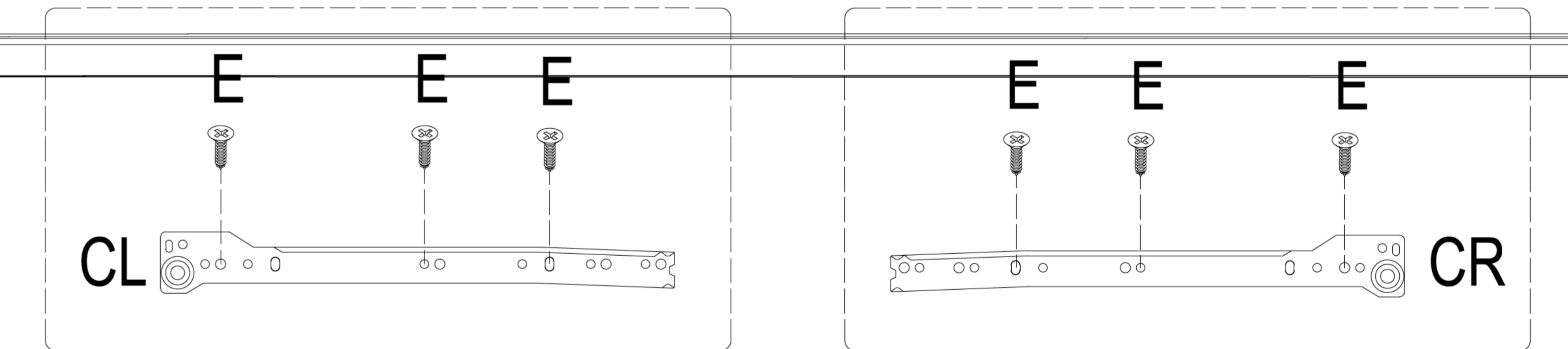
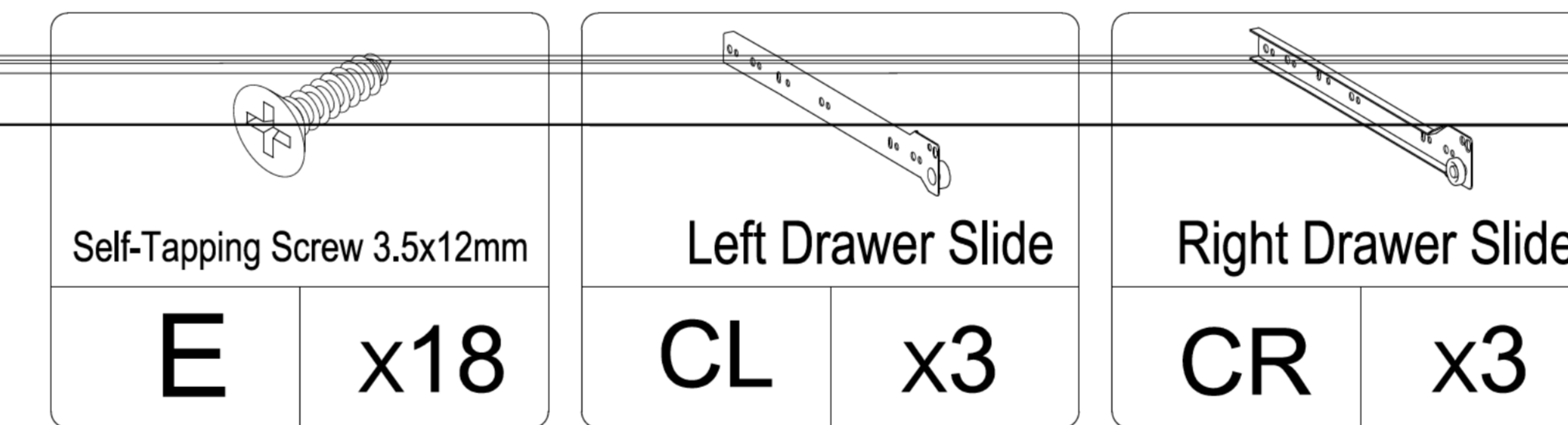

STEP 3

8 x1	E x18	CL x3	CR x3

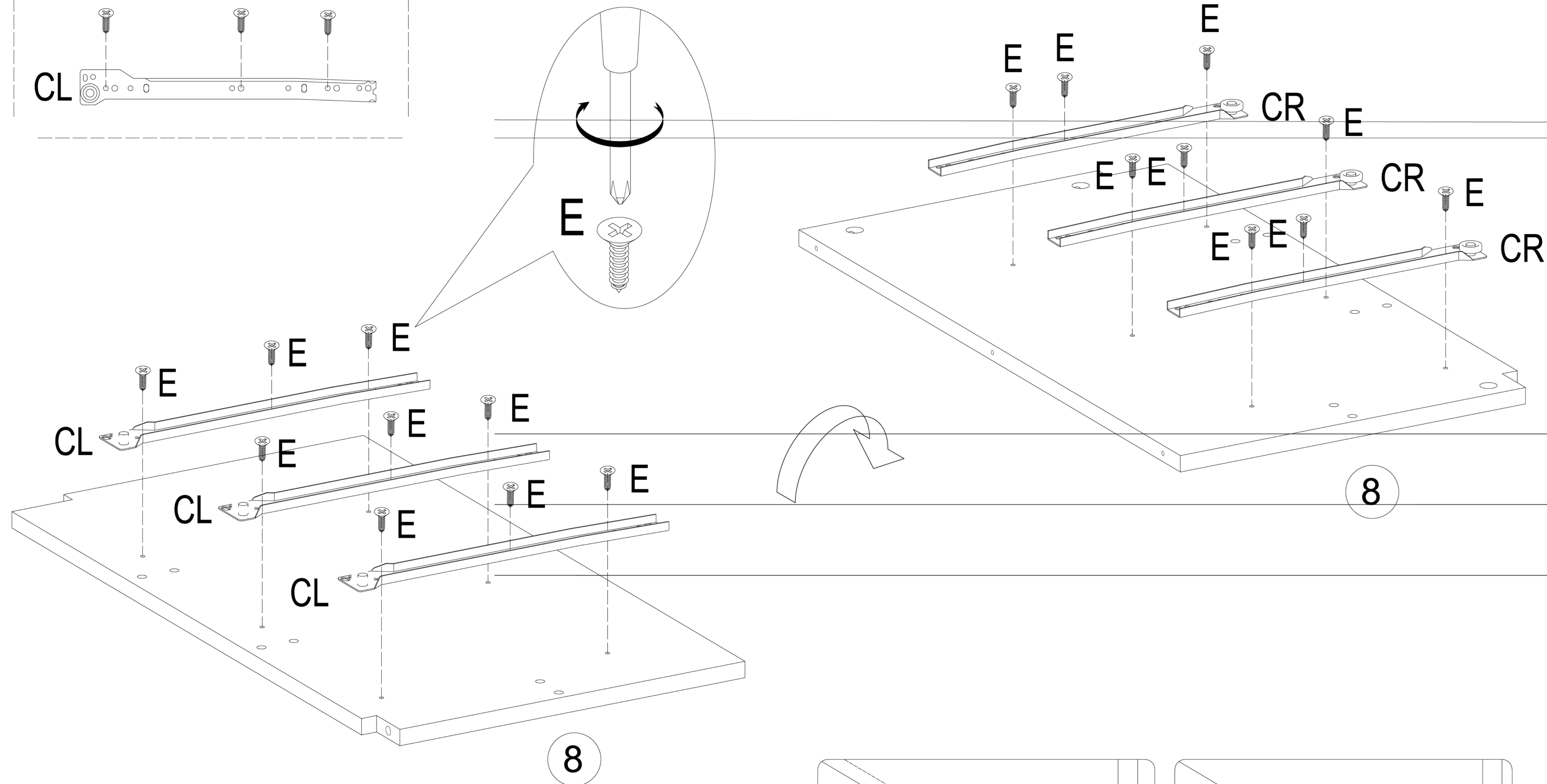
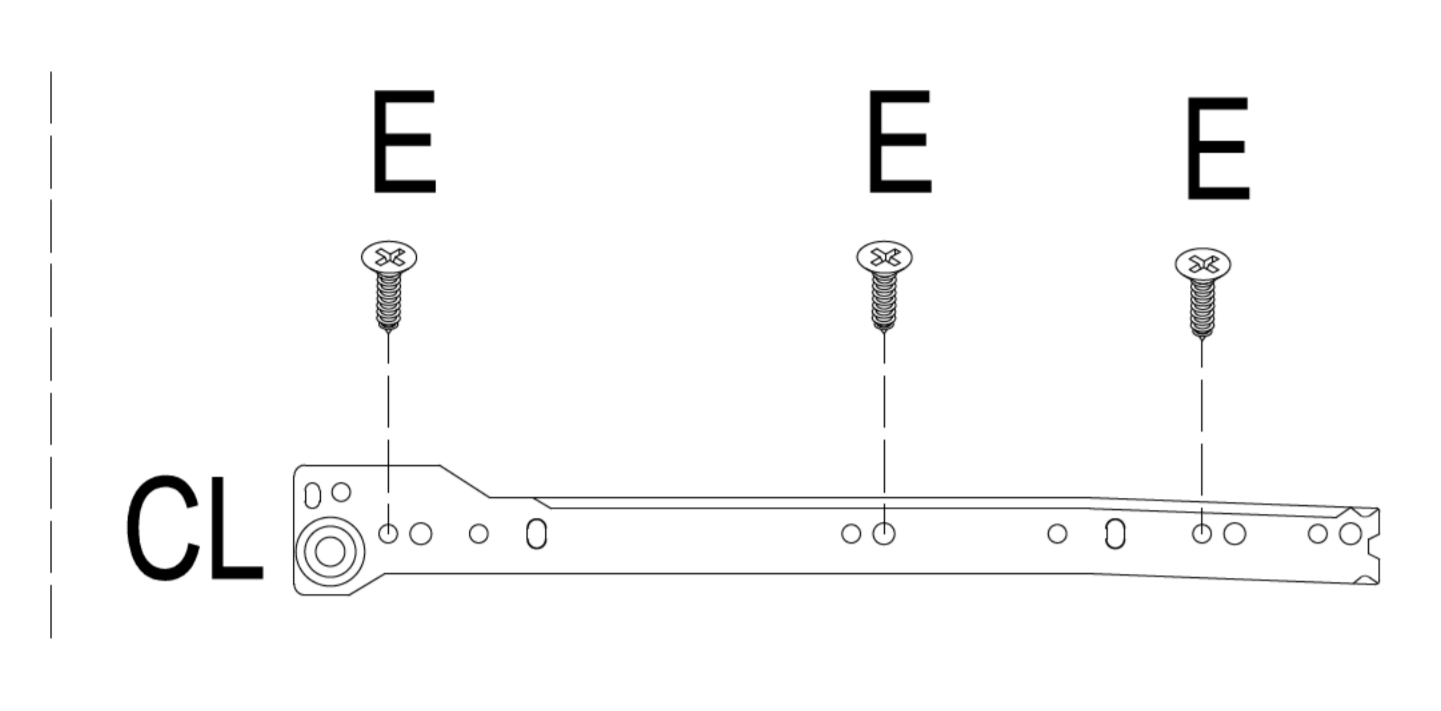
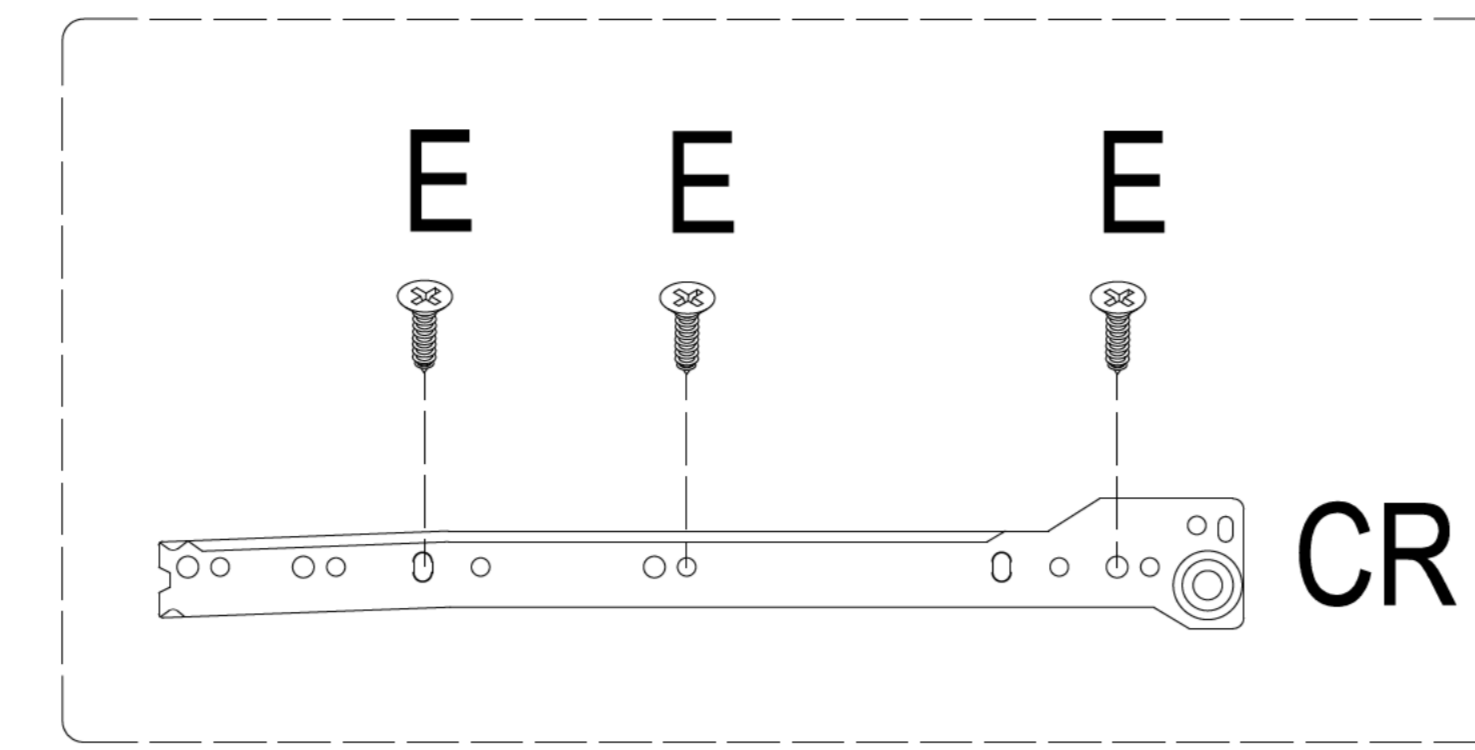

STEP 4

8 x1	10 x4	11 x1	A x1
B x9	D x4	M x9	

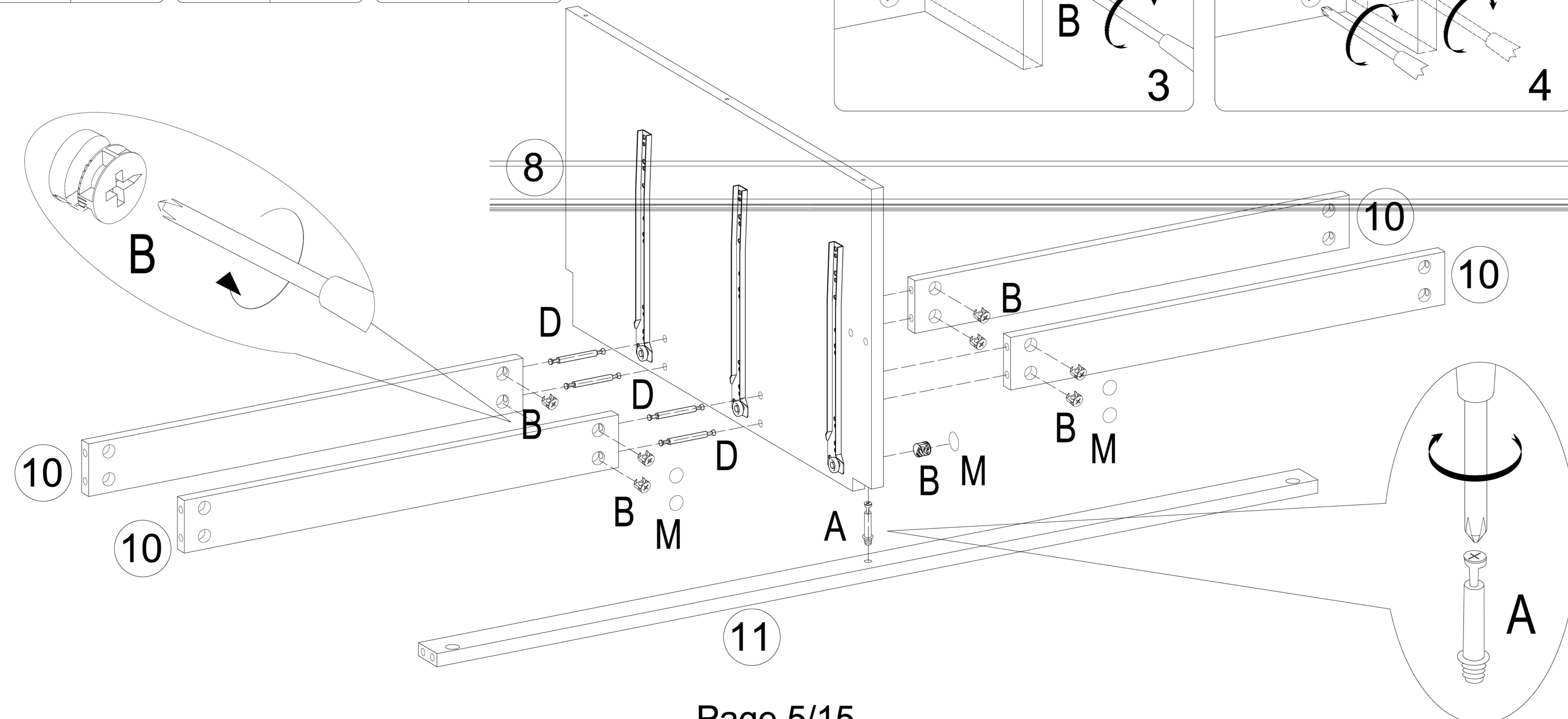
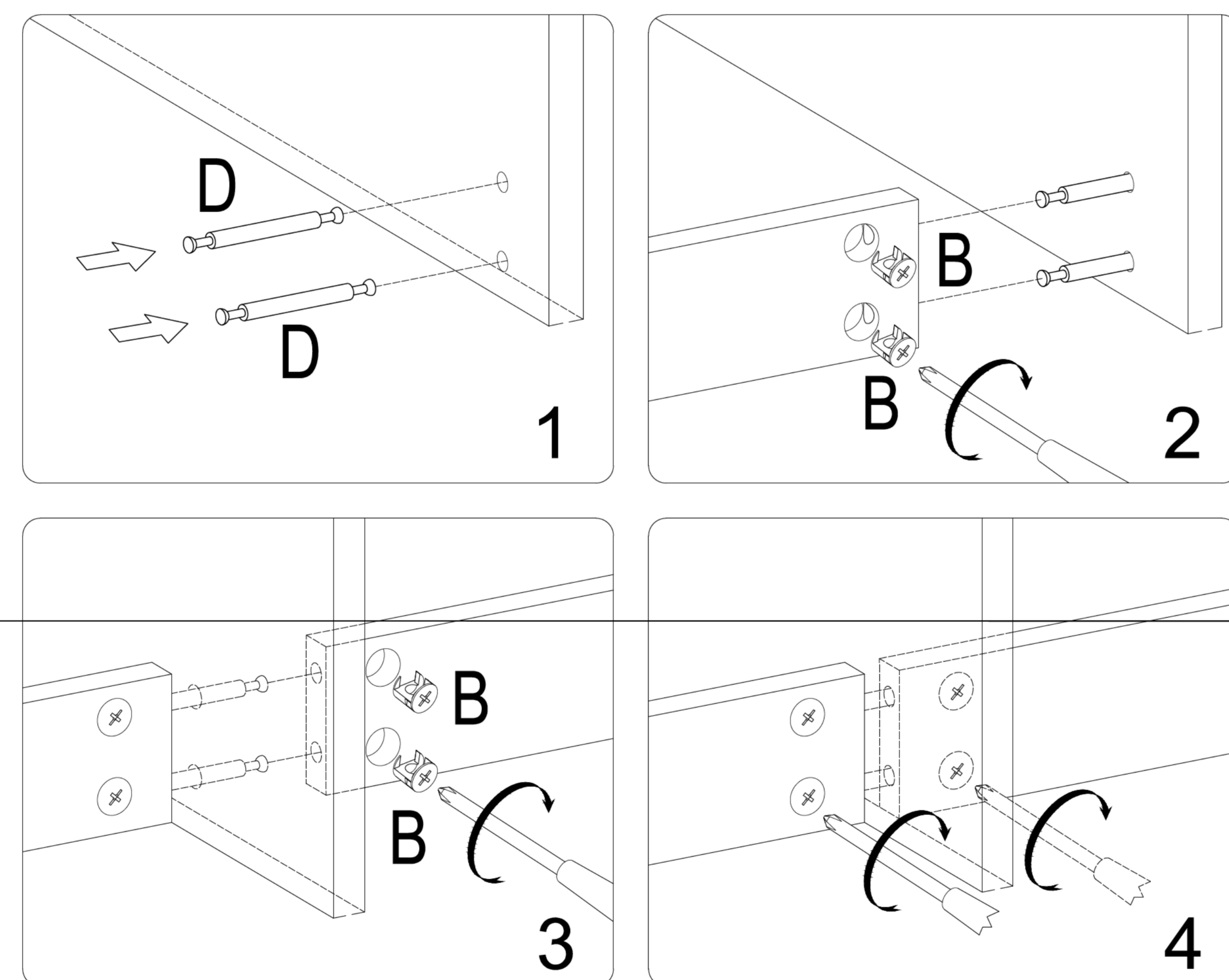

STEP 13

17 x6	18 x6	19 x6	F x24

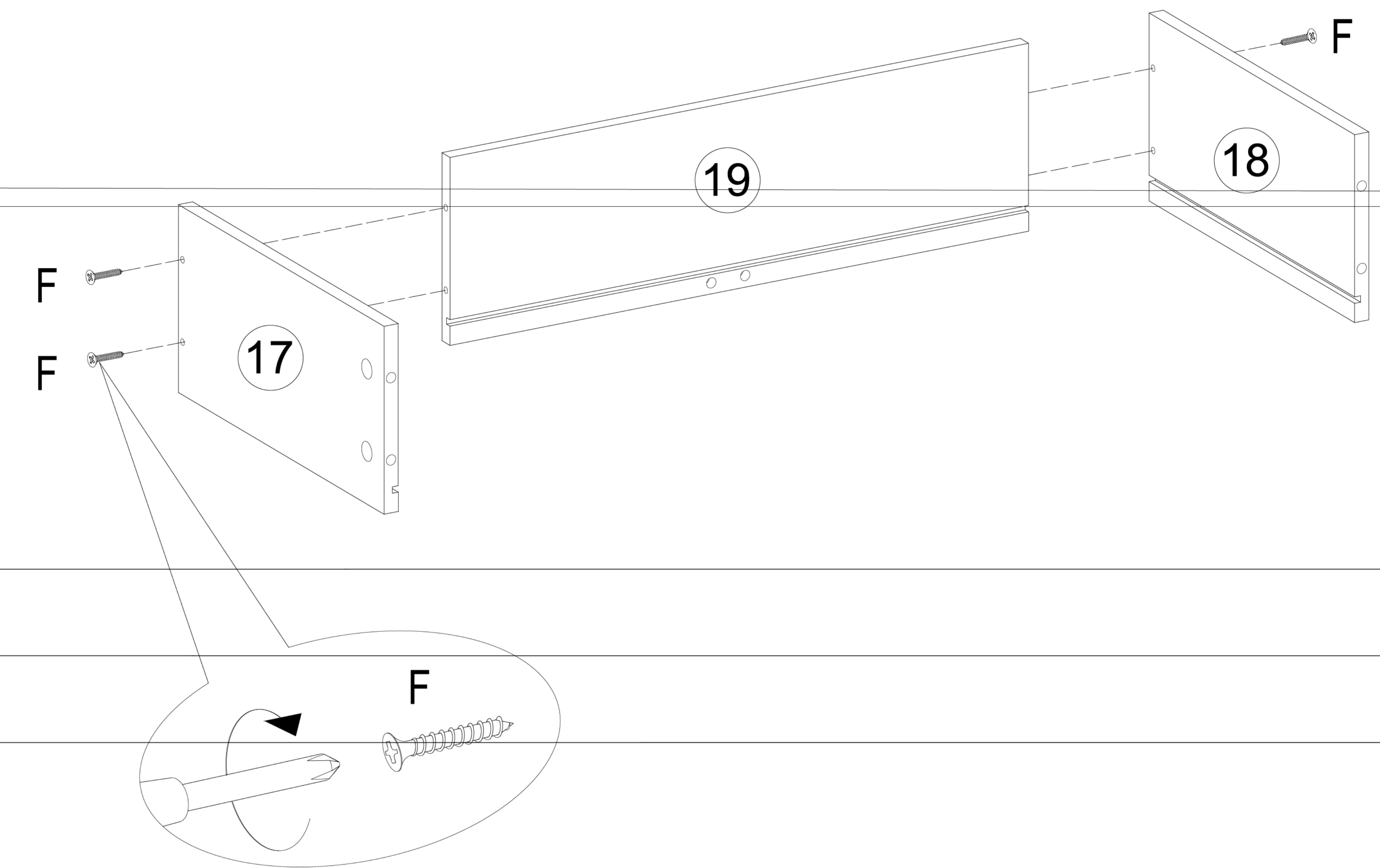

STEP 14

20 x6	A x12	B x12	M x12

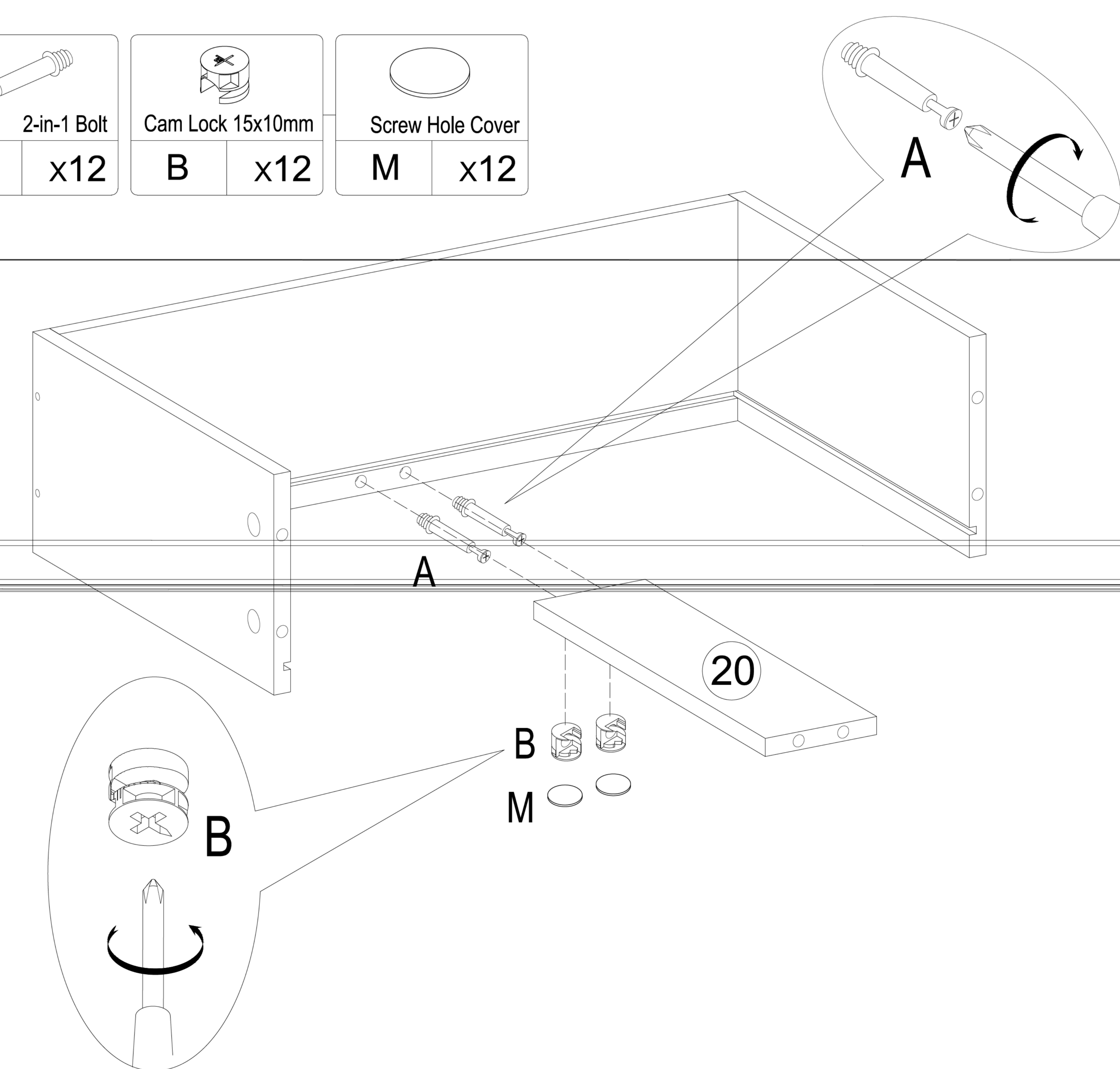

STEP 11

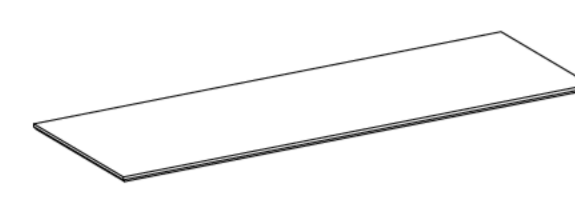
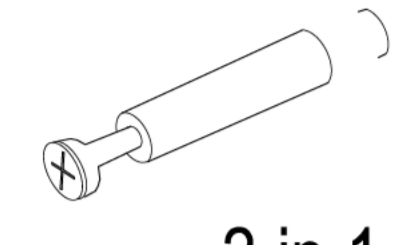
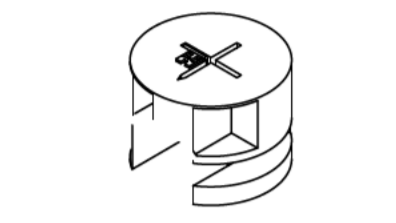
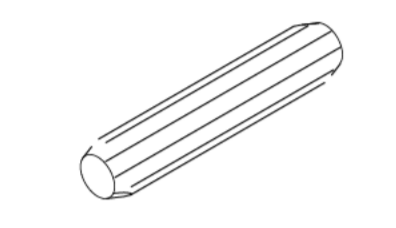
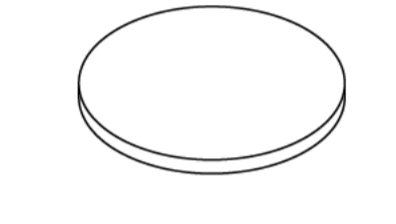
-  Front Panel
1 x1
-  2-in-1 Bolt
A x8
-  Cam Lock 15x10mm
B x8
-  Wooden Dowel
C x6
-  Screw Hole Cover
M x8

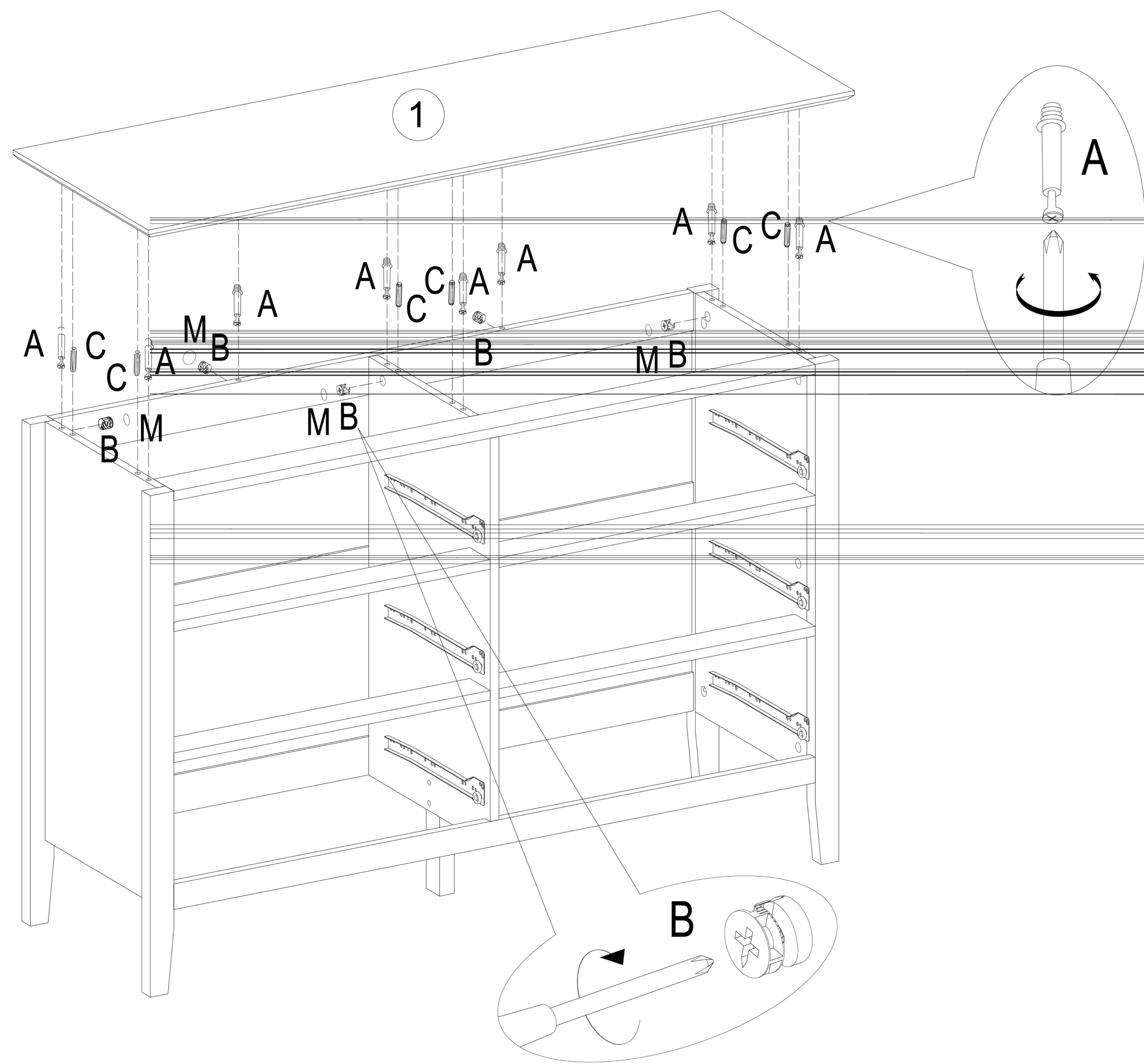

STEP 5

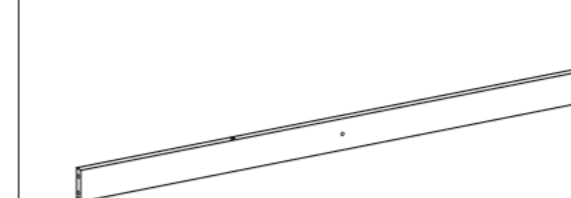
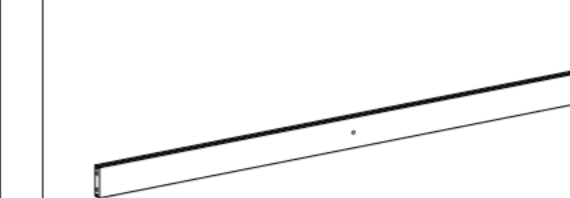
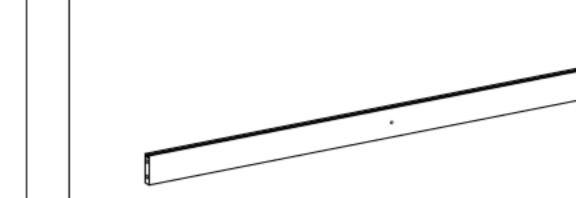
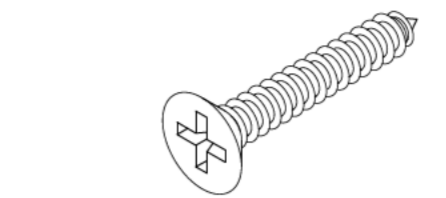
-  Upper Rear Support Bar
12 x1
-  Middle Rear Support Bar
13 x1
-  Lower Rear Support Bar
14 x1
-  Self-Tapping Screw 3.5x30mm
F x3

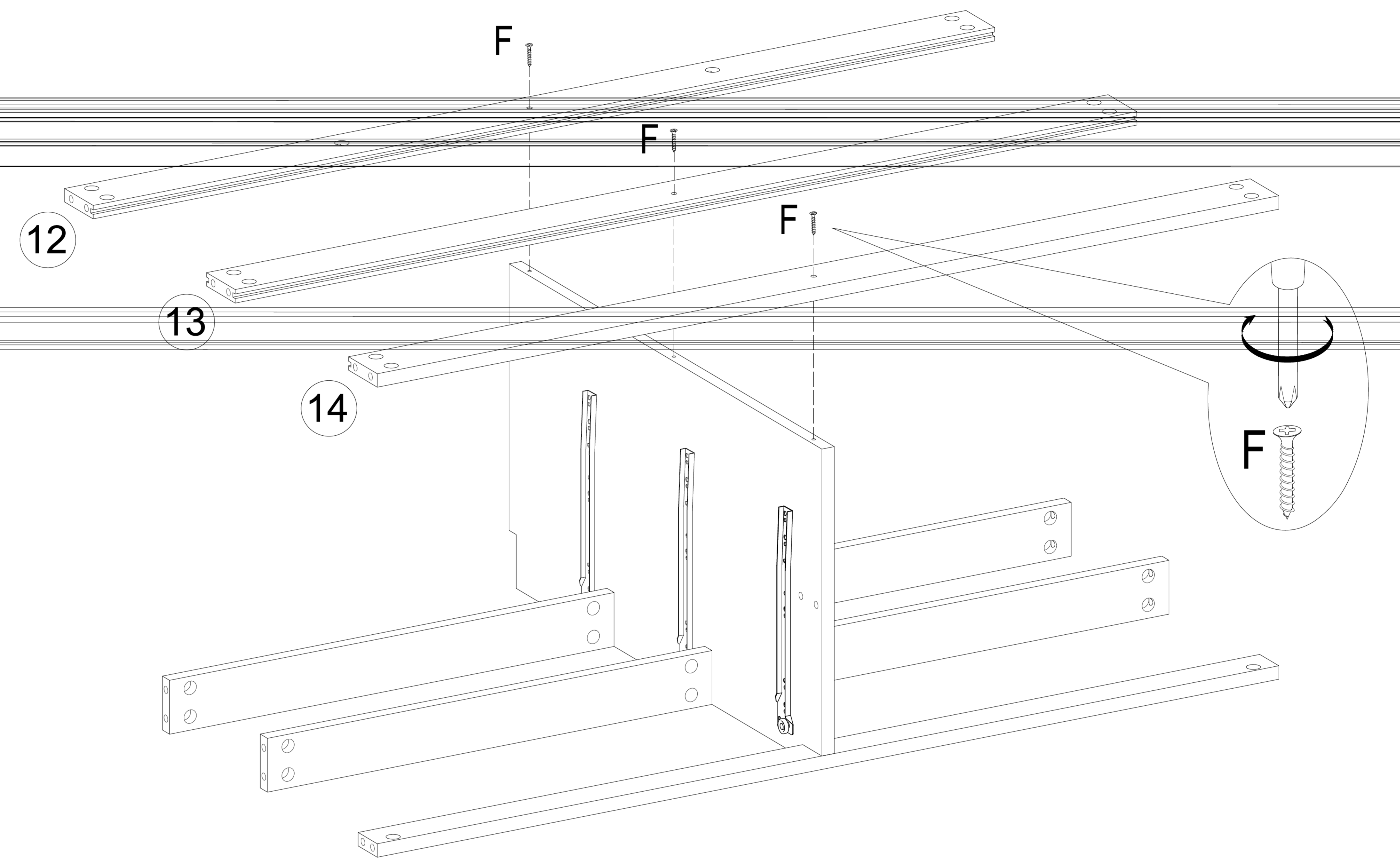

STEP 12

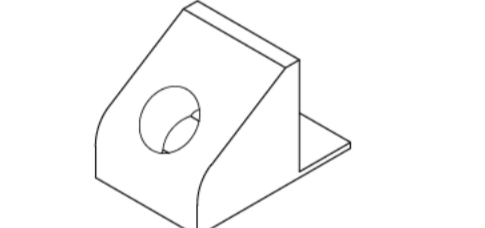
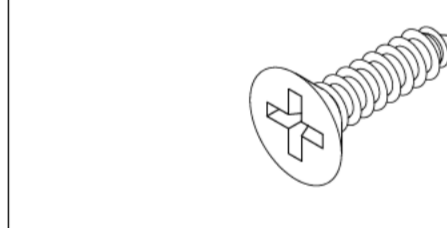
-  Back Panel Clamp
G x12
-  Self-Tapping Screw 3x16mm
H x12

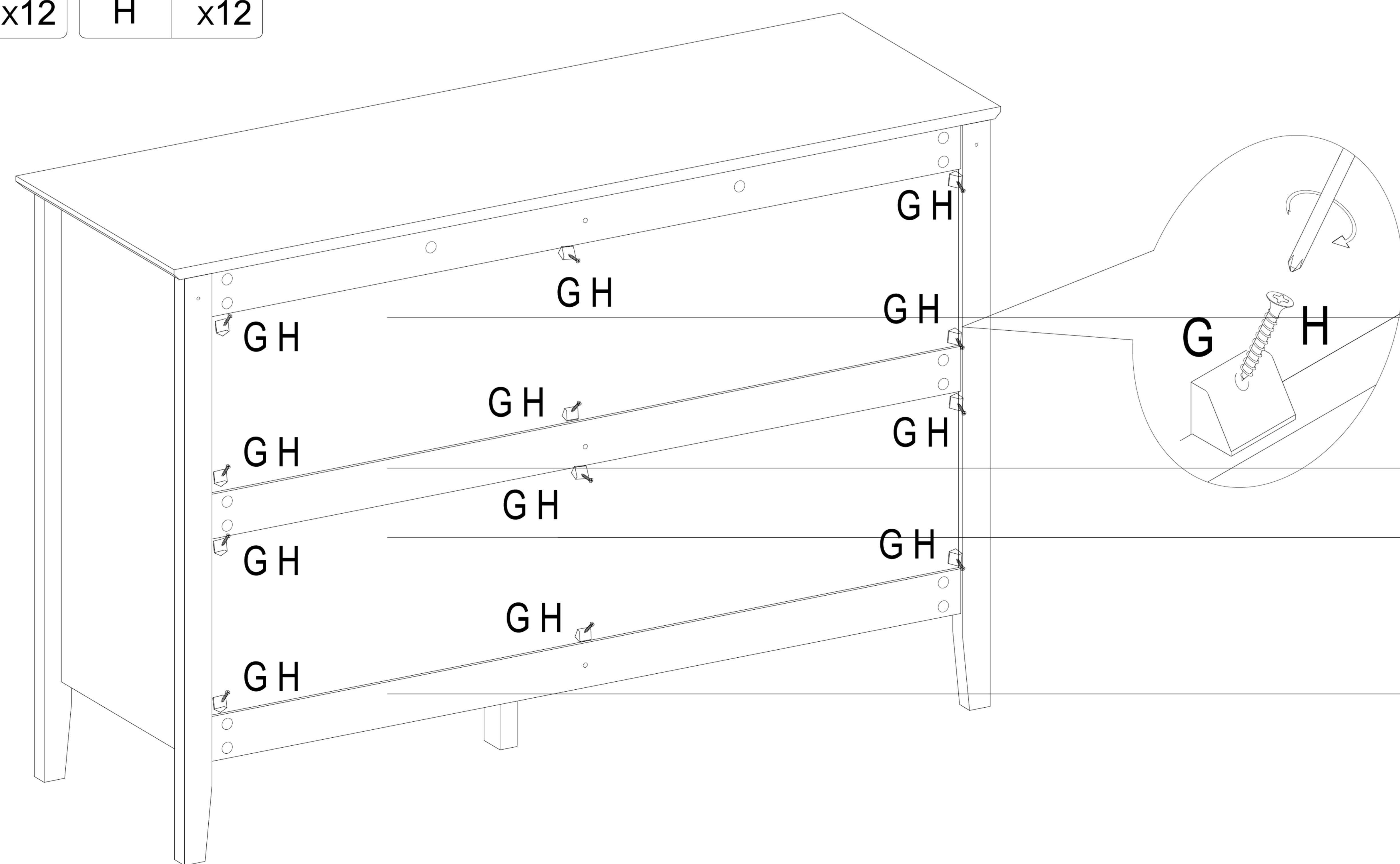

STEP 6

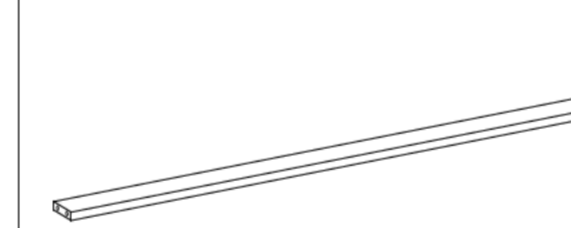
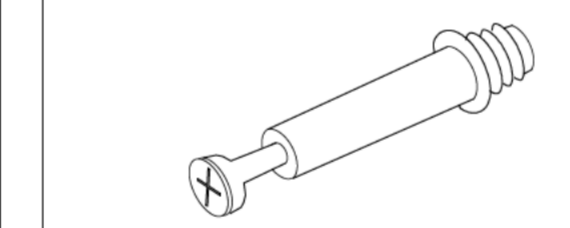
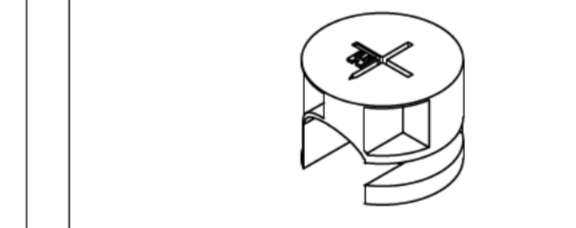
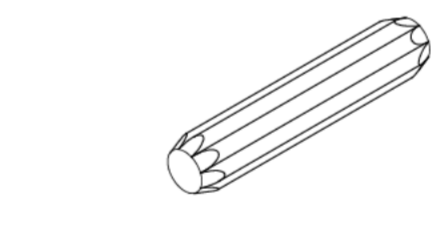
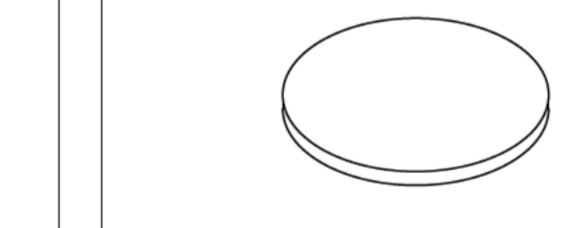
-  Front Upper Crossbar
9 x1
-  2-in-1 Bolt
A x13
-  Cam Lock 15x10mm
B x13
-  Wooden Dowel
C x1
-  Screw Hole Cover
M x13

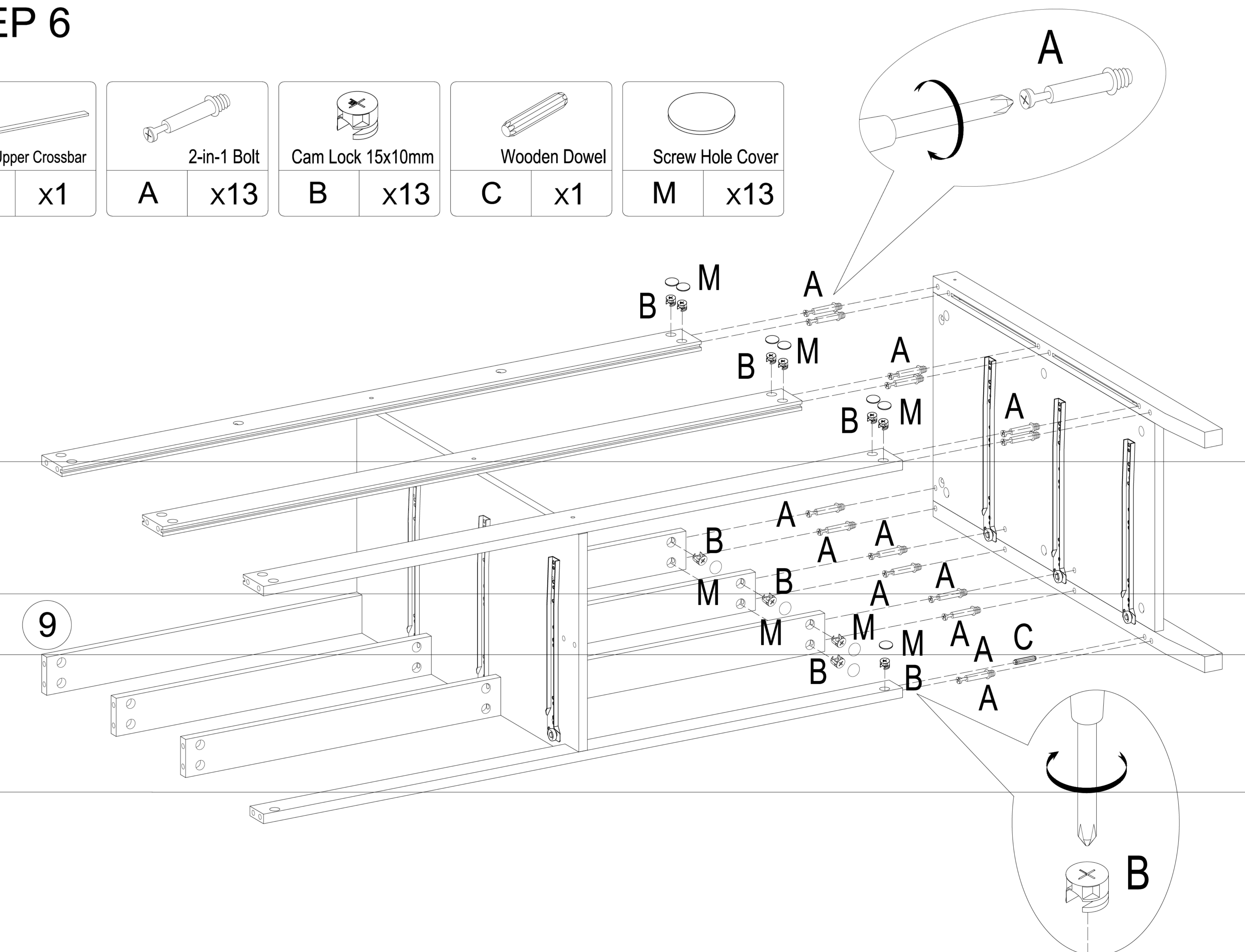

STEP 7

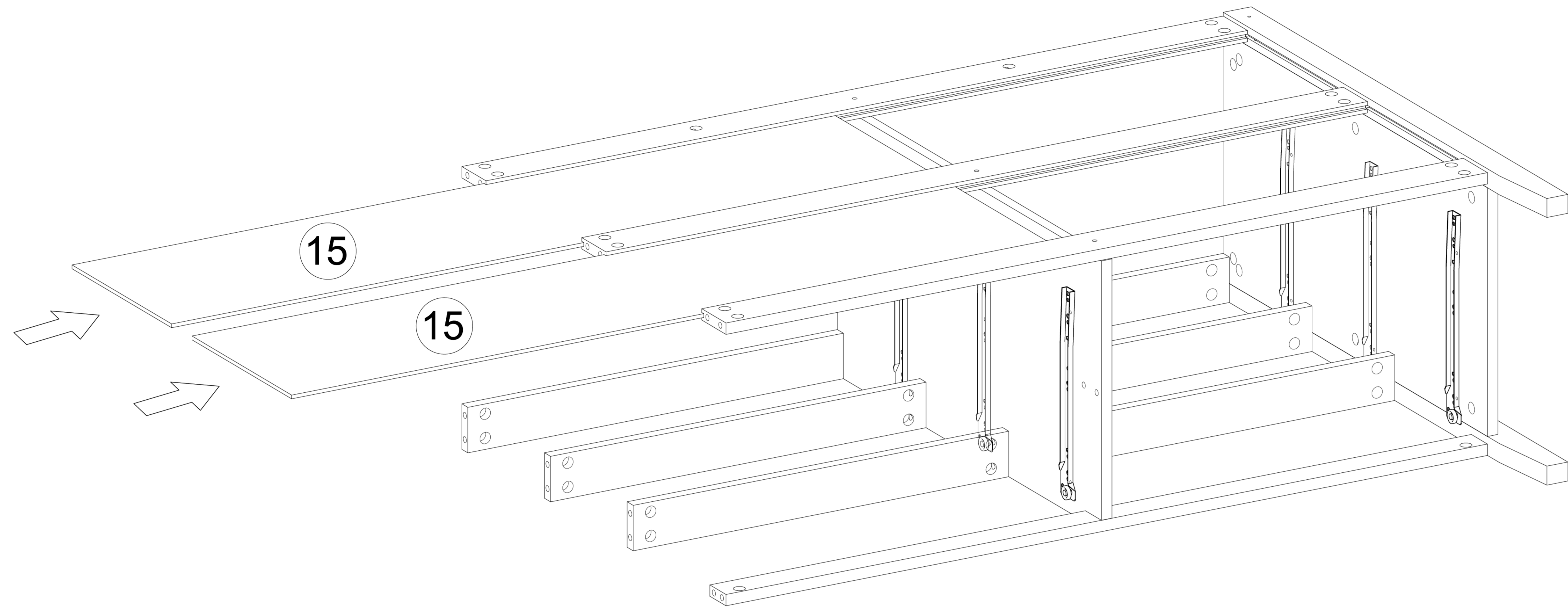
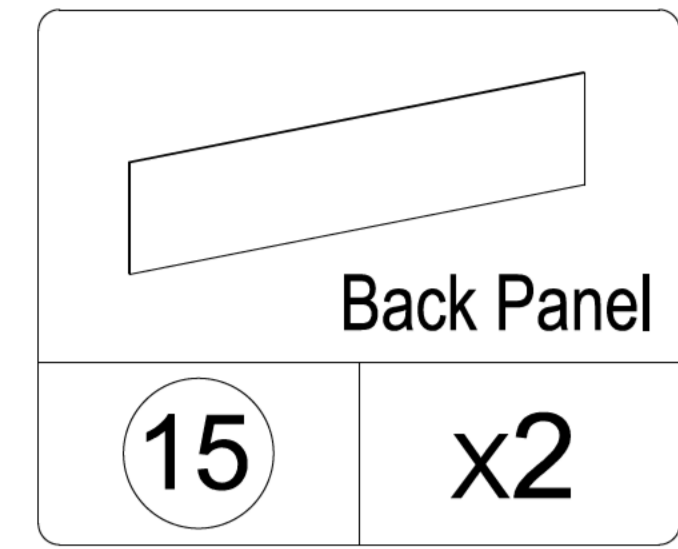

STEP 9

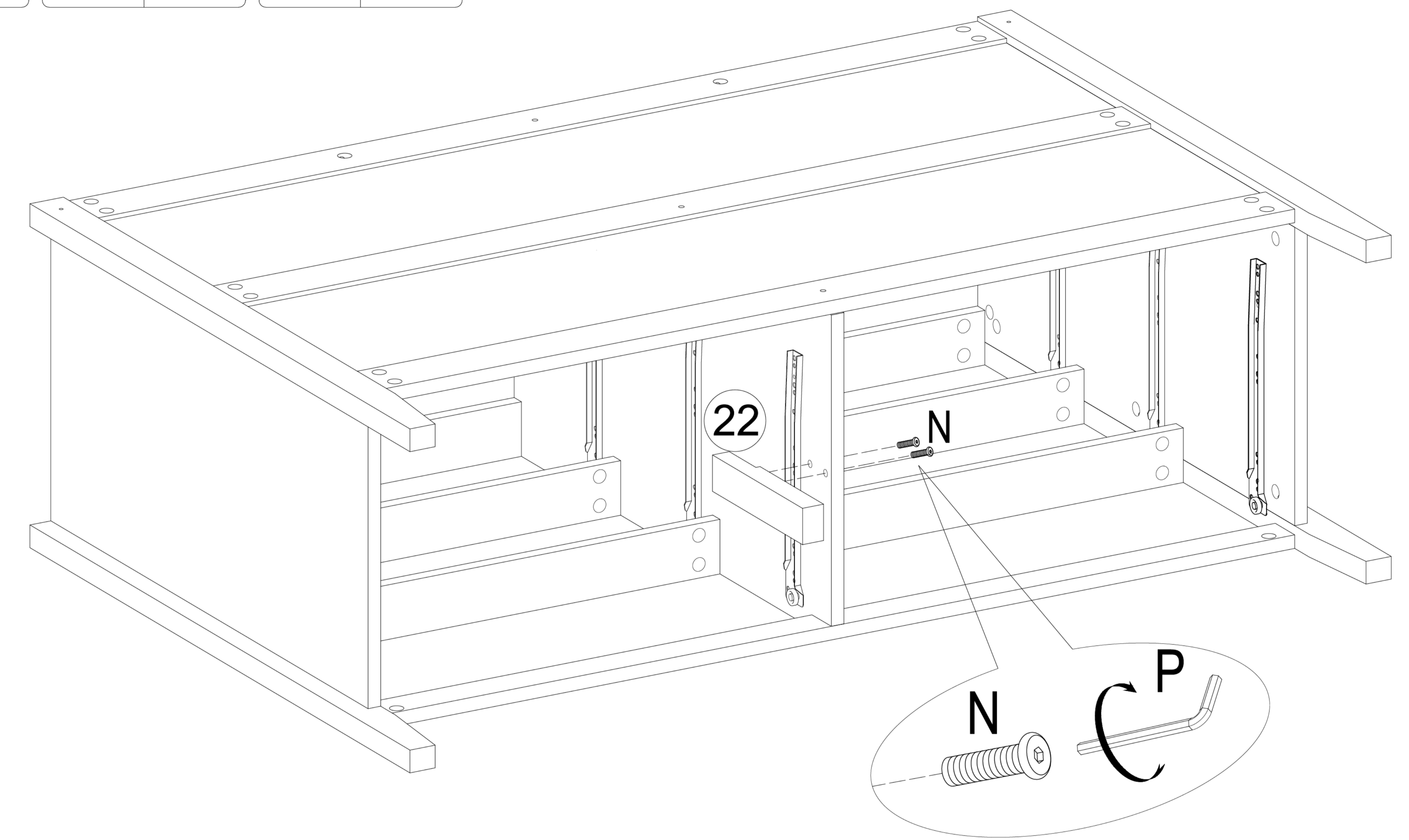
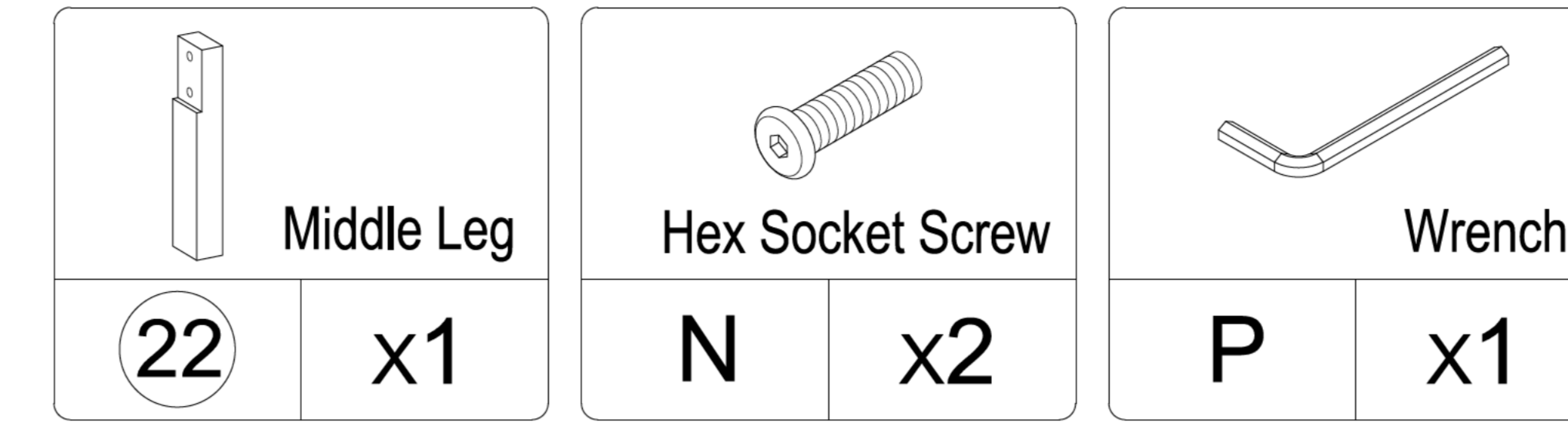

STEP 8

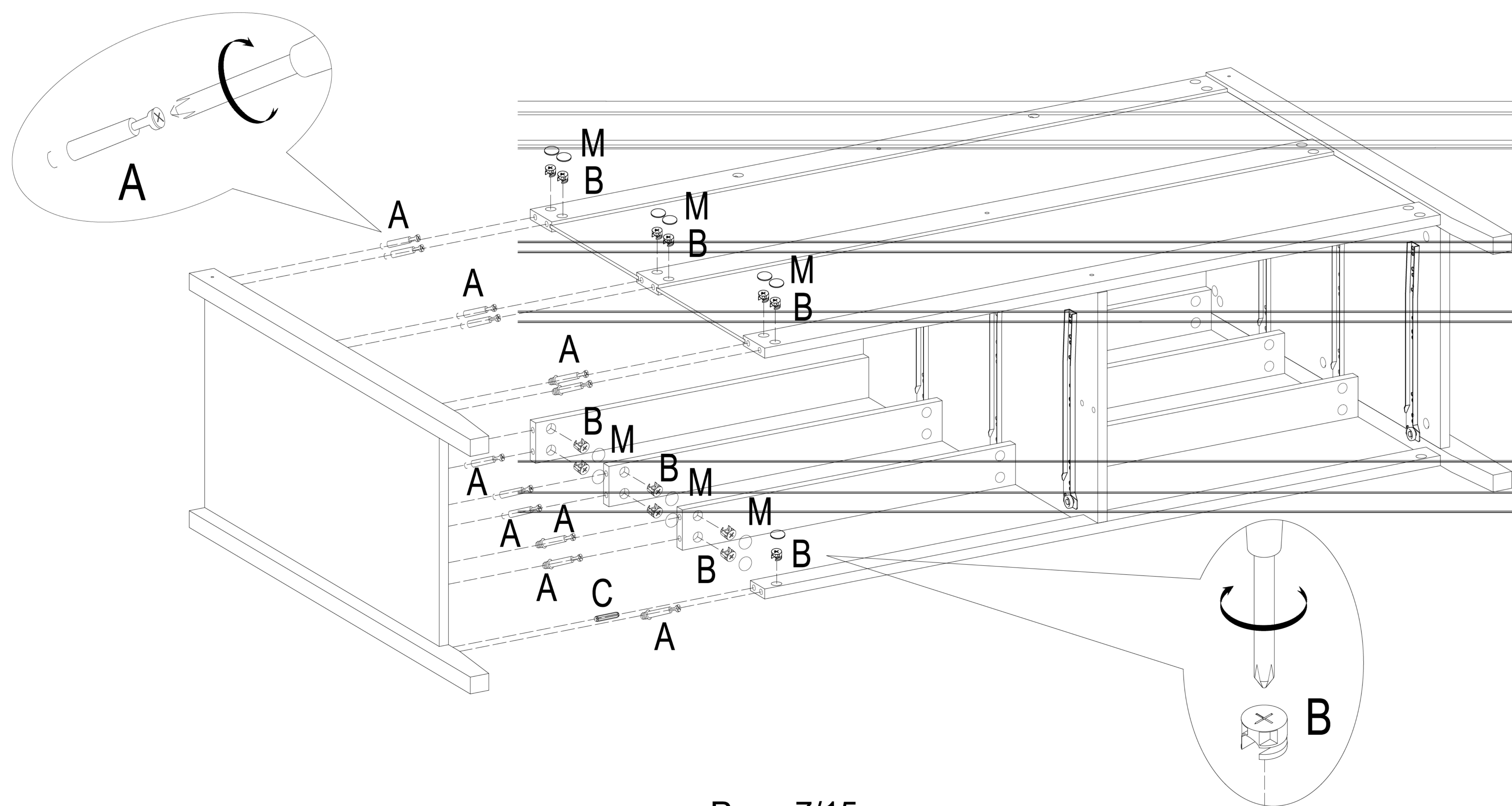
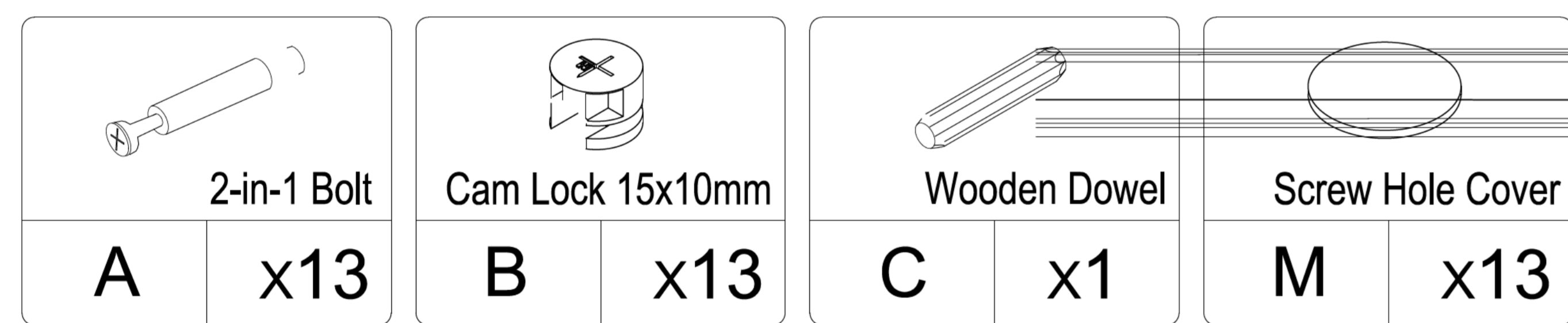

STEP 10

